

Material Handling Machines

LH 22 Industry

Litronic®

Generation

6

Operating Weight

42,300 – 48,900 lb*

Engine

141 HP (l) / 105 kW

Stage Tier 4f

* Without attachment



LIEBHERR

Performance

Power Plus Speed –
Redefined Performance

Economy

Good Investment –
Savings for Long-term

LH 22 M Industry Litronic

Operating Weight

42,300 – 48,300 lb*

Engine

141 HP (l)/105 kW

Stage Tier 4f

LH 22 C Industry Litronic

Operating Weight

46,300 – 48,900 lb*

Engine

141 HP (l)/105 kW

Stage Tier 4f

* Without attachment



Reliability

Durability and Sustainability –
Quality Down to the Last Detail

Comfort

Perfection at a Glance –
When Technology is Comfortable

Maintainability

Efficiency Bonus –
Even with Maintenance and Service



Performance



Power Plus Speed – Redefined Performance

Liebherr has been designing and manufacturing successful machines for material handling for over 50 years. With the different versions of the LH 22 Industry machine model of the new generation of Liebherr handlers, high performance and yet economical machines specially designed for use in waste and scrap recycling.

Maximum Handling Capacity

High Engine Performance

The optimized design of the 105 kW engine supplies a high torque output for fast and strong movements. Load peaks are cleverly compensated for to ensure that maximum torque is available at all times for highest handling capacity.

High Load Capacities

The intelligent arrangement of the components in the new uppercarriage concept optimizes the centre of gravity of the complete machine. This allows greater load capacities while retaining compact dimensions.

Captivating Dynamics

The combination of an increased engine output and a higher pump delivery volume guarantees maximum acceleration and speed of working motions.

Precision Operation

Intelligent Electronics

The elaborate machine controls guarantee that the hydraulics are optimally configured for the task at hand. Here, the load sensing control ensures that the flow delivered by the pump is optimally distributed when movements overlap. Speed and power are available whenever they are needed.

Sensitive Hydraulics

The optimal harmonisation between the engine and the control valve allows a fast and direct response from the hydraulics to the input command. This is controlled proportionally to enable smooth and gentle movements to be executed when the joystick is moved.

Firm and Stable Positioning

An essential prerequisite for precise working and maximum handling capacity is the firm and stable positioning of the machine. The design of the Liebherr undercarriage optimises the way forces are induced on components to minimize stress and guarantee maximum stability and durability.



Liebherr Diesel Engine Compliant with Tier 4f

- Powerful, robust and reliable
- Maximum torque even at low speeds to ensure fast movements with low fuel consumption
- Common-Rail injection system for maximum efficiency

Generator

- Twin-belt drive for good functional reliability
- High efficiency thanks to direct transmission of the engine torque
- Optimized belt guidance for long service life

Travel Motor

- Powerful, robust, reliable and quiet
- Better performance even on uphill grades due to electrical swivel angle adjustment for more torque, maximum acceleration and more driving power
- Fuel efficiency at maximum speed due to optimal adjustment of speed and delivery volume

Economy



Good Investment – Savings for the Long-term

Liebherr material handling machines combine high productivity with excellent economy – all as standard. Liebherr manages to achieve this difficult goal through sophisticated engine technology from its own production and improved demand-controlled hydraulics.

Fuel Efficiency

Requirement-controlled Cooling

The vanes of the fan are driven regardless of the diesel engine, generating the exact cooling output that is actually required. Thermal sensors guarantee reliable, need-based and efficient control.

Engine Idling and Engine Shut-down

The standard automatic idling function reduces the engine speed to idle as soon as the operator takes their hand from the joystick so that no hydraulic function is activated. Proximity sensors in the joystick levers restore the original engine speed as soon as the operator's hand is moved towards the lever again. This ensures that the set engine speed is available immediately. The result is a combination of fuel saving and reduced noise levels. Operating costs can be reduced even further with the optional automatic engine shut-down function.

Increased Productivity

Attachments and Quick Coupling Systems

Liebherr offers a wide selection of attachments for every application to increase the productivity of its material handling machines. In addition the material handlers can be fitted with a Liebherr quick coupling system which increases the productivity of the machine by up to 30%. The matching attachment and quick coupling system combined with the outstanding dynamics of a Liebherr handler ensures highest handling capacity and maximum productivity.

Road Licensing

The LH 22 M Industry with an adjustable boom package and the appropriate machine configuration can be issued with a road licence ex-works by the TÜV. This road licence enables it to work at the side of the road and to be driven to nearby places without the requirement for a special licence.

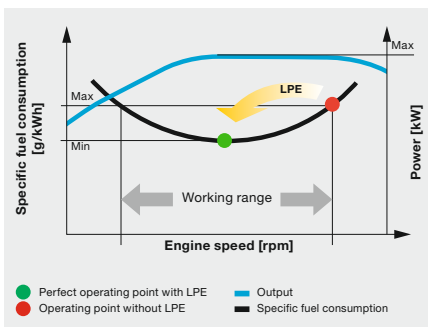

Low Fuel Consumption Thanks to Intelligent Machine Control

- Liebherr-Power Efficiency (LPE) optimizes the interaction of the drive components in terms of efficiency
- LPE enables machine operation in the area of the lowest specific fuel use for less consumption and greater efficiency with the same performance

Liebherr Attachments

- Robust and service-friendly slewing drive, can be turned 360°
- Optimum filling and clamping performance for effective material handling
- Finite element method (FEM) optimized for a perfect relationship between grapple weight, volume and a very long service life

Eco-Mode

- Reducing the engine speed by pressing a button
- Lower fuel consumption with unchanged high performance
- Economical and environmentally friendly working guaranteed
- Ideal for light to medium operations

Reliability



Durability and Sustainability – Quality Down to the Last Detail

Every day Liebherr material handlers show their qualities in a very wide range of industrial applications all over the world. Years of experience, continuous development and the latest technologies provide maximum safety in use. Their robust, compact design and the use of components produced in-house ensure that the material handling machine LH 22 is designed for a long service life.

More Safety

Pipe Fracture Safety Valves

The standard pipe fracture safety valves on the stick and hoist cylinders prevent the equipment from dropping in an unregulated way and ensure maximum safety during every operation.

Working Range Limiters

For operations in which the working range should be limited, the material handling machines can be specified with an optional working range limitation feature. Height, depth, width and proximity settings can be made to ensure that collisions and resulting component damage are avoided.

Overload Warning Device and Load Torque Limitation

The audible and visual overload warning system continuously tells the operator about the current load situation of the machine. Furthermore, load torque limitation automatically regulates the speed of the working hydraulics to allow the maximum load bearing capacity to be approached safely. In the event of an overload, the functions which could cause the machine to topple are disabled. Only movements back to the safe working range are then possible.



QPDM – Quality and Process Data Management

- QPDM allows production data to be logged, documented and evaluated
- Test specifications and machine documented automatically logged
- Ability to handle large quantities of data while maintaining uniform high quality

High Machine Availability

Quality and Competence

Our experience, understanding of customer needs and the technical implementation of these findings guarantee the success of the product. For decades, Liebherr has been inspirational with its depth of production and system solutions. Key components such as the diesel engine, electronic components, slew ring, swivel drive and hydraulic cylinders are developed and produced by Liebherr itself. The great extent of in-house manufacturing guarantees maximum quality and ensures that components are optimally configured to each other.

Robust Design

All steel components are designed and manufactured by Liebherr itself. High-strength steel plates configured for the toughest of requirements result in high torsional stiffness and optimum absorption of forces induced for a longer service life.

Intelligent Self Diagnostics

The innovative control electronics permanently monitor the vital functions of the machine to guarantee a high level of machine availability. Components which are critical for safety have a secondary redundancy feature to guarantee maximum safety and reliability.



Dust-intensive Jobs

- Large-dimension radiator with large mesh for optimum cooling performance, even in extremely dust-intensive conditions
- Protective grille with fine mesh, extending and folding fan for quick and easy cleaning
- Provision for the installation of filter systems on the cab



Recycling Package

- Reversible fan slows down the accumulation of dirt in the engine and radiator, guaranteeing high levels of machine availability
- Separate position of air conditioning compressor maximizes the air stream in the radiator / fan unit and guarantees good reliability even in extremely dust-intensive conditions
- Air pre-filter with dust discharge for extra-fine filtration of the engine intake air

Comfort



Perfection at a Glance – When Technology is Comfortable

The newly designed operator's work station sets new standards in comfort. The Liebherr deluxe cab is spacious, has an ergonomic design and is very quiet. This ensures that the operator remains intent and fully concentrated throughout the working day and enables him to deliver a constantly high performance.

Deluxe Cab

Ergonomic Design

The modern cab design provides excellent conditions for healthy, focussed and productive work in maximum comfort. The colour touchscreen display, the controls and operator's comfort seat are all coordinated to form a perfect ergonomic unit. In addition the ergonomic joysticks allow the machine operation to be both pleasant and precise.

Excellent All-round Vision

The large areas of glass, different versions of cab elevations and the rear and side area monitoring systems provide the operator with an excellent view of their working area and the zone around the machine. This perfect view enhances the operator's safety and ensures that they can handle the machine safely at all times.

Low Noise Levels

The use of viscoelastic mounts, good insulation and low-noise diesel engines from Liebherr minimizes noise emissions and vibrations. The noise levels are just 70 dB(A) in the operator's cab and 101 dB(A) outside. This means that the material handler LH 22 has low noise to preserve people and the environment.



Safe Access

- Foldable arm console for a safe and comfortable access
- Wide, non-slip steps and ergonomically positioned handles for an easy and safe access
- All access systems are designed to national guidelines and statutory regulations
- Elastic first step

Operator's Seat Comfort with Adjustable Armrests

- Greater seating comfort due to variable damper hardness, lockable horizontal suspension, pneumatic lumbar support, seat heating and passive seat air conditioning for concentrated working
- Individual adjustment options for armrests, seat cushion depth, seat angle and head restraint for comfortable working

Joystick with Proportional Control

- Good functionality with streamlined, ergonomic design
- 4-way mini joystick can be used to control all operations e.g. steering, outriggers and attachments etc.
- Joysticks – each with two newly designed buttons and a rocker switch – increase the number of functions available

Comfortable Operation

Proportional Control

Precision control of the material handling machine are especially important in applications such as waste separation or scrap recycling. Thanks to the standard proportional control, even such demanding operations can be mastered in style.

Joystick Steering and Stabilizing

The standard joystick steering gives the operator an additional comfort boost. The steering movement can be conveniently executed using the joystick, eliminating the need to reposition during the work cycle. Substituting the steering wheel in favour of joystick steering provides additional legroom and a clear view of the working area. A new standard feature is Joystick control of the outriggers for more convenience and an increased productivity.

Colour Touchscreen Display and Operation Unit

The 7" color touchscreen display is intuitive in its operation and provides continuous information about all important operating data. The shortcut keys can be individually assigned and are selected quickly and easily with the menu strip.

Maintainability



Efficiency Bonus – Even with Maintenance and Service

The Liebherr material handling machine LH 22 is powerful, robust, precise and efficient. It also features integral maintenance benefits as a result of their service-based machine design. The maintenance work for the Liebherr material handler can be carried out quickly, easily and safely. This minimizes the material handling machine's maintenance costs and down times.

Efficient Maintenance Concept

Service-based Machine Design

The service-based machine design guarantees short servicing times, thus minimizing maintenance costs due to the time it saves. All the maintenance points are easily accessible from the ground and easy to reach due to the large, wide-opening service doors. The enhanced service concept places the maintenance points close to each other and reduces their number to a minimum. This means that service work can be completed even more quickly and efficiently.

Integral Maintenance Benefits

Maintenance work helps to keep the machine fully functional. However this kind of work leads to machine downtimes which must be minimized. With change intervals of up to 500 hours for engine oil and up to 8,000 hours for hydraulic oil, Liebherr has significantly reduced the amount of maintenance and increased the productivity of the material handlers. In addition, central lubrication systems minimise daily maintenance.

Your Competent Service Partner

Remanufacturing

The Liebherr remanufacturing program offers cost-effective reconditioning of components to the highest quality standards. Various reconditioning levels are available: Replacement components, general overhaul or repair. The customer receives components with original part quality at a reduced cost.

Competent Advice and Service

Competent advice is a given at Liebherr. Experienced specialists provide decision guidance for your specific requirements: application-oriented sales support, service agreements, economical repair alternatives, original parts management, as well as remote data transmission for machine planning and fleet management.



Lubrication as it Works

- Fully automatic central lubrication system for uppercarriage and equipment
- Can be extended as an option to the connection link, quick coupler and attachment
- Fully automatic central lubrication system for the undercarriage available as an option
- Lubricates without interrupting work to ensure better productivity and a long component service life

Excellent Service Access

- Large, wide-opening service doors
- Engine oil, fuel, air and cab air filters are easily and safely accessible from the ground
- The oil level in the hydraulic tank can be checked from the cab
- Short service times for more productivity

Rapid Spare Parts Service

- 24-hour delivery: Spare parts service is available for our dealers around the clock
- Electronic spare parts catalogue: Fast and reliable selection and ordering via the Liebherr online portal
- With online tracking, the current processing status of your order can be viewed at any time

Material Handling Machines Overview

Equipment

- High load capacities and long reaches thanks to optimized kinematic properties and robust construction for greater handling performance
- Ingenious routing of hydraulic hoses optimizes the oil flow and minimizes power losses for maximum energy efficiency
- Pipe fracture safety valves on hoist and stick cylinders and retract stick shut-off for maximum safety during every application
- Quick coupling systems and attachments made by Liebherr for maximum machine capacity utilization and greater handling performance

Operator's Cab

- Joystick steering without steering column as standard for convenient operation, greater legroom and clear view of the working area
- Less strain on the operator, workers and reduced environmental pollution due to lower noise emissions
- Optimum visibility thanks to large glass surfaces and standard rear and side area monitoring with camera
- Proportional control as standard with 4-way mini joystick for greater precision, high precision control and functions





Uppercarriage

- Greater fuel efficiency thanks to the latest engine technology with intelligent machine control
- Recycling package for high levels of machine availability even in extremely dust-intensive conditions
- New uppercarriage concept for greater load capacities and optimum service access
- Optimized hydraulics for greater fuel efficiency and faster work cycles

Undercarriage

- Maximum acceleration and higher drawbar pull thanks to a new travel motor for greater travelling performance
- Load-holding valves fitted as standard on all support cylinders for maximum stability in every application
- Fewer downtimes thanks to maintenance-free support cylinders
- Undercarriage variants with dozer blade for universal operation of the material handling machine

The Perfect Solution for Every Application

Attachments

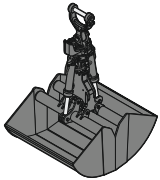

Grab for loose material

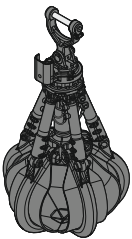

Multi-tine grab

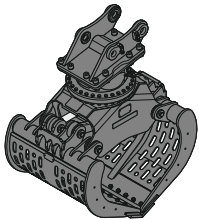

Sorting grab

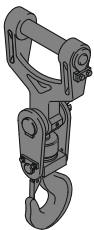

Load hook

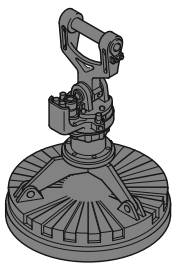

Magnet devices

Sticks

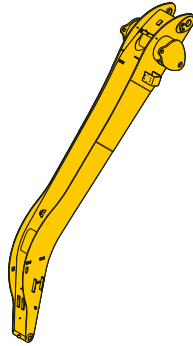

Angled stick

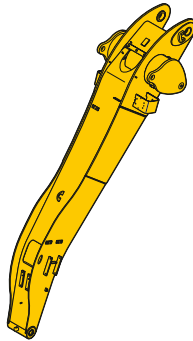

Flat angled stick

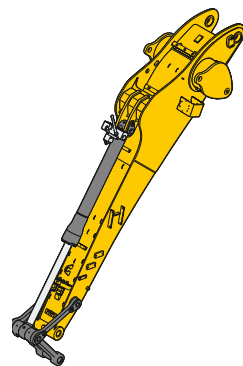

Stick with tipping kinematics

Booms

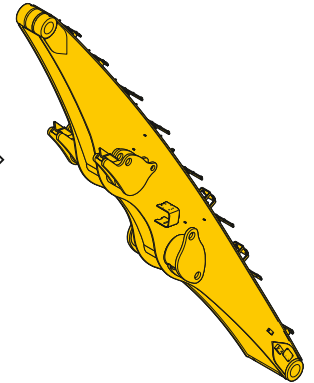

Straight boom

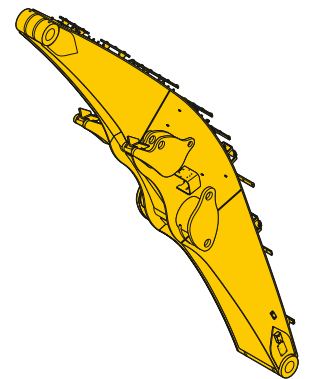

Angled boom

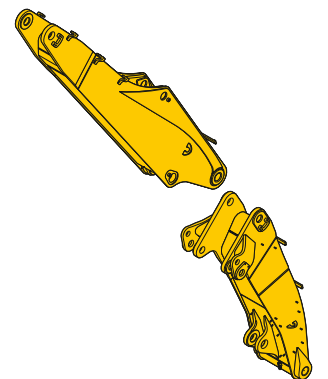

Two-piece boom

Cab Elevations

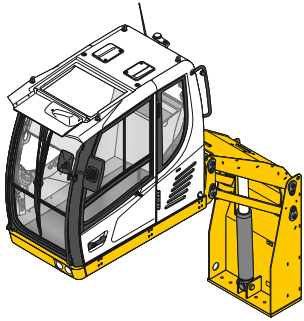

Hydraulic cab elevation



30° tilt function

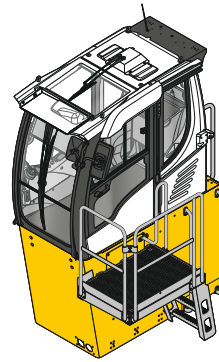

Rigid cab elevation

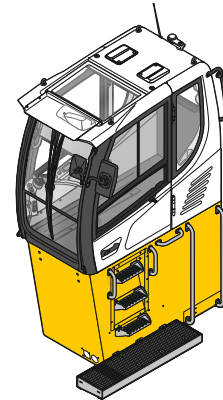

Uppercarriage

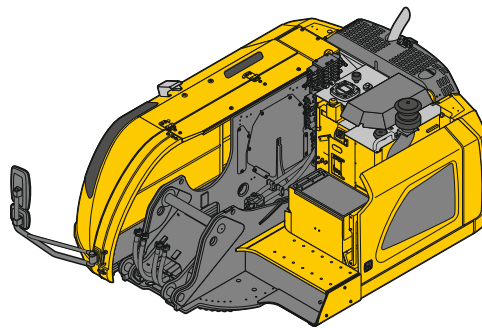

Undercarriage

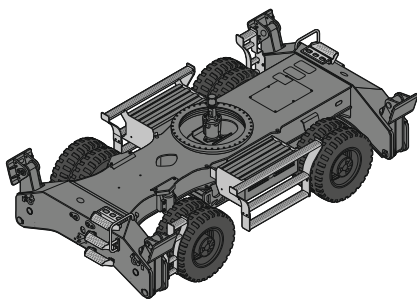

Mobile, 4 point outriggers

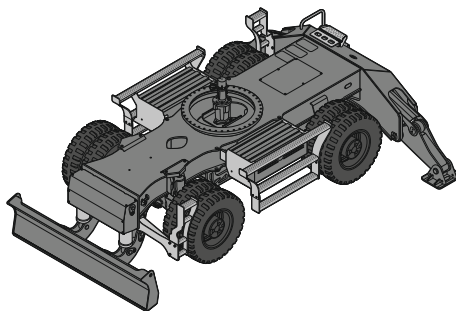

Mobile, blade + 2 point outriggers

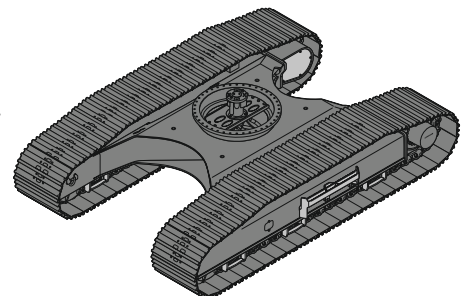

Crawler

Experience the Progress

The invention of the mobile tower crane in 1949 also marked the birth of the Liebherr company. During its first decade the small construction company developed into an established manufacturer of construction machines and other technically advanced products. The R 353 and its first industrial equipment were launched in 1951 to lay the foundations for the production of today's material handling machines. The A 911

mobile material handling machine a few years later enabled the company to make the breakthrough into material handling. Over the years the machines have been developed continually and today they are designed uncompromisingly for the industrial use.

1949

First tower crane TK10



1968

Breakthrough with the A 911 mobile material handler



1974

Silenced material handling machine



R 353 with the first industrial equipment

1961



Production plant in Kirchdorf

1970



First hydraulic cab elevation

1983

Liebherr has now been developing and manufacturing material handling machines for a very wide range of applications in the scrap, port and timber handling sectors and for the waste and recycling industry for over 50 years. In the development of its machines, Liebherr chooses quality, durability and reliability from the very outset, together with performance and economy. Years of experience in design and construction are not only

reflected in the end product but also in the components which are developed, designed and manufactured by Liebherr itself. This multiple sector expertise is used in product design from the early phase of the development process and thus allows high level technical innovations to be made.

2007

Opening of the assembly building for material handling machines



2013

Launch of the new LH series



2016

Launch of the new Port Material Handling Machines



Awarded the Bauma Design Prize for the LH 120

2010



Awarded the Bauma Innovation Prize for the ERC cylinder



Awarded the IF Award for the material handling machine LH 60

2014

Technical Data



Diesel Engine

Rating per SAE J1349/ISO 9249	141 HP (l) (105 kW) at 1,800 rpm
Model	D924 – FPT motor designed for Liebherr
Type	4 cylinder in-line
Bore/Stroke	4.1/5.2 in
Displacement	274.61 in ³
Engine operation	4-stroke diesel Common-Rail turbo-charged and after-cooled reduced emissions
Air cleaner	dry-type air cleaner with pre-cleaner, primary and safety elements
Engine idling	sensor controlled
Electrical system	
Voltage	24 V
Batteries	2 x 135 Ah/ 12 V
Alternator	three-phase current 28 V/ 140 A
Stage Tier 4f	
Harmful emissions values	in accordance with EPA/CARB-40CFR stage Tier 4f
Emission control	Liebherr-SCR technology
Fuel tank	98 gal
Urea tank	12 gal



Cooling System

Diesel engine	water-cooled compact cooling system consisting cooling unit for water, hydraulic oil and charge air with stepless thermostatically controlled fan, fans for radiator cleaning can be completely folded away
----------------------	--



Hydraulic Controls

Power distribution	via control valves with integrated safety valves, simultaneous and independent actuation of chassis, swing drive and equipment
Servo circuit	
Equipment and swing	with hydraulic pilot control and proportional joystick levers
Chassis	
Mobile	electro-proportional via foot pedal
Crawler	with hydraulic proportionally functioning foot pedals or adjusted with plugable levers
Additional functions	via switch or electro-proportional foot pedals
Proportional control	proportionally acting transmitters on the joysticks for additional hydraulic functions



Hydraulic System

Hydraulic pump	Liebherr axial piston variable displacement pump
for equipment and travel drive	
Max. flow	79 gpm
Max. pressure	5,076 psi
Hydraulic pump regulation and control	Liebherr-Synchron-Comfort-system (LSC) with electronic engine speed sensing regulation, pressure and flow compensation, torque controlled swing drive priority
Hydraulic tank	41 gal
Hydraulic system	93 gal
Hydraulic oil filter	1 main return filter with integrated partial micro filtration (5 µm)
MODE selection	adjustment of engine and hydraulic performance via a mode pre-selector to match application, e.g. for especially economical and environmentally friendly operation or for maximum material handling and heavy-duty jobs
S (Sensitive)	mode for precision work and lifting through very sensitive movements
E (Eco)	mode for especially economical and environmentally friendly operation
P (Power)	mode for high performance with low fuel consumption
P+ (Power-Plus)	mode for highest performance and for very heavy duty applications, suitable for continuous operation
Engine speed and performance setting	stepless alignment of engine output and hydraulic power via engine speed
Option	Tool Control: 20 pre-adjustable pump flows and pressures for add-on attachments



Swing Drive

Drive	Liebherr axial piston motor with integrated brake valve and torque control
Swing ring	Liebherr, sealed race ball bearing swing ring, internal teeth
Swing speed	0 – 9,0 rpm stepless
Swing torque	39,091 lbf ft
Holding brake	wet multi-disc (spring applied, pressure released)
Option	slewing gear brake Comfort



Operator's Cab

Cab	TOPS safety cab structure (tip-over protection) with individual windscreens or featuring a slide-in subpart under the ceiling, work headlights integrated in the ceiling, a door with a sliding window (can be opened on both sides), large stowing and depositing possibilities, shock-absorbing suspension, sound damping insulating, tinted laminated safety glass, separate shades for the sunroof window and windscreen
Operator's seat Comfort	air cushioned operator's seat with 3D-adjustable armrests, headrest, lap belt, seat heater, adjustable seat cushion inclination and length, lockable horizontal suspension, automatic weight adjustment, adjustable suspension stiffness, pneumatic lumbar vertebrae support and passive seat climatization with active coal
Operator's seat Premium (Option)	in addition to operator's seat comfort: active electronic weight adjustment (automatic re-adjustment), pneumatic low frequency suspension and active seat climatization with active coal and ventilator
Control system	joysticks with control consoles and swivel seat, folding left control console
Operation and displays	large high-resolution operating unit, self-explanatory, color display with touchscreen, video-compatible, numerous settings, control and monitoring options, e.g. air conditioning control, fuel consumption, machine and attachment parameters
Air-conditioning	automatic air-conditioning, recirculated air function, fast de-icing and demisting at the press of a button, air vents can be operated via a menu; recirculated air and fresh air filters can be easily replaced and are accessible from the outside; heating-cooling unit, designed for extreme outside temperatures, sensors for solar radiation, inside and outside temperatures



Equipment

Type	high-strength steel plates at highly-stressed points for the toughest requirements. Complex and stable mountings of equipment and cylinders
Hydraulic cylinders	Liebherr cylinders with special sealing and guide system and, depending on cylinder type, shock absorption
Bearings	sealed, low maintenance



Undercarriage

Mobile	
Drive	oversized two speed power shift transmission with additional creeper speed, Liebherr axial piston motor with functional brake valve on both sides
Travel speed	
Joystick steering	0 – 2.2 mph stepless (creeper speed + transmission stage 1) 0 – 4.3 mph stepless (transmission stage 1) 0 – 7.5 mph stepless (creeper speed + transmission stage 2) 0 – 7.5 mph stepless (transmission stage 2)
Wheel steering (Option)	0 – 2.2 mph stepless (creeper speed + transmission stage 1) 0 – 4.3 mph stepless (transmission stage 1) 0 – 8.1 mph stepless (creeper speed + transmission stage 2) 0 – 12.4 mph stepless (transmission stage 2)
Driving operation	automotive driving using accelerator pedal, cruise control function: storage of variable accelerator pedal positions
Axles	70,548 lb drive axles; manual or automatic hydraulically controlled front axle oscillation lock
Service brake	two circuit travel brake system with accumulator; wet and backlash-free disc brake
Holding brake	wet multi-disc (spring applied, pressure released)
Stabilization	stabilizing blade + 2 point outriggers 4 point outriggers
Option	dozer blade, at the front, for 4 point outriggers
Crawler	
Version	LC
Drive	Liebherr compact planetary reduction gear with Liebherr axial piston motor per side of undercarriage
Travel speed	0 – 1.7 mph stepless (creeper speed) 0 – 2.9 mph stepless
Brake	functional brake valves on both sides
Holding brake	wet multi-disc (spring applied, pressure released)
Track pads	triple grouser



Complete Machine

Lubrication	Liebherr central lubrication system for upper-carriage and equipment, automatically
Mobile (Option)	Liebherr central lubrication system for undercarriage, automatically
Steps system	safe and durable access system with anti-slip steps; main components hot-galvanized
Noise emission	
ISO 6396	L _{pA} (inside cab) = 70 dB(A)
2000/14/EC	L _{WA} (surround noise) = 101 dB(A)

LH 22 M – Dimensions

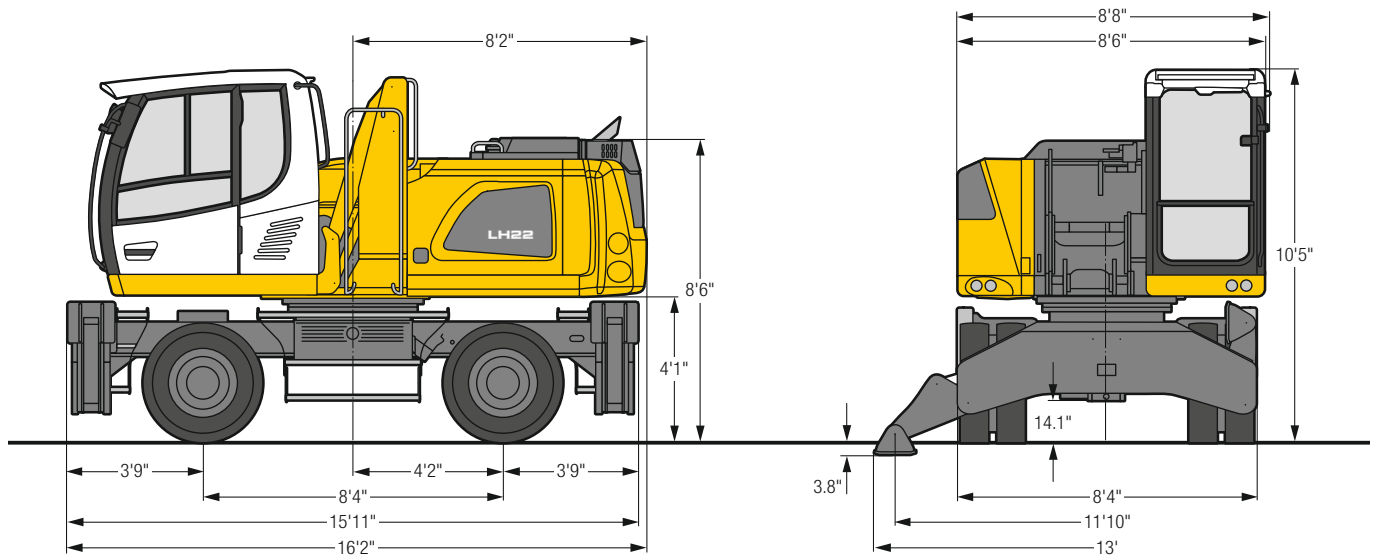

LH 22 M – Choice of Cab Elevation

Cab Elevation LFC (Rigid Elevation)

Cab Elevation LHC (Hydraulic Elevation)

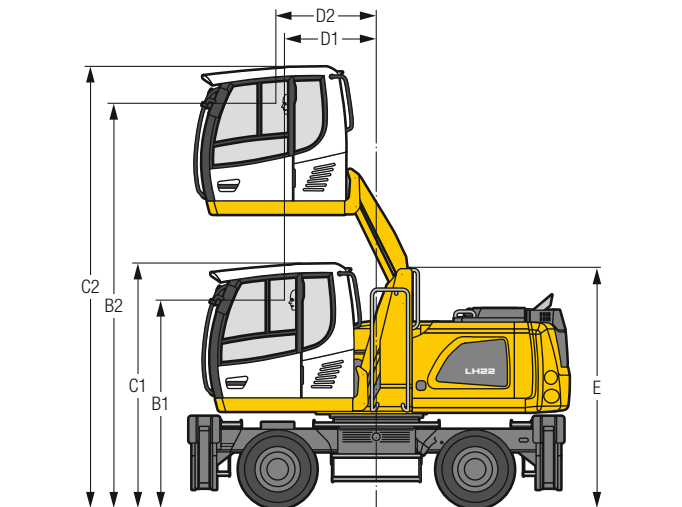
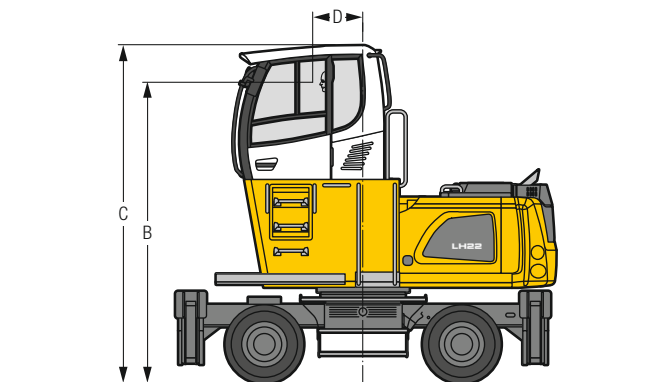

Increase type	LFC 120
Height	3'11"
B	12' 9"
C	14' 4"
D	2' 2"

A rigid cab elevation has a fixed eye level height. For a lower transport height, the shell of the cab can be removed and replaced by a transport device. The dimension C is in this machine design for all rigid cab elevations 11'4".

Increase type	LHC 255
B1	8'10"
B2	17' 2"
C1	10' 5"
C2	18' 9"
D1	3'11"
D2	4' 3"
E	10' 2"

The hydraulically adjustable cab allows the driver, that he can choose his field of view freely and at any time within the stroke.

Tires 10.00-20

LH 22 C – Dimensions

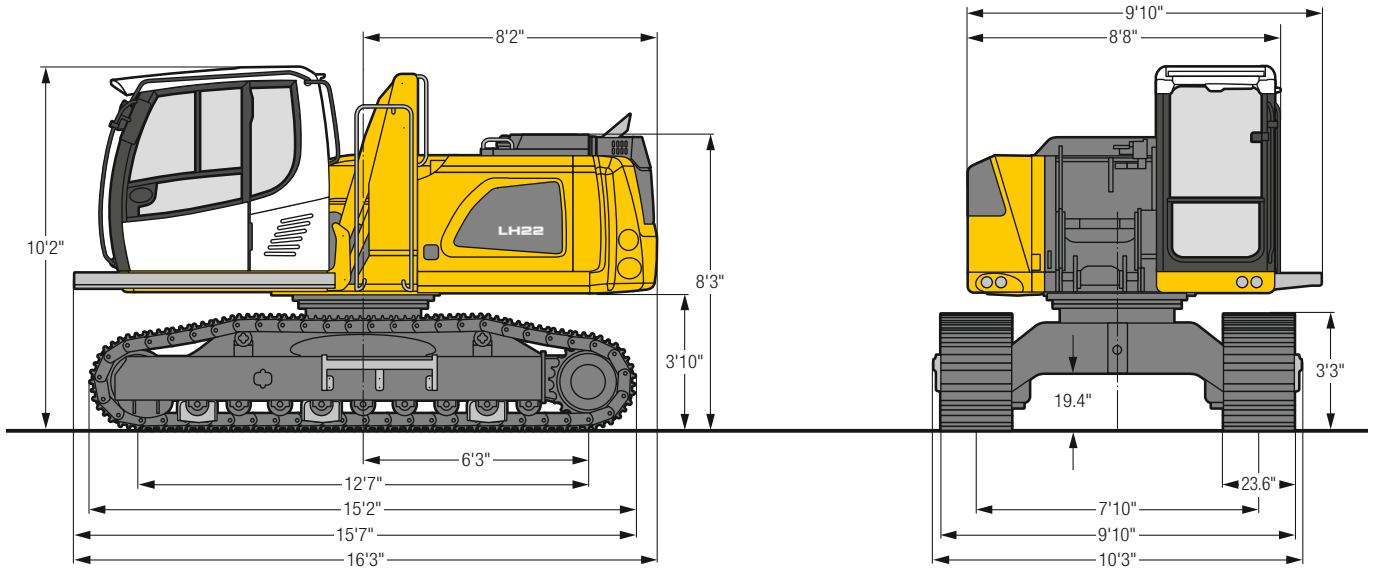

LH 22 C – Choice of Cab Elevation

Cab Elevation LFC (Rigid Elevation)

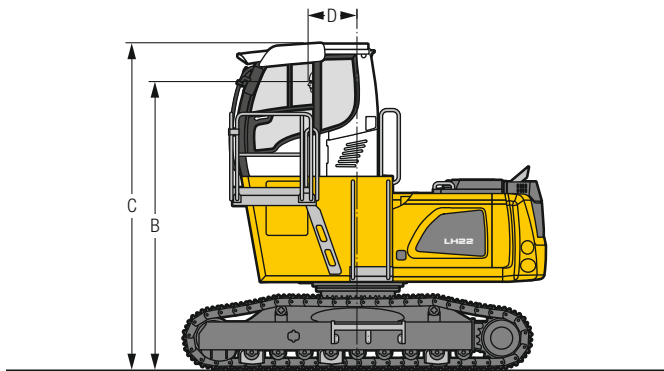

Increase type	LFC 120
Height	3' 11"
B	12' 6"
C	14' 2"
D	2' 2"

A rigid cab elevation has a fixed eye level height. For a lower transport height, the shell of the cab can be removed and replaced by a transport device. The dimension C is in this machine design for all rigid cab elevations 11'3".

Cab Elevation LHC (Hydraulic Elevation)

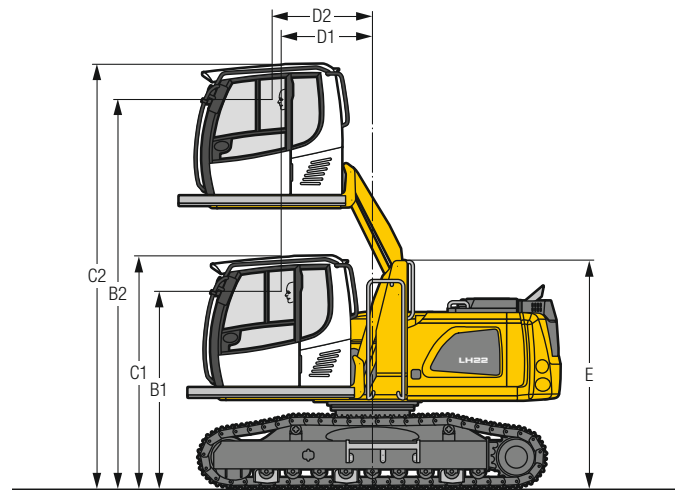

Increase type	LHC 255
B1	8' 7"
B2	16' 11"
C1	10' 2"
C2	18' 6"
D1	4'
D2	4' 4"
E	9' 11"

The hydraulically adjustable cab allows the driver, that he can choose his field of view freely and at any time within the stroke.

LH 22 M – Equipment GA10

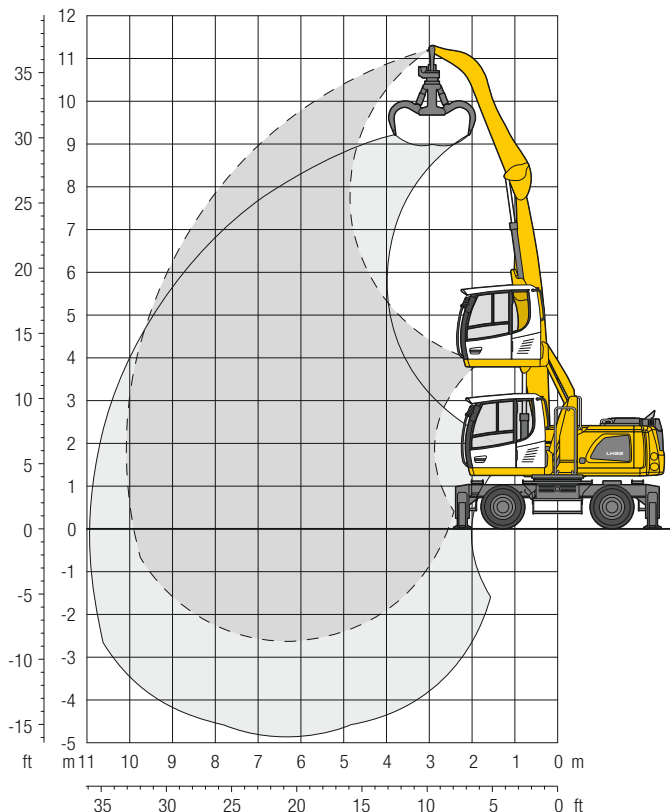

Operating Weight

The operating weight includes the basic machine with 4 point outriggers, hydr. cab elevation, 8 solid tires plus intermediate rings, straight boom 19'8", angled stick 13'1" and multi-tine grab GM 55B/0.52 yd³ semi-closed tines.

Weight 49,600 lb

Dimensions

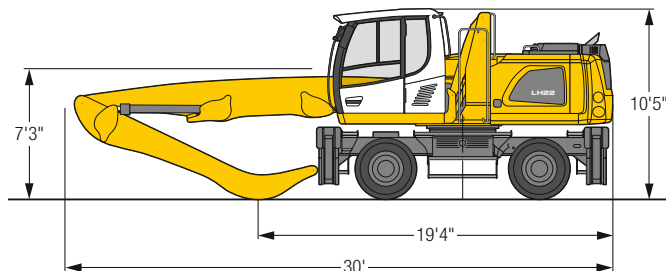

ft	Undercarriage	10 ft		15 ft		20 ft		25 ft		30 ft		ft in		
35	Stabilizers raised											11,5*	11,5*	14' 8"
	4 pt. outriggers down											11,5*	11,5*	
30	Stabilizers raised					8,3	10,9					6,8	8,8*	22' 4"
	4 pt. outriggers down					11,8*	11,8*					8,8*	8,8*	
25	Stabilizers raised					8,4	11,1	5,8	7,7			5,1	6,8	26'11"
	4 pt. outriggers down					12,5*	12,5*	10,8*	10,8*			7,9*	7,9*	
20	Stabilizers raised			12,9	15,5*	8,3	10,9	5,8	7,7			4,2	5,7	29'11"
	4 pt. outriggers down			15,5*	15,5*	12,7*	12,7*	10,7*	10,7*			7,4*	7,4*	
15	Stabilizers raised			12,2	16,4	7,9	10,5	5,6	7,5	4,2	5,6	3,7	5,1	31'10"
	4 pt. outriggers down			16,9*	16,9*	13,3*	13,3*	10,9*	10,9*	8,6	9,0*	7,3*	7,3*	
10	Stabilizers raised	19,8	29,0	11,1	15,2	7,4	10,0	5,3	7,2	4,0	5,5	3,5	4,8	32'10"
	4 pt. outriggers down	29,1*	29,1*	18,6*	18,6*	13,9*	13,9*	11,0*	11,0*	8,5	8,9*	7,4*	7,4*	
5	Stabilizers raised	2,6*	2,6*	10,0	14,1	6,9	9,5	5,1	6,9	3,9	5,4	3,4	4,7	33'
	4 pt. outriggers down	2,6*	2,6*	19,3*	19,3*	14,0*	14,0*	10,8*	10,8*	8,4	8,4*	6,6*	6,6*	
0	Stabilizers raised	3,9*	3,9*	9,4	13,4	6,5	9,1	4,9	6,7	3,8	5,3	3,5	4,8	32' 6"
	4 pt. outriggers down	3,9*	3,9*	16,5*	16,5*	13,2*	13,2*	10,0*	10,0*	7,4*	7,4*	5,6*	5,6*	
-5	Stabilizers raised			9,2	13,2	6,3	8,9	4,8	6,6			3,9	5,3	29' 8"
	4 pt. outriggers down			14,2*	14,2*	11,0*	11,0*	8,3*	8,3*			5,6*	5,6*	
-10	Stabilizers raised													
	4 pt. outriggers down													

Height Can be slewed through 360° In longitudinal position of undercarriage Max. reach * Limited by hydr. capacity

The lift capacities on the stick end without attachment are stated in lb x 1,000 and are valid on a firm, level supporting surface with blocked oscillating axle. These capacities can be slewed through 360° with the undercarriage in the transverse position. Capacities in the longitudinal position of the undercarriage (+/- 15°) are specified over the steering axle with the stabilizers raised and over the rigid axle with the stabilizers down. Indicated loads based on the ISO 10567 standard and do not exceed 75% of tipping or 87% of hydraulic capacity. The lift capacity of the unit is limited by its stability, the lifting capability of the hydraulic elements, or the maximum permissible lifting capacity of the load hook.

LH 22 M – Equipment GA11

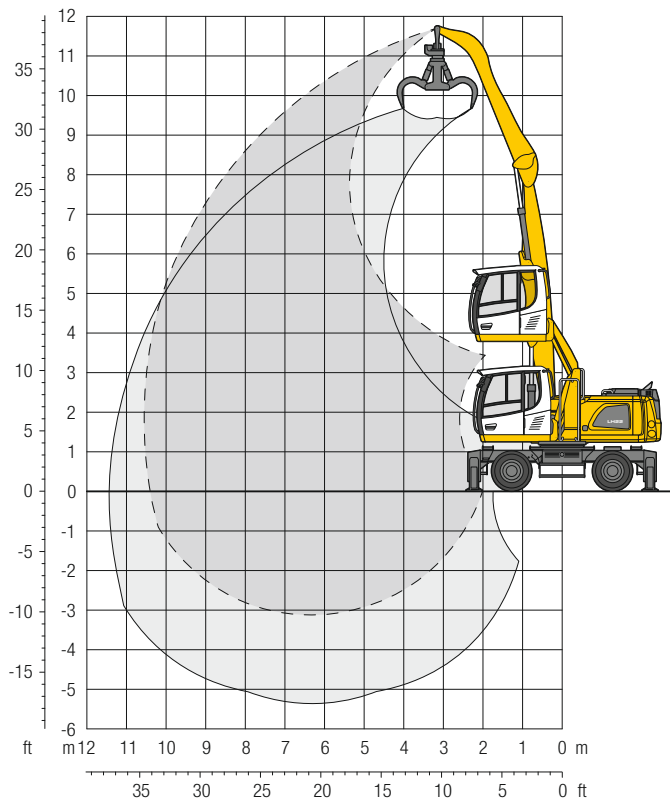

Operating Weight

The operating weight includes the basic machine with 4 point outriggers, hydr. cab elevation, 8 solid tires plus intermediate rings, straight boom 19'8", angled stick 14'9" and multi-tine grab GM 55B/0.52 yd³ semi-closed tines.

Weight 49,800 lb

Dimensions

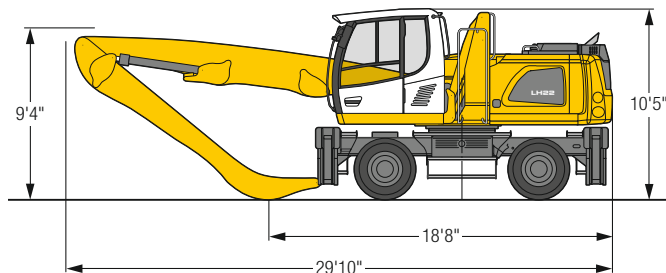

ft	Undercarriage	10 ft		15 ft		20 ft		25 ft		30 ft		ft in		
35	Stabilizers raised			12,2*	12,2*							9,3*	9,3*	18' 2"
	4 pt. outriggers down			12,2*	12,2*							9,3*	9,3*	
30	Stabilizers raised					8,5	11,2					5,9	7,6*	24' 8"
	4 pt. outriggers down					11,7*	11,7*					7,6*	7,6*	
25	Stabilizers raised					8,6	11,3	5,9	7,9			4,5	6,1	28'10"
	4 pt. outriggers down					12,0*	12,0*	10,4*	10,4*			6,9*	6,9*	
20	Stabilizers raised					8,5	11,1	5,9	7,8	4,3	5,8	3,9	5,2	31' 8"
	4 pt. outriggers down					12,2*	12,2*	10,4*	10,4*	8,8	9,0*	6,5*	6,5*	
15	Stabilizers raised			12,5	16,0*	8,1	10,7	5,7	7,6	4,2	5,7	3,5	4,7	33' 6"
	4 pt. outriggers down			16,0*	16,0*	12,8*	12,8*	10,7*	10,7*	8,7	9,0*	6,4*	6,4*	
10	Stabilizers raised	20,9	27,4*	11,4	15,6	7,5	10,2	5,4	7,3	4,1	5,6	3,2	4,5	34' 5"
	4 pt. outriggers down	27,4*	27,4*	18,0*	18,0*	13,6*	13,6*	10,9*	10,9*	8,6	8,9*	6,5*	6,5*	
5	Stabilizers raised	5,4*	5,4*	10,3	14,3	7,0	9,6	5,1	7,0	3,9	5,4	3,2	4,4	34' 8"
	4 pt. outriggers down	5,4*	5,4*	19,2*	19,2*	14,0*	14,0*	10,9*	10,9*	8,4	8,6*	6,3*	6,3*	
0	Stabilizers raised	5,0*	5,0*	9,5	13,5	6,5	9,1	4,9	6,7	3,8	5,3	3,2	4,4	34' 1"
	4 pt. outriggers down	5,0*	5,0*	18,4*	18,4*	13,5*	13,5*	10,3*	10,3*	7,9*	7,9*	5,4*	5,4*	
-5	Stabilizers raised	7,2*	7,2*	9,1	13,1	6,3	8,8	4,7	6,6	3,8	5,2	3,5	4,8	32'
	4 pt. outriggers down	7,2*	7,2*	15,5*	15,5*	11,8*	11,8*	9,0*	9,0*	6,3*	6,3*	5,1*	5,1*	
-10	Stabilizers raised					6,3	8,7*					5,2	7,2	23' 2"
	4 pt. outriggers down					8,7*	8,7*					7,2*	7,2*	

Height Can be slewed through 360° In longitudinal position of undercarriage Max. reach * Limited by hydr. capacity

The lift capacities on the stick end without attachment are stated in lb x 1,000 and are valid on a firm, level supporting surface with blocked oscillating axle. These capacities can be slewed through 360° with the undercarriage in the transverse position. Capacities in the longitudinal position of the undercarriage (+/- 15°) are specified over the steering axle with the stabilizers raised and over the rigid axle with the stabilizers down. Indicated loads based on the ISO 10567 standard and do not exceed 75% of tipping or 87% of hydraulic capacity. The lift capacity of the unit is limited by its stability, the lifting capability of the hydraulic elements, or the maximum permissible lifting capacity of the load hook.

LH 22 M – Equipment GK9

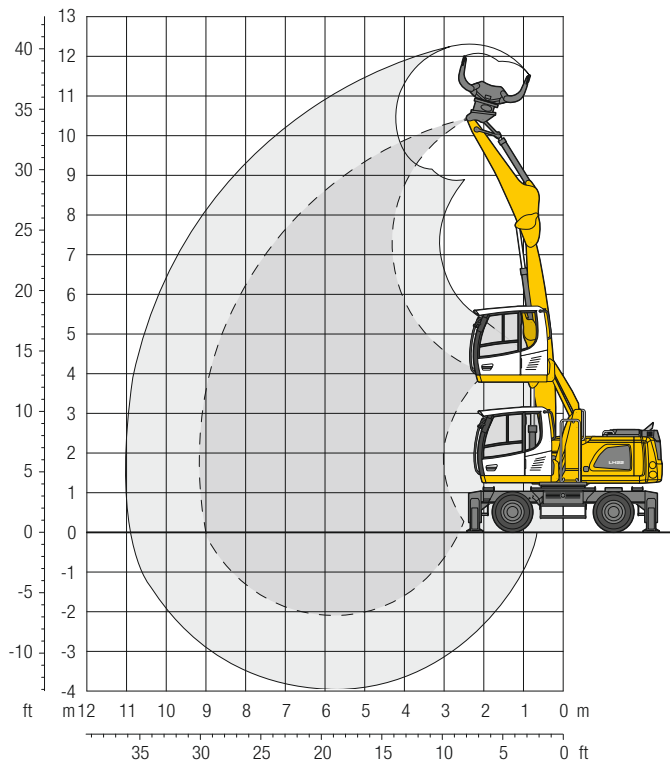

Operating Weight

The operating weight includes the basic machine with 4 point outriggers, hydr. cab elevation, 8 solid tires plus intermediate rings, straight boom 18'1", stick with tipping kinematics 11'6" and sorting grab SG 20B/0.65 yd³ perforated shells.

Weight 50,000 lb

Dimensions

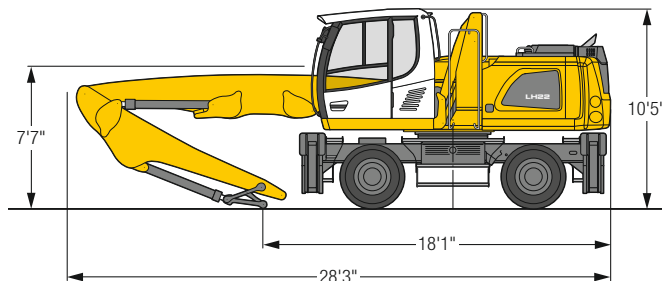

ft	Undercarriage	10 ft		15 ft		20 ft		25 ft		30 ft		ft in	
35	Stabilizers raised 4 pt. outriggers down												
30	Stabilizers raised 4 pt. outriggers down			12,1	15,1*							9,2	11,3*
25	Stabilizers raised 4 pt. outriggers down			12,5	15,5*	7,8	10,4					5,9	8,0
20	Stabilizers raised 4 pt. outriggers down			12,3	15,8*	7,7	10,4	5,2	7,1			4,6	6,4
15	Stabilizers raised 4 pt. outriggers down	16,8*	16,8*	11,7	15,9	7,5	10,1	5,2	7,0			4,0	5,5
10	Stabilizers raised 4 pt. outriggers down	19,5	28,7	10,7	14,9	7,0	9,6	5,0	6,8			3,7	5,1
5	Stabilizers raised 4 pt. outriggers down	2,5*	2,5*	2,5*	2,5*	18,5*	18,5*	13,7*	13,7*	10,7*	10,7*	7,9*	7,9*
0	Stabilizers raised 4 pt. outriggers down	4,6*	4,6*	9,2	13,2	6,2	8,8	4,6	6,4	3,6	5,0	3,6	5,0
-5	Stabilizers raised 4 pt. outriggers down	4,6*	4,6*	17,1*	17,1*	12,5*	12,5*	9,1*	9,1*	6,9*	6,9*	6,8*	6,8*

Height Can be slewed through 360° In longitudinal position of undercarriage Max. reach * Limited by hydr. capacity

The lift capacities on the stick end without attachment are stated in lb x 1,000 and are valid on a firm, level supporting surface with blocked oscillating axle. These capacities can be slewed through 360° with the undercarriage in the transverse position. Capacities in the longitudinal position of the undercarriage (+/- 15°) are specified over the steering axle with the stabilizers raised and over the rigid axle with the stabilizers down. Indicated loads based on the ISO 10567 standard and do not exceed 75% of tipping or 87% of hydraulic capacity. The lift capacity of the unit is limited by its stability, the lifting capability of the hydraulic elements, or the maximum permissible lifting capacity of the load hook.

LH 22 M – Equipment GK10

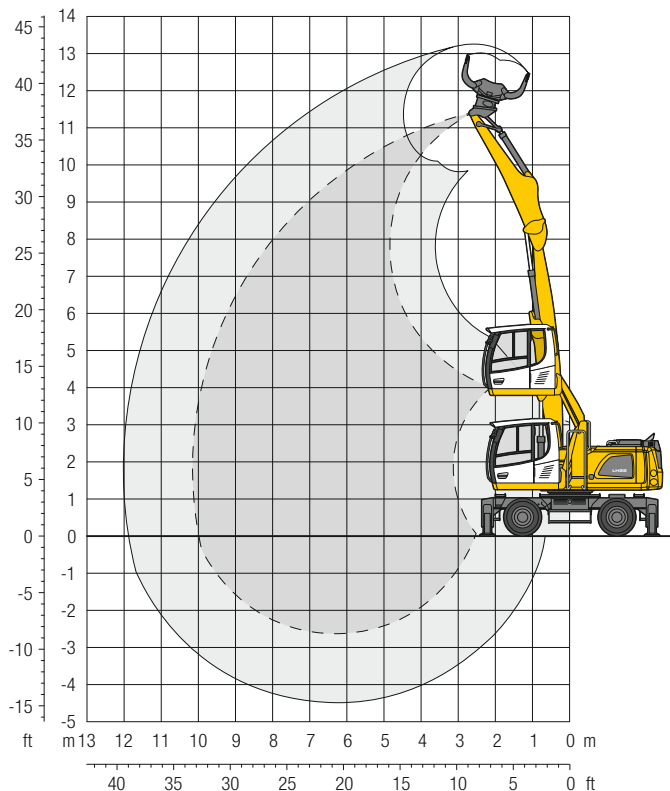

Operating Weight

The operating weight includes the basic machine with 4 point outriggers, hydr. cab elevation, 8 solid tires plus intermediate rings, straight boom 19'8", stick with tipping kinematics 13'1" and sorting grab SG 20B/0.65 yd³ perforated shells.

Weight 50,500 lb

Dimensions

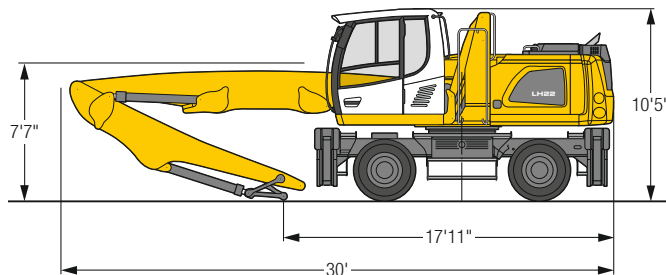

ft	Undercarriage	10 ft		15 ft		20 ft		25 ft		30 ft		ft in		
		Stabilizers raised	4 pt. outriggers down	Stabilizers raised	4 pt. outriggers down	Stabilizers raised	4 pt. outriggers down	Stabilizers raised	4 pt. outriggers down	Stabilizers raised	4 pt. outriggers down	Stabilizers raised	4 pt. outriggers down	ft in
35	Stabilizers raised			11,8	12,2*							11,3	11,6*	15' 5"
	4 pt. outriggers down			12,2*	12,2*							11,6*	11,6*	
30	Stabilizers raised					7,8	10,4					6,0	8,2	22' 8"
	4 pt. outriggers down					12,2*	12,2*					8,6*	8,6*	
25	Stabilizers raised					7,9	10,6	5,3	7,2			4,4	6,0	27' 2"
	4 pt. outriggers down					11,9*	11,9*	10,1*	10,1*			7,6*	7,6*	
20	Stabilizers raised			12,5	15,0*	7,8	10,4	5,2	7,1	3,6	5,1	3,5	5,0	30' 2"
	4 pt. outriggers down			15,0*	15,0*	12,1*	12,1*	10,1*	10,1*	7,6*	7,6*	7,0*	7,0*	
15	Stabilizers raised			11,7	15,9	7,4	10,0	5,0	6,9	3,6	5,1	3,1	4,4	32' 1"
	4 pt. outriggers down			16,3*	16,3*	12,6*	12,6*	10,2*	10,2*	8,1	8,3*	6,8*	6,8*	
10	Stabilizers raised	19,0	28,2*	10,4	14,6	6,8	9,4	4,8	6,6	3,5	4,9	2,9	4,2	33' 1"
	4 pt. outriggers down	28,2*	28,2*	17,9*	17,9*	13,2*	13,2*	10,3*	10,3*	7,9	8,2*	6,5*	6,5*	
5	Stabilizers raised			9,3	13,3	6,2	8,8	4,5	6,3	3,3	4,8	2,8	4,1	33' 4"
	4 pt. outriggers down			18,4*	18,4*	13,2*	13,2*	10,1*	10,1*	7,7*	7,7*	5,7*	5,7*	
0	Stabilizers raised	2,8*	2,8*	8,6	12,6	5,8	8,4	4,2	6,1	3,2	4,7	2,8	4,1	32'10"
	4 pt. outriggers down	2,8*	2,8*	16,6*	16,6*	12,3*	12,3*	9,3*	9,3*	6,7*	6,7*	4,6*	4,6*	
-5	Stabilizers raised			8,4	12,3	5,6	8,2	4,1	6,0			3,3	4,7	29' 8"
	4 pt. outriggers down			13,2*	13,2*	10,2*	10,2*	7,5*	7,5*			4,8*	4,8*	

 Height  Can be slewed through 360°  In longitudinal position of undercarriage  Max. reach * Limited by hydr. capacity

The lift capacities on the stick end without attachment are stated in lb x 1,000 and are valid on a firm, level supporting surface with blocked oscillating axle. These capacities can be slewed through 360° with the undercarriage in the transverse position. Capacities in the longitudinal position of the undercarriage (+/- 15°) are specified over the steering axle with the stabilizers raised and over the rigid axle with the stabilizers down. Indicated loads based on the ISO 10567 standard and do not exceed 75% of tipping or 87% of hydraulic capacity. The lift capacity of the unit is limited by its stability, the lifting capability of the hydraulic elements, or the maximum permissible lifting capacity of the load hook.

LH 22 M – Equipment GF9

Specially designed equipment for indoor application

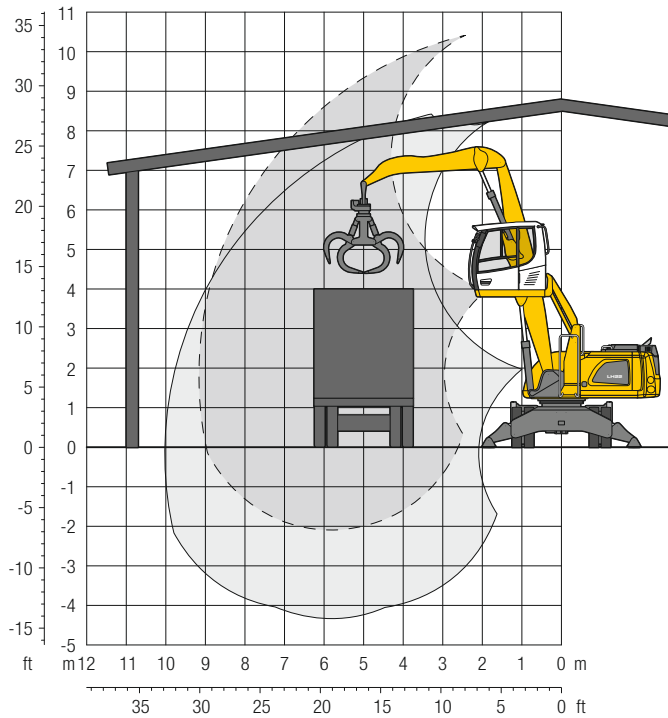

Operating Weight

The operating weight includes the basic machine with 4 point outriggers, hydr. cab elevation, 8 solid tires plus intermediate rings, straight boom 18'1", flat angled stick 11'6" and multi-tine grab GM 55B/0.52 yd³ semi-closed tines.

Weight	49,400 lb
--------	-----------

Dimensions

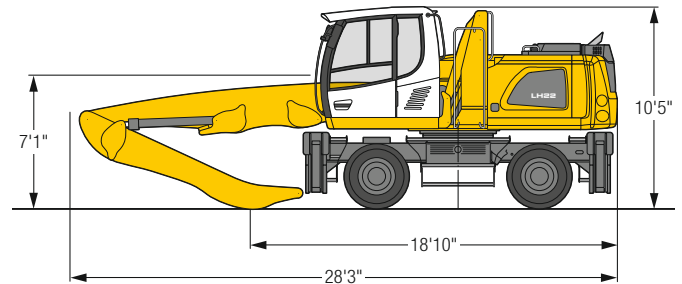

ft	Undercarriage	10 ft		15 ft		20 ft		25 ft		30 ft		ft in		
30	Stabilizers raised			12,5	15,3*							9,8	11,6*	17' 6"
	4 pt. outriggers down			15,3*	15,3*							11,6*	11,6*	
25	Stabilizers raised			12,9	16,0*	8,2	10,8					6,4	8,5	23'
	4 pt. outriggers down			16,0*	16,0*	13,4*	13,4*					9,6*	9,6*	
20	Stabilizers raised			12,8	16,3*	8,2	10,8	5,7	7,6			5,1	6,9	26' 6"
	4 pt. outriggers down			16,3*	16,3*	13,4*	13,4*	11,3*	11,3*			8,8*	8,8*	
15	Stabilizers raised	17,8*	17,8*	12,2	16,4	8,0	10,6	5,7	7,5			4,5	6,1	28' 8"
	4 pt. outriggers down	17,8*	17,8*	17,6*	17,6*	13,8*	13,8*	11,3*	11,3*			8,5*	8,5*	
10	Stabilizers raised	20,2	29,4	11,3	15,5	7,6	10,2	5,5	7,4			4,2	5,7	29'10"
	4 pt. outriggers down	29,8*	29,8*	19,2*	19,2*	14,3*	14,3*	11,3	11,3*			8,5*	8,5*	
5	Stabilizers raised	3,2*	3,2*	10,4	14,5	7,2	9,7	5,3	7,2	4,1	5,6	4,1	5,6	30' 1"
	4 pt. outriggers down	3,2*	3,2*	19,7*	19,7*	14,3*	14,3*	10,9*	10,9*	7,5*	7,5*	7,4*	7,4*	
0	Stabilizers raised	5,3*	5,3*	9,9	14,0	6,9	9,4	5,2	7,0			4,2	5,7	29' 5"
	4 pt. outriggers down	5,3*	5,3*	17,9*	17,9*	13,2*	13,2*	9,8*	9,8*			6,1*	6,1*	
-5	Stabilizers raised			9,8	13,8*	6,8	9,3	5,1	7,0			5,1	6,9	25' 2"
	4 pt. outriggers down			13,8*	13,8*	10,5*	10,5*	7,3*	7,3*			7,1*	7,1*	

Height Can be slewed through 360° In longitudinal position of undercarriage Max. reach * Limited by hydr. capacity

The lift capacities on the stick end without attachment are stated in lb x 1,000 and are valid on a firm, level supporting surface with blocked oscillating axle. These capacities can be slewed through 360° with the undercarriage in the transverse position. Capacities in the longitudinal position of the undercarriage (+/- 15°) are specified over the steering axle with the stabilizers raised and over the rigid axle with the stabilizers down. Indicated loads based on the ISO 10567 standard and do not exceed 75% of tipping or 87% of hydraulic capacity. The lift capacity of the unit is limited by its stability, the lifting capability of the hydraulic elements, or the maximum permissible lifting capacity of the load hook.

LH 22 M – Equipment VK8

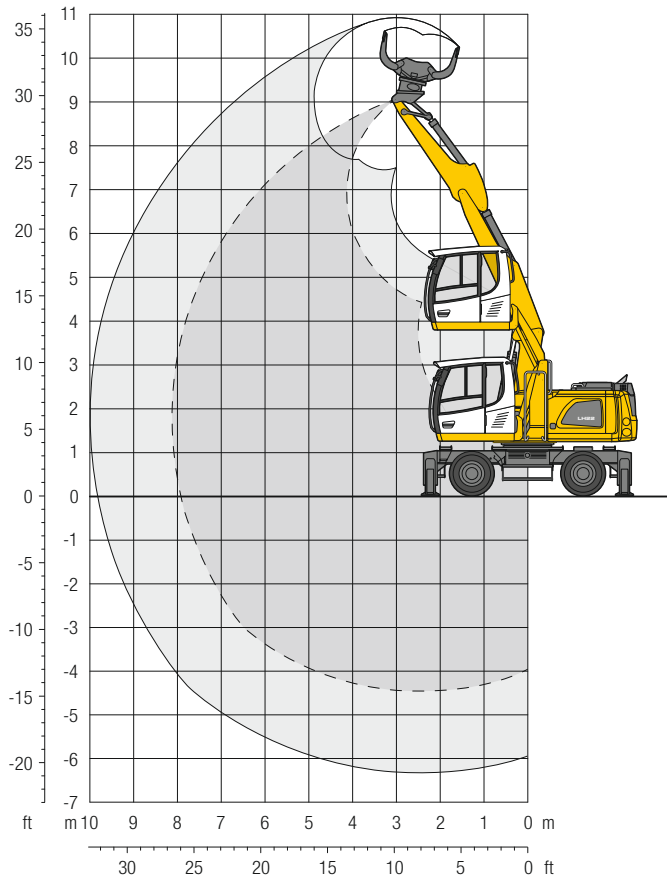

Operating Weight

The operating weight includes the basic machine with 4 point outriggers, hydr. cab elevation, 8 solid tires plus intermediate rings, two-piece boom 17'3", stick with tipping kinematics 8'8" and sorting grab SG 20B/0.65 yd³ perforated shells.

Weight 49,900 lb

Dimensions

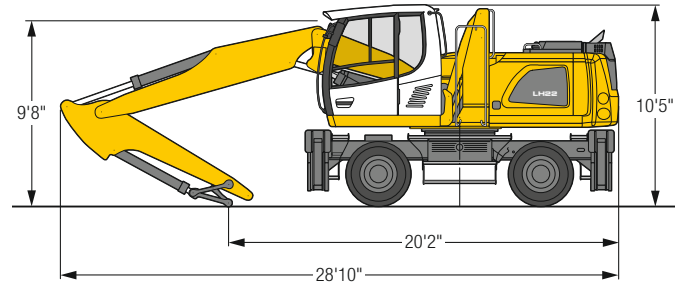

ft	Undercarriage	10 ft		15 ft		20 ft		25 ft		30 ft		ft in		
25	Stabilizers raised			11,1*	11,1*							6,5*	6,5*	18'
	4 pt. outriggers down			11,1*	11,1*							6,5*	6,5*	
20	Stabilizers raised			11,1*	11,1*	8,2	10,0*					5,6*	5,6*	22'5"
	4 pt. outriggers down			11,1*	11,1*	10,0*	10,0*					5,6*	5,6*	
15	Stabilizers raised	14,1*	14,1*	12,3	12,5*	8,3	10,4*					5,3*	5,3*	25'
	4 pt. outriggers down	14,1*	14,1*	12,5*	12,5*	10,4*	10,4*					5,3*	5,3*	
10	Stabilizers raised	20,6*	20,6*	12,0	14,7*	8,2	10,5	5,6	7,4			5,0	5,3*	26'4"
	4 pt. outriggers down	20,6*	20,6*	14,7*	14,7*	11,2*	11,2*	9,3*	9,3*			5,3*	5,3*	
5	Stabilizers raised	20,5	22,9*	11,8	15,2	8,1	10,4	5,4	7,3			4,8	5,5*	26'8"
	4 pt. outriggers down	22,9*	22,9*	16,4*	16,4*	11,9*	11,9*	9,4*	9,4*			5,5*	5,5*	
0	Stabilizers raised	20,7	25,8*	11,9	15,3	7,7	10,3	5,3	7,2			4,9	6,0*	26'
	4 pt. outriggers down	25,8*	25,8*	16,7*	16,7*	12,1*	12,1*	9,1*	9,1*			6,0*	6,0*	
-5	Stabilizers raised	20,2	27,3*	11,4	15,6	7,3	9,9					5,4	7,1*	24'2"
	4 pt. outriggers down	27,3*	27,3*	17,0*	17,0*	12,3*	12,3*					7,1*	7,1*	
-10	Stabilizers raised	20,1	28,2*	10,8	15,0	7,1	8,6*					6,6	6,7*	21'
	4 pt. outriggers down	28,2*	28,2*	16,5*	16,5*	8,6*	8,6*					6,7*	6,7*	

Height Can be slewed through 360° In longitudinal position of undercarriage Max. reach * Limited by hydr. capacity

The lift capacities on the stick end without attachment are stated in lb x 1,000 and are valid on a firm, level supporting surface with blocked oscillating axle. These capacities can be slewed through 360° with the undercarriage in the transverse position. Capacities in the longitudinal position of the undercarriage (+/- 15°) are specified over the steering axle with the stabilizers raised and over the rigid axle with the stabilizers down. The values apply with the optimum positioning of the two-piece boom. Indicated loads based on the ISO 10567 standard and do not exceed 75% of tipping or 87% of hydraulic capacity. The lift capacity of the unit is limited by its stability, the lifting capability of the hydraulic elements, or the maximum permissible lifting capacity of the load hook.

LH 22 C – Equipment GA9

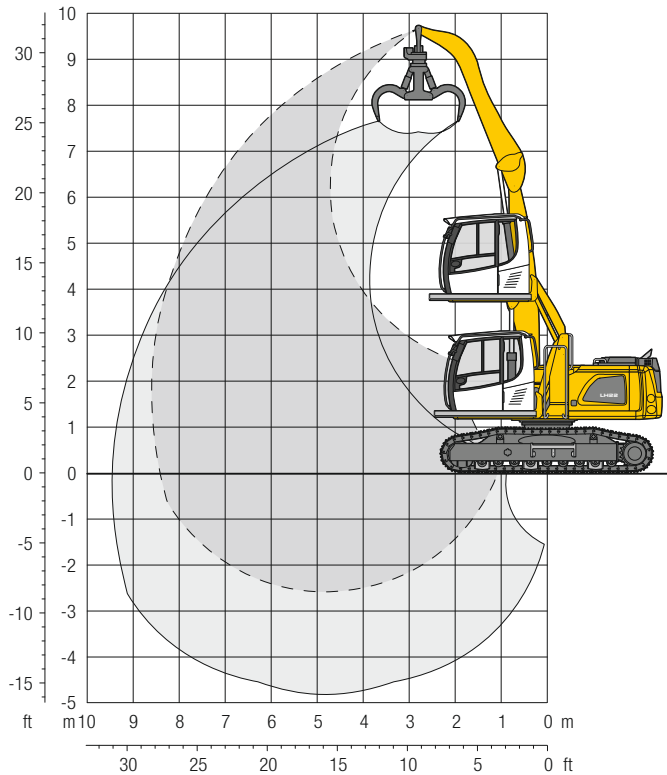

Operating Weight and Ground Pressure

The operating weight includes the basic machine with hydr. cab elevation, straight boom 14'9", angled stick 13'1" and multi-tine grab GM 55B/0.52 yd³ semi-closed tines.

Weight	50,000 lb
Pad width	24"
Ground pressure	on request

Dimensions

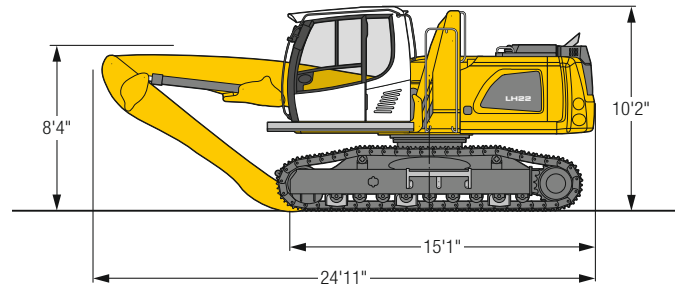

ft	Undercarriage	10 ft		15 ft		20 ft		25 ft		30 ft		ft in		
30	LC											11,8*	11,8*	13'
25	LC			14,2*	14,2*	8,9*	8,9*					8,8*	8,8*	20' 1"
20	LC					11,5	13,3*					7,8*	7,8*	24' 1"
15	LC			15,9*	15,9*	11,4	13,6*	8,1	10,8*			7,4*	7,4*	26' 6"
10	LC			17,2	17,8*	11,1	14,3*	8,0	11,7*			6,8	7,3*	27'11"
5	LC	30,5*	30,5*	16,3	19,9*	10,8	14,8*	7,9	11,5*			6,6	7,6*	28' 2"
0	LC	19,1*	19,1*	15,6	20,2*	10,4	14,5*	7,7	10,4*			6,8	7,7*	27' 8"
-5	LC	17,3*	17,3*	15,3	17,6*	10,3	12,3*					7,6*	7,6*	24'11"

Height Can be slewed through 360° In longitudinal position of undercarriage Max. reach * Limited by hydr. capacity

The lift capacities on the stick end without attachment are stated in lb x 1,000 and can be slewed through 360° on a firm, level supporting surface. Capacities are valid for 24" wide triple grouser pads. Indicated loads based on the ISO 10567 standard and do not exceed 75% of tipping or 87% of hydraulic capacity. The lift capacity of the unit is limited by its stability, the lifting capability of the hydraulic elements, or the maximum permissible lifting capacity of the load hook.

LH 22 C – Equipment GA10

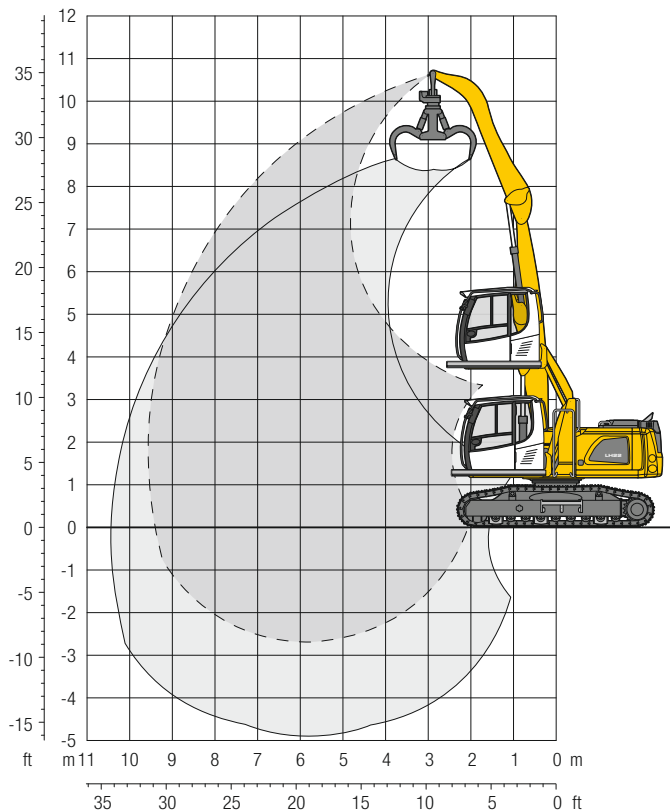

Operating Weight and Ground Pressure

The operating weight includes the basic machine with hydr. cab elevation, straight boom 18'1", angled stick 13'1" and multi-tine grab GM 55B/0.52 yd³ semi-closed tines.

Weight	50,700 lb
Pad width	24"
Ground pressure	on request

Dimensions

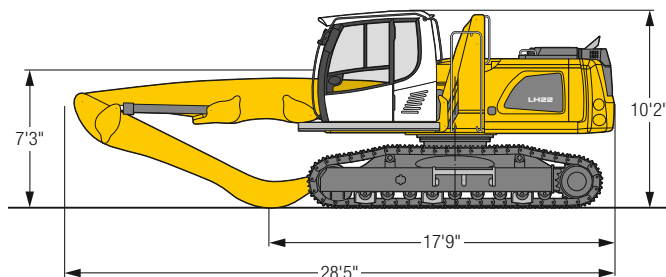

ft	Undercarriage	10 ft		15 ft		20 ft		25 ft		30 ft		ft in		
30	LC			13,8*	13,8*							9,5*	9,5*	19' 1"
25	LC					11,5	12,8*					8,1*	8,1*	24' 5"
20	LC					11,5	12,8*	8,1	11,0*			6,7	7,5*	27'10"
15	LC			16,5*	16,5*	11,2	13,3*	8,0	11,1*			6,0	7,3*	29'11"
10	LC	27,4*	27,4*	16,5	18,3*	10,7	14,0*	7,8	11,2*	5,9	8,9*	5,6	7,4*	31' 1"
5	LC	9,0*	9,0*	15,4	19,6*	10,3	14,3*	7,5	11,1*	5,8	8,4*	5,4	7,4*	31' 5"
0	LC	6,8*	6,8*	14,6	18,9*	9,9	13,8*	7,3	10,4*	5,7	7,2*	5,5	6,3*	30'11"
-5	LC	9,4*	9,4*	14,4	15,7*	9,7	11,8*	7,2	8,6*			6,1*	6,1*	28' 5"

Height Can be slewed through 360° In longitudinal position of undercarriage Max. reach * Limited by hydr. capacity

The lift capacities on the stick end without attachment are stated in lb x 1,000 and can be slewed through 360° on a firm, level supporting surface. Capacities are valid for 24" wide triple grouser pads. Indicated loads based on the ISO 10567 standard and do not exceed 75% of tipping or 87% of hydraulic capacity. The lift capacity of the unit is limited by its stability, the lifting capability of the hydraulic elements, or the maximum permissible lifting capacity of the load hook.

LH 22 C – Equipment GK8

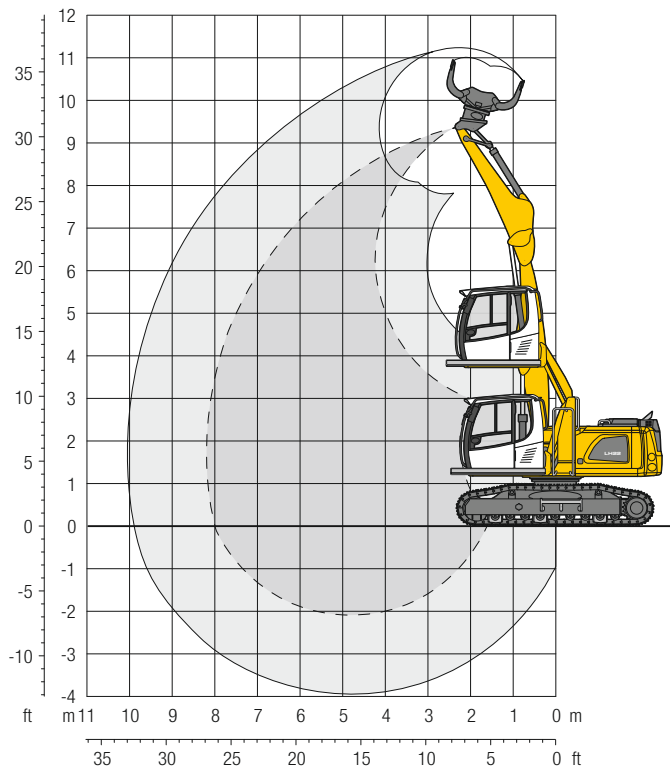

Operating Weight and Ground Pressure

The operating weight includes the basic machine with hydr. cab elevation, straight boom 14'9", stick with tipping kinematics 11'6" and sorting grab SG 20B/0.65 yd³ perforated shells.

Weight	50,500 lb
Pad width	24"
Ground pressure	on request

Dimensions

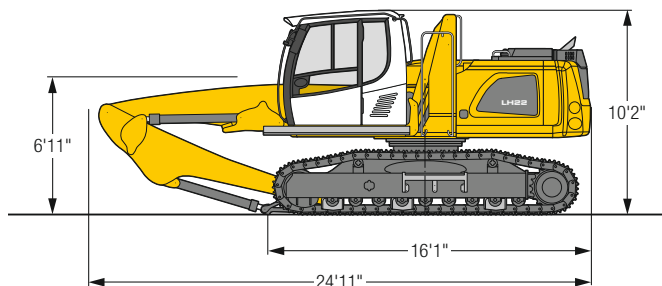

ft	Undercarriage	10 ft		15 ft		20 ft		25 ft		30 ft		ft in		
30	LC			15,3*	15,3*							16,8*	16,8*	9' 5"
25	LC			15,9*	15,9*	10,9	13,6*					10,4*	10,4*	18' 1"
20	LC			16,6*	16,6*	10,8	13,7*	7,5	8,6*			8,8*	8,8*	22' 6"
15	LC			16,4	18,3*	10,5	14,1*	7,5	11,1*			7,5	8,2*	25' 1"
10	LC	20,1*	20,1*	15,6	19,7*	10,2	14,3*	7,4	10,5*			6,8	8,0*	26' 6"
5	LC	13,7*	13,7*	14,7	15,3*	9,8	10,4*					6,6	8,3*	26' 11"
0	LC											6,8	6,9*	26' 4"
-5	LC											8,1*	8,1*	22' 4"

Height **Can be slewed through 360°** **In longitudinal position of undercarriage** **Max. reach** * **Limited by hydr. capacity**

The lift capacities on the stick end without attachment are stated in lb x 1,000 and can be slewed through 360° on a firm, level supporting surface. Capacities are valid for 24" wide triple grouser pads. Indicated loads based on the ISO 10567 standard and do not exceed 75% of tipping or 87% of hydraulic capacity. The lift capacity of the unit is limited by its stability, the lifting capability of the hydraulic elements, or the maximum permissible lifting capacity of the load hook.

LH 22 C – Equipment GK9

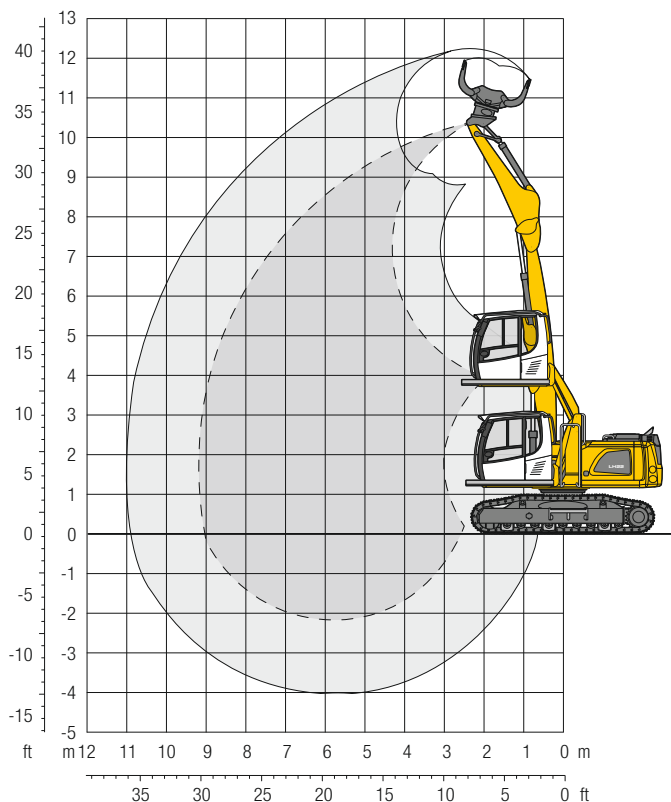

Operating Weight and Ground Pressure

The operating weight includes the basic machine with hydr. cab elevation, straight boom 18'1", stick with tipping kinematics 11'6" and sorting grab SG 20B/0.65 yd³ perforated shells.

Weight	51,100 lb
Pad width	24"
Ground pressure	on request

Dimensions

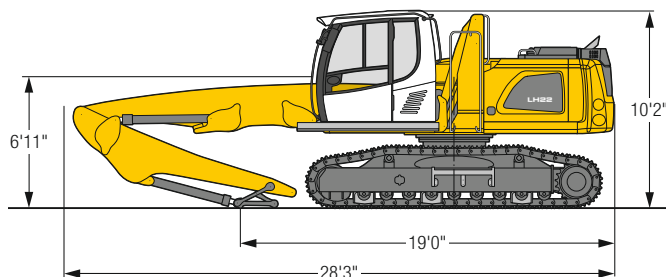

ft	Undercarriage	10 ft		15 ft		20 ft		25 ft		30 ft		ft in		
30	LC			14,6*	14,6*							11,7*	11,7*	16' 10"
25	LC			15,6*	15,6*	10,8	12,9*					8,7	9,4*	22' 8"
20	LC			15,7*	15,7*	10,8	12,8*	7,5	10,7*			6,8	8,5*	26' 4"
15	LC			16,7	16,8*	10,6	13,2*	7,4	10,7*			5,9	8,1*	28' 6"
10	LC	28,6*	28,6*	15,6	18,4*	10,1	13,7*	7,2	10,7*			5,4	8,0*	29' 10"
5	LC	2,6*	2,6*	14,6	19,0*	9,6	13,7*	7,0	10,4*	5,3	7,0*	5,3	6,9*	30' 1"
0	LC	4,2*	4,2*	13,9	17,4*	9,3	12,7*	6,8	9,3*			5,4	5,6*	29' 7"
-5	LC			13,5*	13,5*	9,1	10,2*	6,8	6,9*			6,2*	6,2*	26'

Height Can be slewed through 360° In longitudinal position of undercarriage Max. reach * Limited by hydr. capacity

The lift capacities on the stick end without attachment are stated in lb x 1,000 and can be slewed through 360° on a firm, level supporting surface. Capacities are valid for 24" wide triple grouser pads. Indicated loads based on the ISO 10567 standard and do not exceed 75% of tipping or 87% of hydraulic capacity. The lift capacity of the unit is limited by its stability, the lifting capability of the hydraulic elements, or the maximum permissible lifting capacity of the load hook.

LH 22 C – Equipment GF8

Specially designed equipment for indoor application

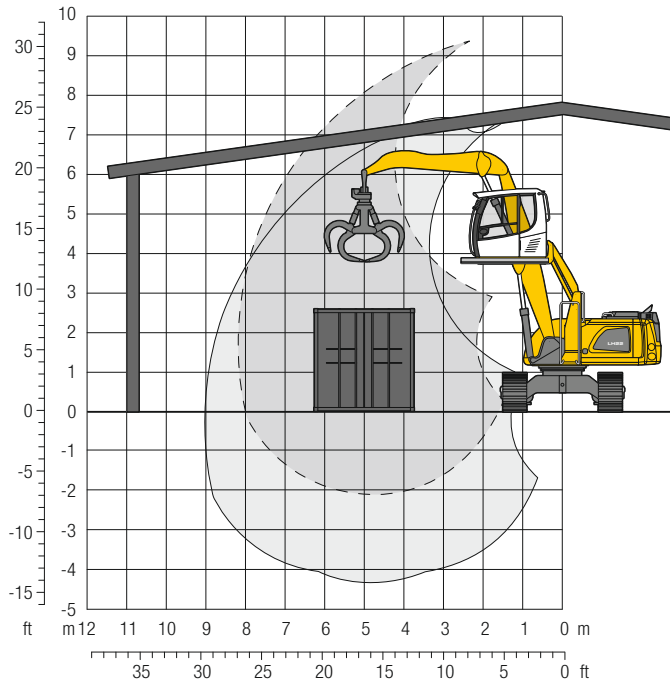

Operating Weight and Ground Pressure

The operating weight includes the basic machine with hydr. cab elevation, straight boom 14'9", flat angled stick 11'6" and multi-tine grab GM 55B/0.52 yd³ semi-closed tines.

Weight	49,800 lb
Pad width	24"
Ground pressure	on request

Dimensions

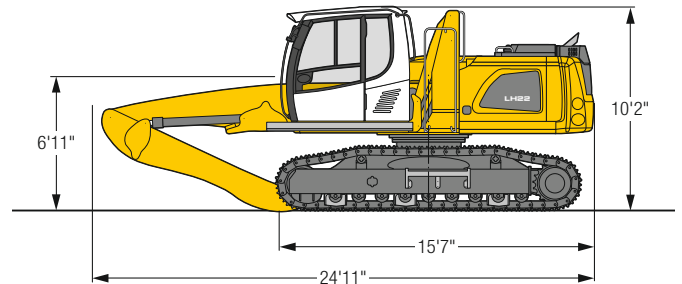

ft	Undercarriage	10 ft		15 ft		20 ft		25 ft		30 ft		ft in
30	LC			15,6*	15,6*					17,0*	17,0*	9' 4"
25	LC			16,4*	16,4*	11,3	14,2*			10,7*	10,7*	18"
20	LC			17,1*	17,1*	11,3	14,3*	8,0	8,8*	9,2*	9,2*	22' 5"
15	LC			16,9	18,9*	11,0	14,7*	8,0	11,6*	7,3	8,5*	26' 5"
10	LC	21,3*	21,3*	16,2	20,4*	10,7	15,0*	7,9	11,1*	7,1	8,7*	26' 10"
5	LC	14,4*	14,4*	15,4	16,1*	10,4	11,1*	7,8	9,4*	7,3	7,6*	26' 2"
0	LC	17,0*	17,0*							8,7*	8,7*	22' 4"

Height Can be slewed through 360° In longitudinal position of undercarriage Max. reach * Limited by hydr. capacity

The lift capacities on the stick end without attachment are stated in lb x 1,000 and can be slewed through 360° on a firm, level supporting surface. Capacities are valid for 24" wide triple grouser pads. Indicated loads based on the ISO 10567 standard and do not exceed 75% of tipping or 87% of hydraulic capacity. The lift capacity of the unit is limited by its stability, the lifting capability of the hydraulic elements, or the maximum permissible lifting capacity of the load hook.

LH 22 C – Equipment VK8

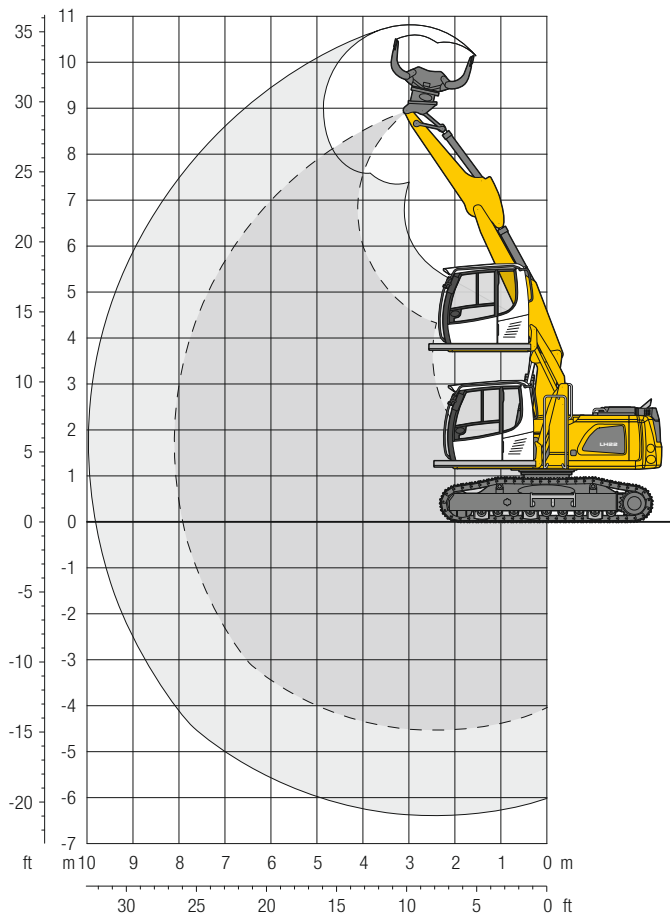

Operating Weight and Ground Pressure

The operating weight includes the basic machine with hydr. cab elevation, two-piece boom 17'3", stick with tipping kinematics 8'8" and sorting grab SG 20B/0.65 yd³ perforated shells.

Weight	51,000 lb
Pad width	24"
Ground pressure	on request

Dimensions

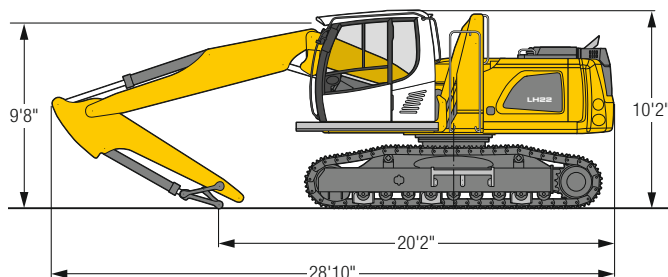

ft	Undercarriage	10 ft		15 ft		20 ft		25 ft		30 ft		ft in		
25	LC			10,9*	10,9*							6,5*	6,5*	17' 7"
20	LC			11,1*	11,1*	10,0*	10,0*					5,6*	5,6*	22' 2"
15	LC	13,4*	13,4*	12,4*	12,4*	10,3*	10,3*					5,3*	5,3*	24' 11"
10	LC	20,5*	20,5*	14,6*	14,6*	10,8	11,1*	7,8	9,3*			5,3*	5,3*	26' 4"
5	LC	22,7*	22,7*	15,7	16,3*	10,7	11,9*	7,6	9,4*			5,5*	5,5*	26' 8"
0	LC	25,6*	25,6*	15,7	16,7*	10,8	12,1*	7,5	9,2*			6,0*	6,0*	26' 1"
-5	LC	27,2*	27,2*	16,2	16,9*	10,4	12,3*					7,0*	7,0*	24' 5"
-10	LC	28,2*	28,2*	15,6	16,7*	9,1*	9,1*					6,6*	6,6*	21' 5"

Height Can be slewed through 360° In longitudinal position of undercarriage Max. reach * Limited by hydr. capacity

The lift capacities on the stick end without attachment are stated in lb x 1,000 and can be slewed through 360° on a firm, level supporting surface. Capacities are valid for 24" wide triple grouser pads. The values apply with the optimum positioning of the two-piece boom. Indicated loads based on the ISO 10567 standard and do not exceed 75% of tipping or 87% of hydraulic capacity. The lift capacity of the unit is limited by its stability, the lifting capability of the hydraulic elements, or the maximum permissible lifting capacity of the load hook.

Machine Stabilities Sorting Grabs

LH 22 M – Max. Material Weight in lb/yd³

Grab	Shell type	Capacity yd ³	Direct mounting with mounting plate						Mounting with SWA 48					
			4 pt. outriggers down			Blade + 2 pt. outriggers down			4 pt. outriggers down			Blade + 2 pt. outriggers down		
			GK9	GK10	VK8	GK9	GK10	VK8	GK9	GK10	VK8	GK9	GK10	VK8
SG 20B	perforated	0.52	5,394	3,371	2,528	3,708	1,686	2,528	4,214	2,191	1,348	2,528	506	1,348
SG 20B	perforated	0.65	4,214	2,528	1,854	2,865	1,180	1,854	3,203	1,517	843	1,854	–	843
SG 20B	perforated	0.78	3,371	1,854	1,348	2,191	843	1,348	2,528	1,180	506	1,348	–	506
SG 20B	perforated	0.92	2,697	1,517	1,011	1,686	506	1,011	2,023	843	–	1,180	–	–
SG 20B	closed	0.52	5,394	3,203	2,360	3,708	1,517	2,360	4,214	2,023	1,180	2,528	–	1,180
SG 20B	closed	0.65	4,045	2,360	1,686	2,697	1,011	1,686	3,203	1,517	843	1,854	–	843
SG 20B	closed	0.78	3,371	1,854	1,348	2,191	843	1,348	2,528	1,180	506	1,348	–	506
SG 20B	closed	0.92	2,697	1,517	1,011	1,686	506	1,011	2,023	843	–	1,011	–	–

– = Load values at maximum outreach insufficient

LH 22 C – Max. Material Weight in lb/yd³

Grab	Shell type	Capacity yd ³	Direct mounting with mounting plate LC-Undercarriage			Mounting with SWA 48 LC-Undercarriage		
			GK8	GK9	VK8	GK8	GK9	VK8
			SG 20B	perforated	0.52	4,551	2,023	2,528
SG 20B	perforated	0.65	3,540	1,517	1,854	2,528	506	843
SG 20B	perforated	0.78	2,697	1,011	1,348	2,023	–	506
SG 20B	perforated	0.92	2,191	843	1,011	1,517	–	–
SG 20B	closed	0.52	4,551	2,023	2,360	3,371	843	1,180
SG 20B	closed	0.65	3,371	1,348	1,686	2,528	506	843
SG 20B	closed	0.78	2,697	1,011	1,348	2,023	–	506
SG 20B	closed	0.92	2,191	843	1,011	1,517	–	–

– = Load values at maximum outreach insufficient

Attachments

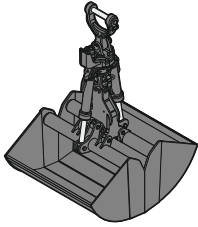

Grab for Loose Material

Shells for loose material with cutting edge (without teeth)

Grab model GM 10B

Width of shells	ft in	3'3"	4'3"	4'11"	5'11"
Capacity	yd ³	1.31	1.70	1.96	2.35
Weight	lb	2.415	2.500	2.635	3.360

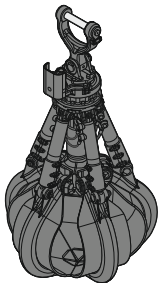

Multi-Tine Grab

open

semi-closed

closed

Grab model GM 64 (4 tines)

Capacity	yd ³	0.52	0.78	0.52	0.78	0.52	0.78	0.78*
Weight	lb	1,765	2,005	2,070	2,335	2,425	2,790	2,590

Grab model GM 55B (5 tines)

Capacity	yd ³	0.52		0.52		0.52*		
Weight	lb	2,195		2,470		3,030		

Grab model GM 65 (5 tines)

Capacity	yd ³	0.52	0.78	0.52	0.78	0.52	0.78	0.78*
Weight	lb	2,590	2,890	2,975	3,285	3,010	3,540	3,320

* heart-shaped

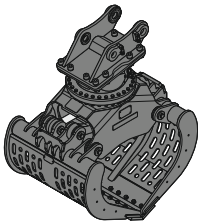

Sorting Grab

per-forated

ribbed

closed

per-forated

ribbed

closed

per-forated

ribbed

closed

per-forated

ribbed

closed

Grab model SG 20B

Width of shells	ft in	2'7"		2'7"	3'3"		3'3"	3'11"		3'11"	4'7"	4'7"
Capacity	yd ³	0.52		0.52	0.65		0.65	0.78		0.78	0.92	0.92
Max. closing force	lbf	8,992		8,992	8,992		8,992	8,992		8,992	8,992	8,992
Weight incl. adapter plate SWA	lb	2,095		2,125	2,195		2,225	2,295		2,315	2,390	2,415

Grab model SG 25B

Width of shells	ft in	2'7"	2'7"	2'7"	3'3"	3'3"	3'3"	3'11"	3'11"	3'11"	4'7"	4'7"
Capacity	yd ³	0.72	0.65	0.72	0.98	0.85	0.98	1.18	1.05	1.18	1.44	1.44
Max. closing force	lbf	13,489	13,489	13,489	13,489	13,489	13,489	13,489	13,489	13,489	13,489	13,489
Weight incl. adapter plate SWA	lb	2,735	2,835	2,780	2,875	3,020	2,930	3,020	3,210	3,085	3,165	3,240

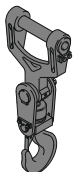

Load Hook

Max. load	lb	27,560
Height with suspension	ft in	3'1"
Weight	lb	210

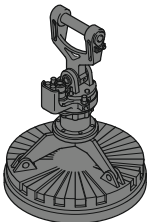



Magnet Devices / Lifting Magnets

Generator	kW	10	10
Electromagnet with suspension			
Power	kW	5.5	8.8
Diameter of magnet	ft in	3'9"	4'1"
Weight	lb	2,480*	3,120*

* only magnet plate

Equipment

 Undercarriage	22 M	22 C
Track pads, variants		+
Individual control outriggers	+	
Shuttle axle lock, automatic	•	
Outrigger monitoring system	+	
Dozer blade	+	
Tires, variants	+	
Protection for travel drive	+	
Protection for piston rods, outriggers	+	
Two lockable storage compartments	•	
Undercarriage, variants	+	

 Uppercarriage	22 M	22 C
Uppercarriage right side light, 1 piece, LED	•	•
Uppercarriage rear light, 2 pieces, LED	+	+
Refuelling system with filling pump	+	+
Generator	+	+
Main battery switch for electrical system	•	•
Recycling package	+	+
Amber beacon, at uppercarriage, LED double flash	+	+
Protection for headlights	+	+
Protection for rear lights	+	+
Tool equipment, extended	+	+

 Hydraulic System	22 M	22 C
Electronic pump regulation	•	•
Liebherr hydraulic oil from -4 °F to +104 °F	•	•
Liebherr hydraulic oil, biologically degradable	+	+
Magnetic rod in hydraulic tank	•	•
Bypass filter	+	+
Preheating hydraulic oil	+	+

 Engine	22 M	22 C
Fuel anti-theft device	+	+
Automatic engine shut-down (time adjustable)	+	+
Preheating fuel	+	+
Preheating coolant*	+	+
Preheating engine oil*	+	+

 Cooling System	22 M	22 C
Radiator, large-mesh, for dust-intensive operation	•	•
Reversible fan drive, fully automatic	+	+
Protective grid (close-mesh) in front of cooler intake, extendible	•	•

 Operator's Cab	22 M	22 C
Stabilizer, control lever, left console	+	
Stabilizer, proportional control on left joystick	•	
Cab lights front, halogen	+	+
Cab lights front, halogen (under rain cover)	•	•
Cab lights front, LED	+	+
Cab lights front, LED (under rain cover)	+	+
Armrest adjustable	•	•
Slewing gear brake Comfort, button on the left or right joystick	+	
Operator's seat Comfort	•	•
Operator's seat Premium	+	+
Driving alarm (acoustic signal is emitted during travel, can be switched ON/OFF)	+	+
Fire extinguisher	+	+
Footrest	+	+
Horn, button on left joystick	•	•
Joystick steering (max. 7.5 mph)	•	
Joystick and wheel steering (slim version)	+	
Cab elevation, hydraulic (LHC)	•	•
Cab elevation, hydraulic with tilt function (LHC)	+	+
Cab elevation, rigid (LFC)	+	+
Automatic air conditioning	•	•
Wheel steering (slim version)	+	
LiDAT, vehicle fleet management	•	•
Proportional control	•	•
Radio Comfort, control via display with handsfree set	+	+
Preparation for radio installation	•	•
Back-up alarm (acoustic signal is emitted traveling backward, can not be switched off)	+	
Amber beacon, on cabin, LED double flash	+	+
Windows made from impact-resistant laminated safety glass	+	+
Windscreen wiper, roof	+	+
Windshield wiper, entire windscreen	•	•
Top guard	+	+
Front guard, adjustable	+	+
Sun visor	+	+
Left control console, folding	•	•

 Equipment	22 M	22 C
Boom lights, 2 pieces, halogen	•	•
Boom lights, 2 pieces, LED	+	+
Stick lights, 2 pieces, halogen	•	•
Stick lights, 2 pieces, LED	+	+
Filter system for attachment	+	+
Height limitation and stick shutoff, electronically	+	+
Boom cylinder cushioning	+	+
Stick camera (with separate monitor), bottom side, with protection	+	+
Liebherr multi coupling system	+	+
Liebherr quick coupler, hydraulic	+	+
Pipe fracture safety valves hoist cylinders	•	•
Pipe fracture safety valves stick cylinders	•	•
Quick coupling system LIKUFIX	+	+
Protection for piston rods, hoist cylinder	+	+
Protection for piston rods, stick cylinder	+	+
Overload warning device	+	+

 Complete Machine	22 M	22 C
Lubrication		
Lubrication undercarriage, manually – decentralized (grease points)	•	
Lubrication undercarriage, manually – centralized (one grease point)	+	
Central lubrication system for uppercarriage and equipment, automatically	•	•
Central lubrication system for undercarriage, automatically	+	
Central lubrication system, extension for attachment	+	+
Special coating		
Special coating, variants	+	+
Monitoring		
Rear view monitoring with camera	•	•
Side view monitoring with camera	•	•

• = Standard, + = Option
 * = country-dependent

Options and / or special equipments, supplied by vendors other than Liebherr, are only to be installed with the knowledge and approval of Liebherr in order to retain warranty.

