

---

# R 978 SME Litronic

---

## LIEBHERR

Crawler excavator



#### Generation

6.2

#### Engine

330 kW / 449 HP  
Stage V

#### Operating weight

Backhoe: 78,350–80,150 kg  
Shovel: 79,100–81,000 kg

#### Bucket capacity

Backhoe: 4.00–5.00 m<sup>3</sup>  
Shovel: 4.00–5.00 m<sup>3</sup>

# Experience progress: R 978 SME Super Mass Excavation

---

## Equipment

---

- Wide choice of backhoe front boom and stick configurations
- Welded structure with cast steel components for improved stress-resistance and longer service life
- Safety check valves to prevent boom and stick cylinder pipes from bursting, with integrated regeneration system for lower fuel consumption

## Buckets

---

- Different levels of protection to suit different areas of application:
  - Standard for loose, non-abrasive materials
  - HD for hard-to-break, moderately abrasive materials
  - HDV for highly abrasive materials
- Different blade designs:
  - straight (for earth-moving and grading)
  - semi-delta (for hard-to-break, hard-to-extract materials)
  - delta (for compacted or slightly cracked materials)



## New functions / options

- **Liebherr Power Efficiency – Engine Control**  
Up to 10% lower fuel consumption
- **Bucket Fill Assist**  
Automatic bucket-filling cycle for increased productivity
- **Modetronic**  
Customisable operating modes for optimum adjustment of work cycles to each type of application

## Comfort

- Quiet, comfortable cab, the largest and most spacious in its category
- Seat with heater and pneumatic multi-directional shock absorption (air conditioning optional)
- High-resolution 9" color touchscreen

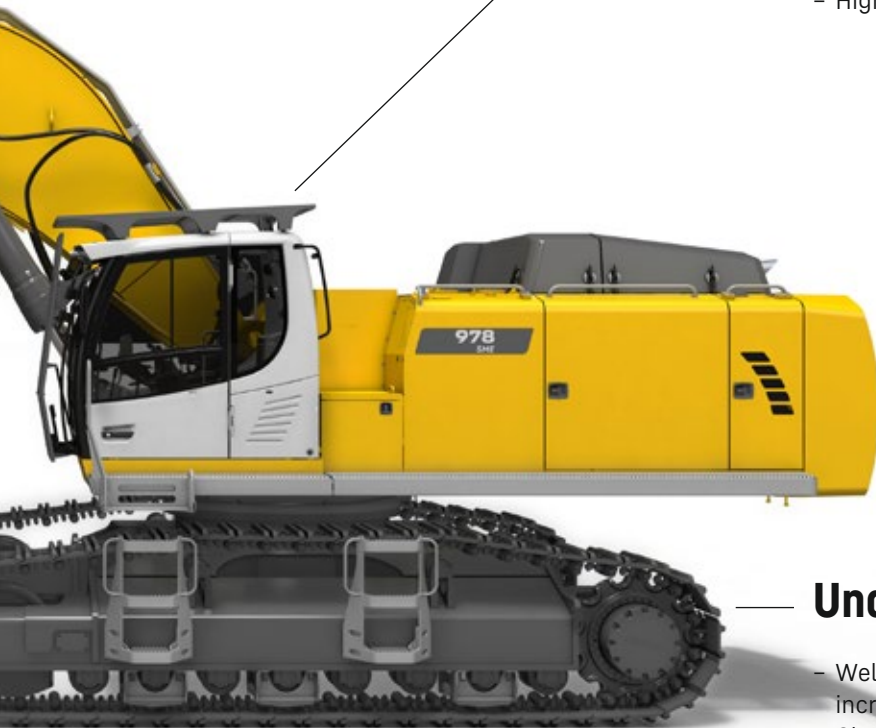

## Undercarriage

- Welded undercarriage with rigid X profile for increased robustness
- Chamfered rack pads with double grouser for more manoeuvrability on difficult terrain
- Moulded two-tooth sprocket for longer service life
- Track rollers on double bearings for increased reliability and durability over time
- Stronger travel motor housing protection for improved resistance to wear and tear from hard, abrasive rocks

# Experience progress: R 978 SME Super Mass Excavation Sho

## Cab

- Cab riser for the best possible view of the loading area
- The largest and quietest cab in its category to date
- Mounted on viscoelastic rivets to absorb vibration
- Impact-resistant windscreen and roof glass panel
- Seat with heater and pneumatic multi-directional shock absorption (air conditioning optional)
- Large high-resolution colour touchscreen

## Safety

- Completely unobstructed panoramic view, plus rear-view and side-view monitoring cameras for increased safety
- Retractable console for safe and easy access to the cab
- Impact-resistant windscreen and roof glass panel
- Cab riser for the best possible view of the loading area (optional)

## Equipment second to none

- Cast steel components
- Shovel attachment with parallel drivetrain for powerful, even penetration
- Bucket cylinders located under the equipment for better protection
- Safety check valves to prevent boom cylinder pipes from bursting
- Front shovel with semi-automatic flap closure, ideally shaped for optimum material penetration and high filling rate



# ovel



## Uppercarriage

- Left and right catwalks as standard; wide catwalks with hand rail optional
- Access platform for engine and hydraulic control block compartments to enable safe, ergonomic maintenance work
- Sleek design for a more extensive view
- New Stage V compliant engine
- Heavier counterweight for more stability and improved performance

## Maintenance

- Access platform for engine and hydraulic control block compartments to enable safe, ergonomic maintenance work
- Left and right catwalks as standard; wide catwalks with hand rail optional
- Automatic central lubrication system as standard
- Shut-off valve on hydraulic tank outlet as standard

## Robust undercarriage

- Fitted with components from the next size up excavator
- Chamfered rack pads with double grouser for more manoeuvrability on difficult terrain
- Moulded two-tooth sprocket for longer service life
- Carrier rollers on double bearings for increased reliability and durability over time
- Stronger travel motor housing protection for improved resistance to wear and tear from hard, abrasive rocks

# Technical data



## Engine

<b>Rating per ISO 9249</b>	330 kW (449 HP) at 1,800 RPM
<b>Torque</b>	2,750 Nm at 1,100 RPM
<b>Model</b>	Liebherr D9508 A7 SCR
<b>Type</b>	8 cylinder V engine
<b>Bore</b>	128 mm
<b>Stroke</b>	157 mm
<b>Displacement</b>	16.16 l
<b>Engine operation</b>	4-stroke diesel Common-Rail
<b>Exhaust gas treatment</b>	Stage V DOC + SCR Filter Passive regeneration by thermo management
<b>Cooling system</b>	Water-cooled and integrated motor oil cooler, after-cooled and fuel cooled
<b>Air cleaner</b>	Dry-type air cleaner with pre-cleaner, primary and safety elements
<b>Fuel tank</b>	1,140 l
<b>Urea tank</b>	180 l
<b>Electrical system</b>	
<b>Voltage</b>	24 V
<b>Batteries</b>	2 x 180 Ah / 12 V
<b>Starter</b>	24 V / 7.8 kW
<b>Alternator</b>	Three-phase current 28 V / 140 A
<b>Engine idling</b>	Sensor controlled
<b>Motor management</b>	Connection to the integrated excavator system controlling via CAN-BUS to the economical utilisation of the service that is available



## Hydraulic controls

<b>Power distribution</b>	Via control valves in single block with integrated safety valves
<b>Flow summation</b>	To boom and stick
<b>Closed-loop circuit</b>	For uppercarriage swing drive
<b>Servo circuit</b>	Electro-hydraulic control
<b>Equipment and swing</b>	Proportional via joystick levers
<b>Travel</b>	- Proportional control via foot pedals or removable levers - Speed pre-selection
<b>Additional functions</b>	Proportional regulation via foot pedals or mini-joystick



## Hydraulic system

<b>Hydraulic pumps</b>	
For equipment and travel drive	Two Liebherr variable displacement, swashplate pumps
<b>Max. flow</b>	2 x 410 l/min.
<b>Max. pressure</b>	350 bar
For swing drive	Reversible, variable displacement, swashplate pump, closed-loop circuit
<b>Max. flow</b>	245 l/min.
<b>Max. pressure</b>	370 bar
<b>Pump regulation</b>	Electro-hydraulic with electronic engine speed sensing regulation, pressure compensation, flow compensation, high flow
<b>Hydraulic tank</b>	435 l
<b>Hydraulic system</b>	920 l
<b>Filtration</b>	2 full flow filters in return line with integrated fine filter area (5 µm)
<b>Cooling system</b>	Compact cooler for water cooler, after-cooler, fuel cooler and transmission pump oil, sandwiched with cooler for oil and condenser of air-conditioning with hydrostatically controlled fan drives
<b>MODE selection</b>	Adjustment of engine and hydraulic performance via a mode pre-selector to match application, e.g. for especially economical and environmentally friendly operation or for maximum digging performance and heavy-duty jobs
<b>RPM adjustment</b>	Stepless adjustment of engine output via RPM at each selected mode
<b>Tool Control</b>	20 pre-adjustable pump flows and pressures for add-on attachments



## Swing drive

<b>Drive</b>	Liebherr swashplate motor with integrated brake valve
<b>Transmission</b>	Liebherr compact planetary reduction gears
<b>Swing ring</b>	Liebherr, sealed race ball bearing swing ring, internal teeth
<b>Swing speed</b>	0-5.6 RPM stepless
<b>Swing torque</b>	233 kNm
<b>Holding brake</b>	Wet multi-disc (spring applied, pressure released)

**Cab**

<b>Cab</b>	LED work headlights integrated in the ceiling, a door with a sliding window (can be opened on both sides), large storing box and several stowing possibilities, shock-absorbing suspension, sound damping insulating, tinted laminated safety glass, separate window shades for the sunroof window and windscreen, cigarette lighter and 12 V plug, storage bins, lunchbox, cup holder
<b>Operator's seat</b>	Liebherr-Comfort seat, airsprung with automatic weight adjustment, vertical and longitudinal seat damping including consoles and joysticks. Seat and armrests adjustable separately and in combination (adjustable in length, height and inclination), seat heating as standard
<b>Arm consoles</b>	Oscillating consoles with seat, tiltable console left
<b>Operation and displays</b>	Large high-resolution operating unit, intuitive, colour display with touchscreen, video-compatible, numerous setting, control and monitoring options, e.g. air conditioning control, fuel consumption, machine and attachment parameters
<b>Air-conditioning</b>	Automatic air-conditioning, recirculated air function, fast de-icing and demisting at the press of a button, air vents can be operated via a menu. Recirculated air and fresh air filters can be easily replaced and are accessible from the outside. Heating-cooling unit, designed for extreme outside temperatures, sensors for solar radiation, inside and outside temperatures The air conditioning system contains fluorinated greenhouse gases
Refrigerant	R134a
Global warming potential	1,430
Quantity at 25 °C*	1,260 g
CO <sub>2</sub> equivalent	1.80 t
<b>Vibration emission**</b>	
Hand / arm vibrations	< 2.5 m/s <sup>2</sup> , according with ISO 5349-1:2001
Whole-body vibrations	< 0.5 m/s <sup>2</sup>
Measuring inaccuracy	According with standard EN 12096:1997
<b>Noise emission</b>	
ISO 6396	72 dB(A) = L <sub>PA</sub> (inside cab)
2000/14/EC	108 dB(A) = L <sub>WA</sub> (surround noise)

\* Valid for standard machine without operator's cab elevation and without height adjustable cab

\*\* For the risk assessment according to 2002/44/EC see ISO/TR 25398:2006



**Undercarriage**

<b>S-HD</b>	Gauge 3,350 mm
<b>Drive</b>	Liebherr swashplate motor with brake valves on both sides
<b>Transmission</b>	Liebherr compact planetary reduction gear
<b>Maximum travel speed</b>	3.5 km/h
<b>Drawbar pull on crawler</b>	568 kN
<b>Track components</b>	D9G, maintenance-free
<b>Track rollers / Carrier rollers</b>	8 / 2
<b>Tracks</b>	Sealed and greased
<b>Track pads</b>	Double grouser
<b>Holding brake</b>	Wet multi-disc (spring applied, pressure released)
<b>Brake valves</b>	Outside the travel motor
<b>Lashing eyes</b>	Integrated

**Equipment**

<b>Type</b>	Combination of resistant steel plates and cast steel components
<b>Hydraulic cylinders</b>	Liebherr cylinders with seal and guidance systems
<b>Bearings</b>	Sealed, low maintenance
<b>Lubrication</b>	Automatic central lubrication system (except link and tilt geometry)
<b>Hydraulic connections</b>	Pipes and hoses equipped with SAE split-flange connections
<b>Buckets</b>	Standard equipped with Liebherr tooth system

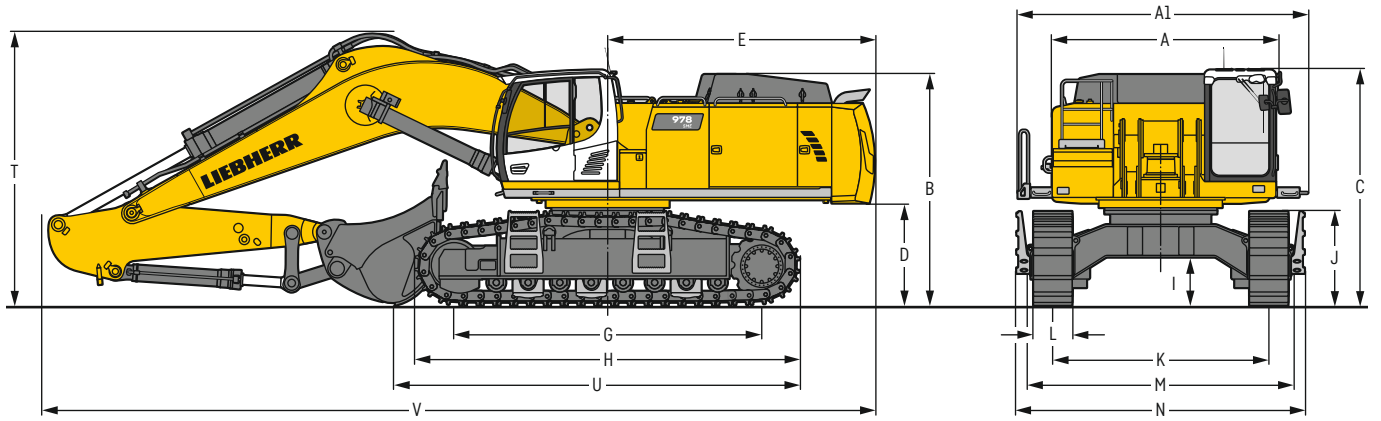
# Dimensions





		S-HD	mm	
A	Uppercarriage width		3,515	
A1	Uppercarriage width with catwalks		4,495	
B	Uppercarriage height		3,585	
C	Cab height		3,665	
D	Counterweight ground clearance		1,585	
E	Rear-end length		4,135	
G	Wheelbase		4,770	
H	Undercarriage length		5,960	
I	Undercarriage ground clearance		745	
J	Track height		1,460	
K	Track gauge		3,350	
L	Track pad width	500	600	750
M	Width over tracks	4,130	4,130	4,130
N	Width over steps	4,760 <sup>1)</sup>	4,760 <sup>1)</sup>	4,760 <sup>1)</sup>

<sup>1)</sup> width with removable steps

		Stick length m	Mono boom SME 7.00 m direct mounting mm
T	Boom height	2.60 SME	4,200
		3.00 SME	4,250
U	Length on ground	2.60 SME	11,500
		3.00 SME	6,300
V	Overall length	2.60 SME	12,800
		3.00 SME	12,900
	Bucket		4.50 m <sup>3</sup>

## Transport dimensions

### removable elements disassembled

	Mono boom SME 7.00 m mm
Transport width	4,495

	Stick m	mm
Transport length	2.60 SME	12,800
	3.00 SME	12,900
Transport height	2.60 SME	4,200
	3.00 SME	4,250
Bucket		4.50 m <sup>3</sup>

# Backhoe bucket

with mono boom SME 7.00 m

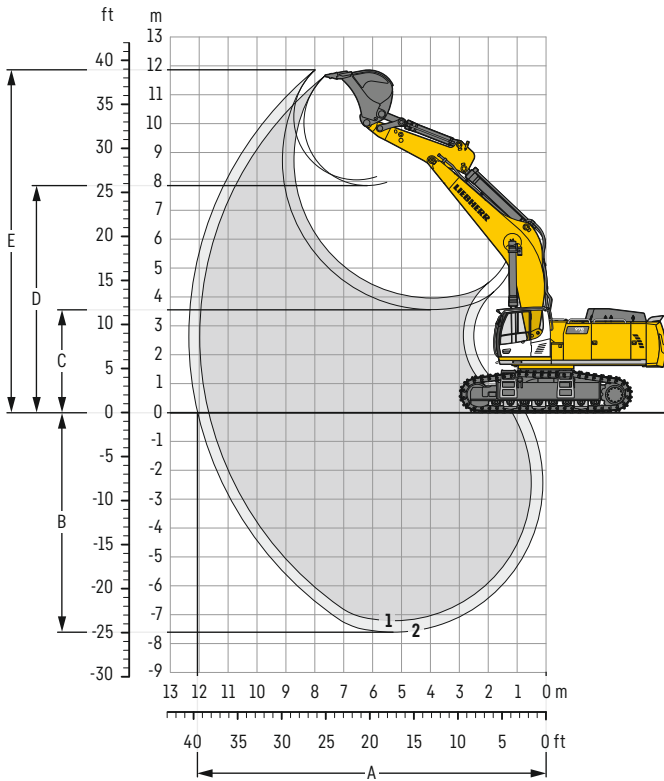

## Digging envelope

without quick coupler		1	2
Stick length	m	2.60	3.00
		SME	SME
A Max. reach at ground level	m	11.65	12.05
B Max. digging depth	m	7.20	7.60
C Min. dumping height	m	3.95	3.55
D Max. dumping height	m	7.85	8.05
E Max. cutting height	m	11.65	11.85

## Forces

without quick coupler		1	2
Stick digging force (ISO 6015)	kN	357	328
Bucket digging force (ISO 6015)	kN	392	392
Stick digging force (SAE J1179)	kN	335	309
Bucket digging force (SAE J1179)	kN	339	339

## Operating weight and ground pressure

The operating weight includes the basic machine with counterweight 14.5 t, mono boom SME 7.00 m, stick SME 2.60 m and HD bucket 4.50 m<sup>3</sup> (4,850 kg).

Undercarriage		S-HD		
Pad width	mm	500	600	750
Weight	kg	78,350	79,050	80,150
Ground pressure	kg/cm <sup>2</sup>	1.54	1.30	1.05

## Buckets Machine stability per ISO 10567\* (75% of tipping capacity)

	Cutting width	Capacity ISO 7451	Weight	S-HD undercarriage SME equipment (with track pads 600 mm)	
				2.60	3.00
HD <sup>1)</sup>	2,200	4.50	4,850	▲	▲
	2,300	5.00	5,050	▲	■
HD <sup>2)</sup>	2,200	4.50	4,950	▲	▲
	2,300	5.00	5,200	▲	■
HDV <sup>3)</sup>	2,000	4.00	5,000	▲	▲
	2,200	4.50	5,350	▲	▲
HDV <sup>4)</sup>	2,300	5.00	5,600	▲	■
	2,000	4.00	5,100	▲	▲
HDV <sup>4)</sup>	2,200	4.50	5,450	▲	▲
	2,300	5.00	5,700	▲	■

\* Indicated loads are based on ISO 10567, at maximum reach, and may be swung 360° on firm and even ground

<sup>1)</sup> HD bucket with teeth Z 90 (appropriate for materials above classification 6, according to VOB, Section C, DIN 18300)

<sup>2)</sup> HD bucket with delta cutting edge and teeth Z 90 (appropriate for materials above classification 6, according to VOB, Section C, DIN 18300)

<sup>3)</sup> HDV bucket with teeth Z 90 (appropriate for materials above classification 6, according to VOB, Section C, DIN 18300)

<sup>4)</sup> HDV bucket with delta cutting edge and teeth Z 90 (appropriate for materials above classification 6, according to VOB, Section C, DIN 18300)

Other buckets available upon request

Max. material weight ▲ = ≤ 2.0t/m<sup>3</sup>, ■ = ≤ 1.8t/m<sup>3</sup>

# Lift capacities

with mono boom SME 7.00 m, counterweight 14.5 t and track pads 600 mm

## Stick SME 2.60 m

Under-carriage m	3.0 m		4.5 m		6.0 m		7.5 m		9.0 m		m	
9.0											13.5* 13.5*	7.3
7.5											12.7* 12.7*	8.5
6.0			23.5* 23.5*								12.5* 12.5*	9.2
4.5				23.5* 23.5*							12.6* 12.6*	9.6
3.0					20.8* 20.8*						14.6* 14.6*	9.8
1.5						24.5* 24.5*					15.0 15.6*	9.7
0			24.6* 24.6*				18.9 19.1*				14.0 14.5*	9.4
-1.5	26.2* 26.2*		29.1* 29.1*				18.2* 18.2*				14.6* 14.6*	8.8
-3.0	29.8* 29.8*		25.4* 25.4*				15.8* 15.8*				14.4* 14.4*	7.9
-4.5			19.0* 19.0*				14.8 15.5*				13.1* 13.1*	6.5

## Stick SME 3.00 m

Under-carriage m	3.0 m		4.5 m		6.0 m		7.5 m		9.0 m		m	
9.0											13.8* 13.8*	7.8
7.5											13.8* 13.8*	8.9
6.0											14.7* 14.7*	9.6
4.5											17.0* 17.0*	10.0
3.0											19.8* 19.8*	10.2
1.5											24.0* 24.0*	10.1
0											26.9* 26.9*	9.8
-1.5	25.4* 25.4*		30.2* 30.2*								18.3* 18.3*	9.2
-3.0	33.6* 33.6*		26.8* 26.8*								16.5* 16.5*	8.4
-4.5			21.1* 21.1*								16.6* 16.6*	7.0

Height Can be slewed through 360° In longitudinal position of undercarriage Max. reach \* Limited by hydr. capacity

The load values are quoted in tons (t) at stick end (without bucket), and may be swung 360° on firm and even ground. Adjacent values are valid for the undercarriage when in the longitudinal position. Capacities are valid for 600 mm wide track pads. Indicated loads are based on ISO 10567 standard and do not exceed 75% of tipping or 87% of hydraulic capacity (indicated via \*). Without bucket cylinder, link and lever the lift capacities will increase by 1,220 kg. Lifting capacity of the excavator is limited by machine stability and hydraulic capacity.

According to European Standard, EN 474-5: In the European Union excavators have to be equipped with an overload warning device, a load diagram and automatic safety check valves on hoist cylinders and stick cylinder(s), when they are used for lifting operations which require the use of lifting accessories.

Determine maximum load lift from load lift chart displayed in the operator's cab or from load lift chart detailed in the operator's manual supplied with the machine.

# Dimensions front shovel

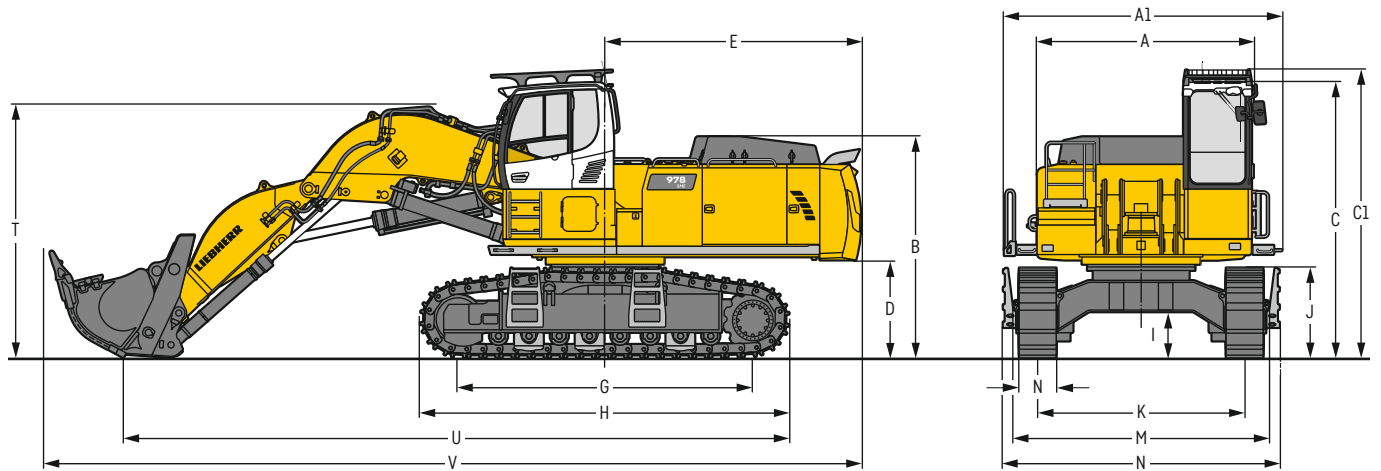

	S-HD	mm		S-HD	mm
A	Uppercarriage width	3,515	I	Undercarriage ground clearance	745
A1	Uppercarriage width with catwalks	4,495	J	Track height	1,460
B	Uppercarriage height	3,585	K	Track gauge	3,350
C	Cab height	4,465	L	Track pad width	500 600 750
C1	Cab height with FOPS top guard	4,660	M	Width over tracks	4,130 4,130 4,130
D	Counterweight ground clearance	1,585	N	Width over steps	4,760 <sup>1)</sup> 4,760 <sup>1)</sup> 4,760 <sup>1)</sup>
E	Rear-end length	4,135	T	Boom height	4,100
G	Wheelbase	4,770	U	Length on ground	10,750
H	Undercarriage length	5,960	V	Overall length	13,200

<sup>1)</sup> width with removable steps

# Transport dimensions

## removable elements disassembled

	Shovel equipment mm
Transport width	4,495
Transport length	13,200
Transport height	4,660
Shovel	4.50m <sup>3</sup>

# Front shovel

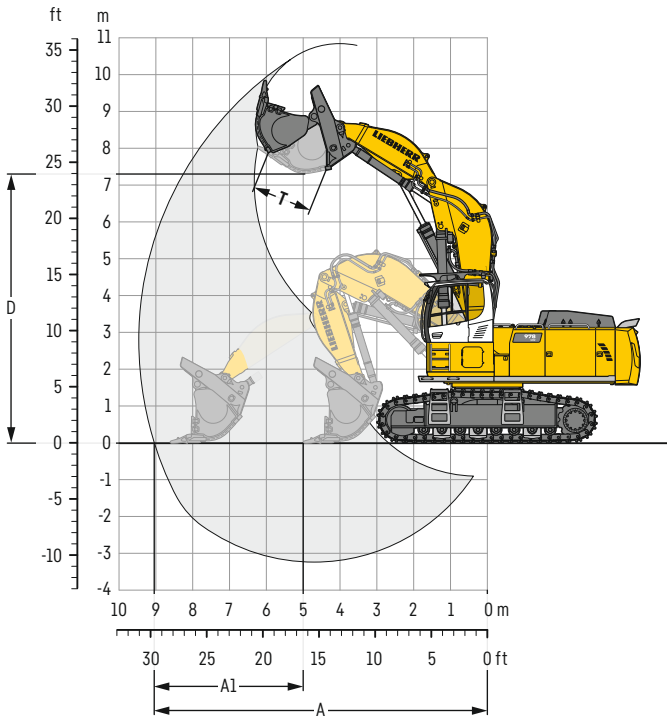

## Digging envelope

A	Max. reach at ground level	m	9.05
A1	Max. crowd length	m	3.60
D	Max. dumping height	m	7.30
T	Bucket opening width	mm	1,650

## Forces

Max. crowd force	kN	500
Max. crowd force at ground level	kN	410
Max. breakout force	kN	370

## Operating weight and ground pressure

The operating weight includes the basic machine with cab elevation 800 mm, shovel equipment SME and front shovel 4.50 m<sup>3</sup> (7,200 kg), level II.

Undercarriage	S-HD			
	mm	500	600	750
Pad width	mm	500	600	750
Weight	kg	79,100	79,900	81,000
Ground pressure	kg/cm <sup>2</sup>	1.55	1.31	1.06

## Front shovels

Cutting width	Capacity ISO 7451	Weight	Wear kit level
mm	m <sup>3</sup>	kg	
2,600	4.00	7,900	III
2,600	4.50	6,700	I
2,600	4.50	7,200	II
2,600	4.50	7,800	III
2,600	5.00	6,800	I
2,600	5.00	7,500	II

## S-HD undercarriage

## Shovel equipment

▲
■
■
▲
▲

Level I: For non-abrasive materials, such as limestone without flint inclusion, shot material or easily breakable rock, i.e., deteriorated rock, soft limestone, shale, etc.

Level II: For pre-blasted heavy rock, or deteriorated, cracked material (classification 3 to 4, according to DIN 18300)

Level III: For highly-abrasive materials such as rock with a high silica content, sandstone etc.

Max. material weight ▲ = ≤ 2.0t/m<sup>3</sup>, ■ = ≤ 1.8t/m<sup>3</sup>, ▲ = ≤ 1.65t/m<sup>3</sup>

# Dimensions and weights

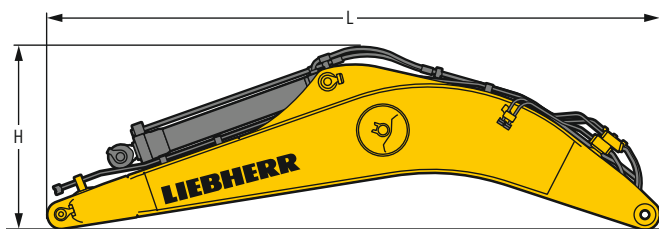
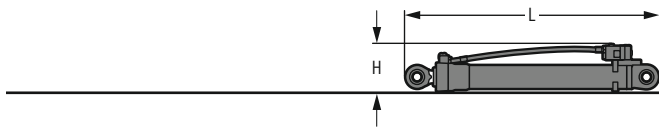
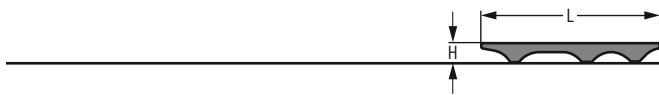
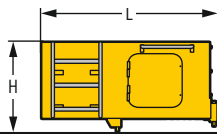
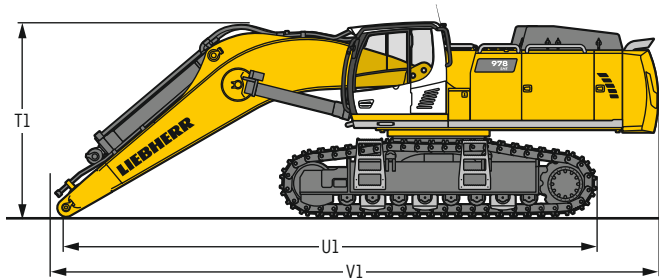
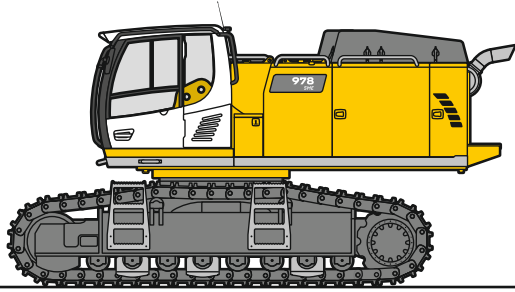

## Basic machine

Track pads	mm	500	600	750
Weight with backhoe equipment and S-HD-undercarriage without counterweight	kg	46,200	46,950	48,050
Weight with shovel equipment and S-HD-undercarriage without counterweight	kg	46,200	46,950	48,050

## Machine without stick

T1	mm	3,650
U1	mm	10,050
V1	mm	11,450

## Cab elevation

800 mm

L Length	mm	1,890
H Height	mm	930
Width	mm	1,370
Weight	kg	600

## Counterweight

L Length	mm	770
H Height	mm	1,550
Width	mm	3,360
Weight	kg	14,500

## Upper protection screen

L Length	mm	1,960
H Height	mm	190
Width	mm	1,110
Weight	kg	75

## Hoist cylinders (two)

L Length	mm	2,650
H Height	mm	490
Width	mm	360
Weight	kg	2 x 750

## Mono boom with stick cylinder

Boom length	m	7.00
L Length	mm	7,350
H Height	mm	2,250
Width	mm	1,450
Weight	kg	7,350

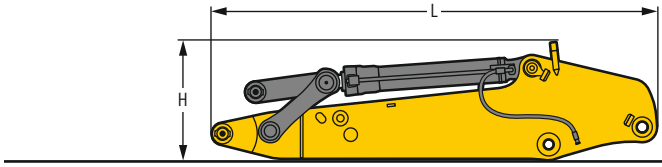

### Stick with bucket cylinder

Stick length	m	2,60	3,00
L Length	mm	4,000	4,400
H Height	mm	1,350	1,350
Width	mm	950	950
Weight	kg	3,900	4,150

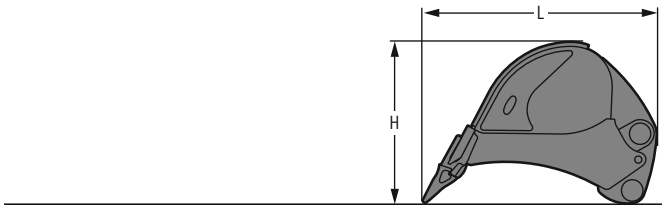

### Backhoe buckets

HD

Cutting width	mm	2,200	2,300	2,200*	2,300*
Capacity	m <sup>3</sup>	4,50	5,00	4,50	5,00
L Length	mm	2,650	2,650	2,750	2,750
H Height	mm	1,800	1,800	1,850	1,850
Width	mm	2,250	2,350	2,250	2,350
Weight	kg	4,850	5,050	4,950	5,200

\* with delta cutting edge

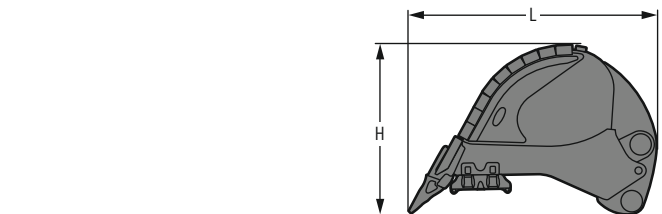

### Backhoe buckets

HDV

Cutting width	mm	2,000	2,200	2,300	2,000*	2,200*	2,300*
Capacity	m <sup>3</sup>	4,00	4,50	5,00	4,00	4,50	5,00
L Length	mm	2,650	2,650	2,650	2,750	2,750	2,750
H Height	mm	1,800	1,800	1,800	1,850	1,850	1,850
Width	mm	2,050	2,250	2,350	2,050	2,250	2,350
Weight	kg	5,000	5,350	5,600	5,100	5,450	5,700

\* with delta cutting edge

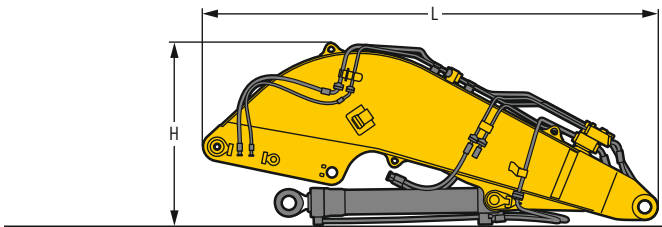

### Shovel boom

L Length	mm	4,750
H Height	mm	1,950
Width	mm	1,900
Weight without crowd cylinder	kg	5,050
Weight crowd cylinder	kg	650

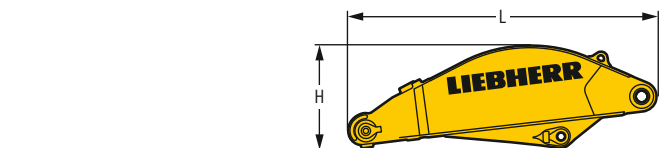

### Shovel stick

L Length	mm	3,250
H Height	mm	1,100
Width	mm	1,500
Weight	kg	2,500



### Shovel bucket cylinders (two)

L Length	mm	2,550
H Height	mm	350
Width	mm	500
Weight	kg	2 x 400

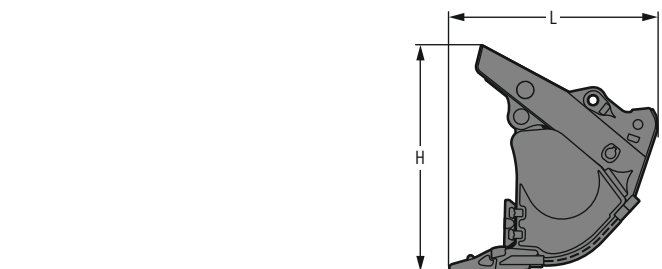

### Front shovels

Cutting width	mm	2,600	2,600	2,600
Capacity	m <sup>3</sup>	4,00	4,50	5,00
L Length	mm	2,200	2,200	2,300
H Height	mm	2,400	2,400	2,500
Width	mm	2,650	2,650	2,650
Weight				
Level I	kg	-	6,700	6,800
Level II	kg	-	7,200	7,500
Level III	kg	7,900	7,800	-

# Serial equipment

## Undercarriage

Lashing eyes  
Sprocket with dirt ejector  
Track and carrier rollers, sealed and lifetime-lubricated  
Travel motor housing protection  
Undercarriage S-HD

## Uppercarriage

Access platforms without protruding parts  
Anti-skid surfaces  
Automatic swing brake lock  
Centralised lubrication system (automatic)  
Counterweight heavy 14.5 t  
DEF tank lockable access hatch  
Engine hood with gas spring opening  
Extended tool set including tool box  
Handrails  
Liebherr Power Efficiency – Engine Control  
Lockable fuel tank cap with padlock  
Lockable service doors  
Lockable storage box  
Main switch, accessible from ground level  
Pre-heating system for fuel  
Protection grid on radiator fan  
Sound insulation  
Swing-out radiators  
Windshield washer fluid tank

## Hydraulic system

Dedicated swing circuit  
Filter with integrated fine filters  
Hydraulic pressure measuring ports  
Hydraulic tank shut-off valve  
Magnetic rod  
Pressure accumulator for controlled lowering of equipment with engine turned off

## Engine

Air filter with automatic dust ejector  
Automatic engine idling / speed increase, controlled via joystick sensors  
Common-Rail injection system  
Exhaust gas after-treatment system – DOC + SCR  
Fixed geometry turbocharger  
Fuel fine filter  
Fuel pre-filter and water separator  
Fuel priming pump  
Intercooler  
Power Pack EU Stage V  
Stepless adjustable engine speed

## Cab

9" multifunction colour touchscreen  
Air conditioning, automatic, tri-zone, controlled via display  
Armrests adjustable in length, height and inclination  
Bottle holder  
Cab door sliding windows  
Cigarette lighter  
Coat hook  
DEF consumption on touchscreen  
DEF level on touchscreen  
Electric socket in cabin (12 V)  
Electric socket in cabin (24 V)  
Emergency hammer  
Engine oil level on touchscreen  
Footrest  
Fuel consumption on touchscreen  
Fuel level on touchscreen  
Impact resistant roof window  
Impact resistant two-piece windscreen  
Interior lighting  
Laminated right hand side window  
LiDAT Plus (Liebherr data transfer system)\*  
Mobile phone storage net  
Modetronic  
Movement priority between swing and boom, adjustable via touchscreen  
Rain hood over front window opening  
Rearview mirror  
Rear view monitoring camera  
Rear view monitoring camera distance gauge  
Rear window emergency exit  
Right hand side view monitoring camera  
Roll-down sun blinds for windscreen and roof window  
Rubber floor mat, fixed on floor and removable  
Storage box  
Storage nets  
Storage spaces  
Tilttable console left  
Tinted windows  
Visco-elastic damping  
Windscreen wiper and washer  
Work mode selector

## Equipment

Anti-drift system boom cylinders  
Anti-drift system stick cylinder  
Boom bottom protection  
Boom cylinders regeneration  
Pipe fracture safety valve for stick cylinder  
Pipe fracture safety valves for boom cylinders  
Pivot points made of cast steel  
SAE split flanges on high pressure lines  
Stick bottom protection  
Stick cylinder regeneration

\* optionally extendable after one year



# Equipment standard / option

## Undercarriage

Chain guide 3 pieces	●
Chain guide full length	+
Reinforced cover and base plate for undercarriage centre section	+
Special painting	+
Steps	●
Track pads double grouser 500 mm, chamfered	+
Track pads double grouser 600 mm, chamfered	●
Track pads double grouser 750 mm, chamfered	+
Travel drive gearbox protection	+
Undercarriage protection plate for drop-ball application	+

## Upper carriage

Air pre-filter with cyclonical dust trap	+
Boxing ring	+
Catwalks left and right	●
Catwalk wide with railing	+
Electric socket on uppercarriage (24 V)	+
Filter for hydraulic hammer return flow	+
Fixed cab riser 800 mm	+
Headlight on uppercarriage, lateral right, LED+, 1 piece	+ <sup>1)</sup>
Headlights on uppercarriage, front, LED, 2 pieces, protections included	● <sup>1)</sup>
Headlights on uppercarriage, front, LED+, 2 pieces, protections included	+ <sup>1)</sup>
Headlights on uppercarriage, rear, LED+, 2 pieces	+ <sup>1)</sup>
Lighting for tank area	+ <sup>1)</sup>
Lighting for uppercarriage access	+ <sup>1)</sup>
Radiator fine mesh protection grid	+
Reversible fan drive	+
Skyview 360°	+
Special painting	+
Swing ring and lubrication hoses protection	+
Tank refilling pump fuel	+
Wiggins coupling for fuel	+

## Hydraulic system

Bypass filter for hydraulic oil	+
Liebherr hydraulic oil	●
Liebherr hydraulic oil, adapted for extreme climate conditions	+
Liebherr hydraulic oil, biodegradable	+

## Engine

Automatic engine shutdown after idling	+
Engine shut-down with overrun	+
Lighting for engine compartment	+ <sup>1)</sup>

## Cab

2" seat belt with retractor	●
3" seat belt with retractor, orange colour	+
4-points seat belt	+
Acoustic travel alarm deactivatable	+
Auxiliary heater programmable	+
Bottom windscreen wiper	+
Coming / Leaving Home	+ <sup>1)</sup>
Cool box (12 V)	+
Dark tinted windows	+
Electrically adjustable and heated outside rear-view mirrors	+
Electronic immobiliser	+
Emergency stop in cab	+
FGPS front guard tiltable	+
Fire extinguisher	+
First-aid box	+
FOPS top guard	+
Handrests elevated for joysticks	+
Headlights on cab, front, LED, 2 pieces	● <sup>1)</sup>
Headlights on cab, front, LED+, 2 pieces	+ <sup>1)</sup>
Headlights on cab roof, front, LED+, 2 pieces	+ <sup>1)</sup>
High pressure circuit switchable on pedals or mini-joystick	+
High pressure circuit with Tool Control (20 attachment adjustments on display)	+
Lighting for cabin access	+ <sup>1)</sup>
Luminosity control (LED+ headlights)	+ <sup>1)</sup>
Medium pressure circuit	+
Mini-joysticks proportional	+
Operator seat Comfort	●
Operator seat Premium	+
Overload warning system	+
Radio Comfort	+
Radio pre-installation	●
Roof sun shield	+
Roof window wiper	+
Rotating beacon on cabin, LED, 1 piece	+
Shortcut button on joystick configurable	●
Special painting	+
Sun visor	+

## Equipment

Boom cylinder rods protection	+
Bucket cylinder rod protection	+
Bucket Fill Assist	+
Centralised lubrication extended for connecting link	+
Floating boom	+
Headlights on boom, LED, 2 pieces, protections included	● <sup>1)</sup>
Headlights on boom, LED+, 2 pieces, protections included	+ <sup>1)</sup>
Mono boom SME 7.00 m	+
Preparation for ripper tooth	+
Quick coupler SWA 92 hydraulic	+
Shovel boom 4.50 m	+
Shovel stick 2.90 m	+
Special painting	+
Stick SME 2.60 m	+
Stick SME 3.00 m	+

● = Standard, + = Option

<sup>1)</sup> Equipment not individually available, but only as predefined packages

Non-exhaustive list, please contact us for further information.

Options and / or special equipment, supplied by vendors other than Liebherr, are only to be installed with the knowledge and approval of Liebherr in order to retain warranty.





# The Liebherr Group



## Global and independent: more than 70 years of success

Liebherr was founded in 1949 when, with the development of the world's first mobile tower crane, Hans Liebherr laid the foundations for a family business now employing nearly 51,000 people and comprising over 140 companies across every continent.

The parent company is Liebherr-International AG in Bulle, Switzerland, whose associates are exclusively members of the Liebherr family.

## Leaders and pioneers

Liebherr is a pioneer and its forward-looking approach has seen it make important contributions to technology history over a wide variety of industries. Employees throughout the world continue to share the courage of the founder, sharing a passion to produce innovative products and a determination to provide world-leading equipment and machinery.

## Diversified portfolio

The company is one of the world's biggest construction equipment manufacturers and provides high-quality, user-oriented products and services to sectors including: earthmoving, material handling, deep foundations, mining, mobile and crawler cranes, tower cranes, concrete production and distribution, maritime cranes, aerospace and transportation, gear technology and automation, refrigeration and freezing, components and hotels.

## Customised care

Liebherr solutions are characterised by precision, implementation and longevity. The company is committed to technological excellence and to providing customers with solutions that match their needs exactly. That customer focus does not end with delivery of a product but continues through a comprehensive range of back-up and support services.

[www.liebherr.com](http://www.liebherr.com)

## Liebherr-France SAS

2 avenue Joseph Rey, B.P. 90287 • 68005 Colmar Cedex, France • Phone +33 389 213030  
info.lfr@liebherr.com • [www.liebherr.com](http://www.liebherr.com) • [www.facebook.com/LiebherrConstruction](https://www.facebook.com/LiebherrConstruction)