LH 80 Industry Litronic

LIEBHERR

Material handling machine

Generation

6

Operating weight

146,600–265,700 lb*

Engine

308 HP / 230 kW

Stage V

Stage IIIA (compliant)

Tier 4 Final

Electric

System performance

437 kW (Diesel)

427 kW (Electric)

* Without attachment

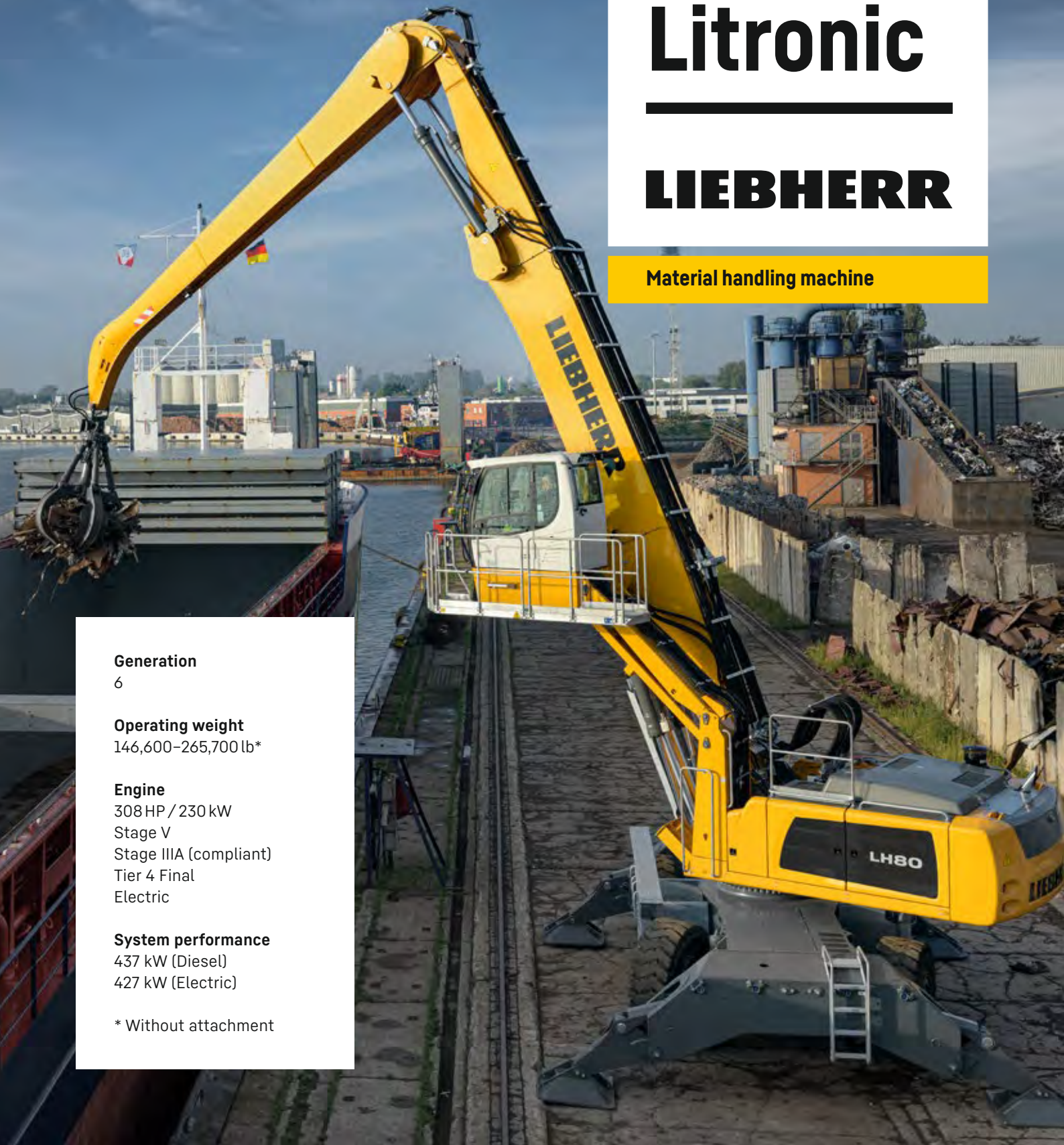

Performance

Power plus speed –
Redefined performance

Economy

Good investment –
Savings for long-term

Reliability

Durability and sustainability –
Quality down to the last detail

Comfort

Perfection at a glance –
When technology is comfortable

Maintainability

Efficiency bonus –
Even with maintenance and service



LH 80 M Industry Litronic

Operating weight
157,600–181,900 lb*

Engine
308 HP / 230 kW
Stage V
Stage IIIA (compliant)
Tier 4 Final
Electric

System performance
437 kW (Diesel)
427 kW (Electric)

LH 80 M High Rise Industry Litronic

Operating weight
190,700–220,000 lb*

Engine
308 HP / 230 kW
Stage V
Stage IIIA (compliant)
Tier 4 Final
Electric

System performance
437 kW (Diesel)
427 kW (Electric)

* Without attachment



LH 80 C Industry Litronic

Operating weight
146,600–194,000 lb*

Engine
308 HP / 230 kW
Stage V
Stage IIIA (compliant)
Tier 4 Final
Electric

System performance
437 kW (Diesel)
427 kW (Electric)

LH 80 C Gantry Industry Litronic

Operating weight
193,600–227,000 lb*

Engine
308 HP / 230 kW
Stage V
Stage IIIA (compliant)
Tier 4 Final
Electric

System performance
437 kW (Diesel)
427 kW (Electric)

LH 80 C Gantry Industry Litronic

Operating weight
236,300–265,700 lb*

Engine
308 HP / 230 kW
Stage V
Stage IIIA (compliant)
Tier 4 Final
Electric

System performance
437 kW (Diesel)
427 kW (Electric)

Performance



Power plus speed – redefined performance

Liebherr has been designing and manufacturing market leading material handling machines for over 60 years. With the different versions of the LH 80 Industry machine model of the generation of Liebherr handlers, high performance and yet economical machines specially designed for use in scrap recycling, timber yards and for handling of bulk materials.

Maximum handling capacity

Powerful drive unit

The LH 80 Industry material handling machine is equipped with a powerful Liebherr 6-cylinder in-line engine with 3.2 gal displacement or optionally with a 230 kW electric motor with a frequency converter. This ensures the machine's high performance while further reducing fuel and energy consumption.

High swing torque

The separate hydraulic pump in the closed slewing circuit only supplies hydraulic fluid to the swing mechanism. The maximum delivery volume is thus available at any time for turning the uppercarriage for fast and dynamic rotational movements.

Energy recovery system ERC

Lowering the equipment in the ERC system provides the machine with additional stored energy. This results in increased system performance, which in turn enables more powerful, faster and more homogeneous work cycles and increases handling performance.

Precision operation

LSC Hydraulic system with electrical pilot control

The 2-circuit Liebherr-Synchron-Comfort-system (LSC) with LUDV technology (flow distribution independent of load pressure) ensures faster working movements with up to 20% less energy consumption.

All work functions of the machine are controlled electrically, whereby the signals of the transmitters are only converted directly at the control block by hydraulic means. This technology enables end position damping of the equipment in order to protect the components and thus extend their service life. Simple, individual setting and adjustment of the working speed of boom, stick and slewing mechanism allow the driver to adjust the machine to each application and fully utilize the machine's capacity.

Firm and stable positioning

An essential prerequisite for precise working and maximum handling capacity is the firm and stable positioning of the machine. The design of the Liebherr undercarriage optimizes the way forces are induced on components to minimize stress and guarantee maximum stability and durability.



Liebherr diesel engine

- Powerful, robust and reliable
- Maximum torque even at low speeds to ensure fast movements with low fuel consumption
- Common-Rail injection system for maximum efficiency
- Emissions treatment with Liebherr SCR technology



Closed slewing circuit

- High torque for maximum acceleration and fast rotary movements
- Integrated speed sensor for controlling and monitoring braking movement for greater safety
- Greater fuel efficiency thanks to intelligent energy management in the closed system



Electrical pilot control

- Precision control irrespective of the ambient temperature for maximum precision
- Simpler and faster fault diagnostics for optimal availability
- Up to 5 individual driver profiles can be saved

Economy



Good investment – savings for the long-term

Liebherr material handling machines combine high productivity with excellent economy thanks to the use of in-house components as well as sophisticated engine technology and highly efficient demand-controlled hydraulics.

Increased productivity

Engine idling and engine shut-down

The standard automatic idling function reduces the engine speed to idle as soon as the operator takes his hand from the joystick so that no hydraulic function is activated. Proximity sensors in the joystick levers restore the original engine speed as soon as the operator's hand is moved towards the lever again. This ensures that the set engine speed is available immediately. The result is a combination of energy saving and reduced noise levels. Operating costs can be reduced even further with the optional automatic engine shut-down function.

Closed hydraulic circuit for the swing mechanism

The closed slewing circuit feeds the braking energy back into the system when the uppercarriage is braked. Here, new standards are set in terms of efficiency and economy. Simple yet effective.

Attachments and quick coupling systems

Liebherr offers a wide selection of attachments for every application to increase the productivity of its material handling machines. In addition the material handlers can be fitted with a Liebherr quick coupling system which increase the productivity of the machine by up to 30%. The matching attachment and quick coupling system combined with the outstanding dynamics of a Liebherr handler ensures highest handling capacity and maximum productivity.

Electrical efficiency

Electric drive concept

The electric drives offer an economical and sustainable solution in the field of material handling. The drive motors operate in an environmentally friendly and emission-free manner, which makes them independent of any exhaust emission standards. A significant reduction in operating and service costs is achieved due to the elimination of maintenance work such as oil changes and fuelling breaks, as well as longer service intervals compared to diesel models. This increase in efficiency results in optimal working times and increased productivity in the field. In addition, the low-vibration and low-noise operation ensures improved working comfort.

Sustainable profitability with electric machines

An investment in an electric material handling machine pays off in the long term. These advanced drives offer numerous advantages that enable fast amortisation of the machine and significant cost savings compared to conventional diesel engines. Given the growing importance of environmental criteria and emissions, electric drives are an economical alternative that ensures both sustainable profitability and environmentally friendly operation.

Liebherr Power Efficiency (LPE) System

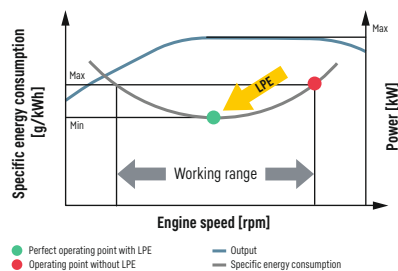

Low energy consumption thanks to intelligent machine control

- Liebherr-Power Efficiency (LPE) optimizes the interaction of the drive components in terms of efficiency
- LPE enables machine operation in the area of the lowest specific energy use for less consumption and greater efficiency with the same performance

Liebherr attachments

- Robust and service-friendly slewing drive, can be turned 360°
- Optimum filling and clamping performance for effective material handling
- Finite element method (FEM) optimized for a perfect relationship between grapple weight, volume and a very long service life

Frequency converters

- Individual adjustment of the speed
- Smooth start-up to avoid inrush current peaks and high energy savings due to effective start-up current limitation
- Simple adjustment to all conventional power supply networks

Reliability



Durability and sustainability – quality down to the last detail

Every day Liebherr material handlers demonstrate their qualities in a range of industrial applications all over the world. Years of experience, continuous development and the latest technologies provide maximum safety in use. Their robust design and the use of components produced in-house ensure that the LH 80 is designed for a long service life.

More safety

Pipe fracture safety valves

The standard pipe fracture safety valves on the stick and hoist cylinders prevent the equipment from dropping in an unregulated way and ensure maximum safety during every operation.

Working range limiters

For operations in which the working range should be limited, the material handling machines can be specified with an optional working range limitation feature. Collisions and resulting component damage can thus be avoided.

Overload warning device and load torque limitation

The audible and visual overload warning system continuously tells the operator about the current load situation of the machine. Furthermore, load torque limitation automatically regulates the speed of the working hydraulics to allow the maximum load bearing capacity to be approached safely. In the event of an overload, the functions which could cause the machine to topple are disabled. Only movements back to the safe working range are then possible.

High machine availability

Quality and competence

Our experience, understanding of customer needs and the technical implementation of these findings guarantee the success of our products. For decades, Liebherr has been inspirational with its depth of production and system solutions. Key components such as the diesel engine, electronic components, slew ring, swivel drive and hydraulic cylinders are developed and produced by Liebherr itself. The great extent of in-house manufacturing guarantees maximum quality and ensures that components are optimally configured to each other.

Robust design

All steel components are designed and manufactured by Liebherr. High-strength steel plates configured for the toughest of requirements result in high torsional stiffness and optimum absorption of forces to give a longer service life.

Intelligent self diagnostics

The innovative control electronics permanently monitor the vital functions of the machine to guarantee a high level of machine availability. Components which are critical for safety have a secondary redundancy feature to guarantee maximum safety and reliability.



QPDM – quality and process data management

- QPDM allows production data to be logged, documented and evaluated
- Test specifications and machine documented automatically logged
- Ability to handle large quantities of data while maintaining uniform high quality



Piston rod protection

- Maximum protection of piston rod
- Robust construction of hot-dip galvanized steel for a long service life in tough applications
- Available for outriggers, hoist cylinders, ERC cylinder and tip cylinder as an option



Equipment

- Components enhanced using FEM for maximum service life even if subjected to heavy lateral stresses during demanding tasks
- Cables routed internally to protect them from damage
- High load capacities with long reaches
- Reaches up to 72 ft

Comfort



Perfection at a glance – when technology is comfortable

The Liebherr deluxe cab is spacious, has an ergonomic design and is very quiet. This ensures that the operator remains intent and fully concentrated throughout the working day and enables him to deliver a constantly high performance.

Deluxe cab

Ergonomic design

The cab design provides excellent conditions for healthy, focused and productive work in maximum comfort. The color touchscreen display, the controls and operator's comfort seat are all coordinated to form a perfect ergonomic unit. In addition the ergonomic joysticks allow the machine operation to be both pleasant and precise.

Excellent all around vision

The large areas of glass, different versions of cab elevations and the rear and side area monitoring systems provide the operator with an excellent view of his working area and the zone around the machine. This perfect view enhances the operator's safety and ensures that he can handle the machine safely at all times.

Low noise levels

The use of viscoelastic mounts, good insulation and low noise diesel engines from Liebherr minimises noise emissions and vibrations. Both electric and diesel-powered machines produce extremely low sound levels, which means they are classed as low-noise machines that are not harmful to people and the environment.

Comfortable operation

Proportional Control

Precision control of the material handling machine is especially important in applications such as waste separation or scrap recycling. Thanks to the standard proportional control, even such demanding operations can be mastered with ease.

Joystick steering and stabilizing

The standard joystick steering gives the operator an additional comfort boost. The steering movement can be conveniently executed using the joystick, eliminating the need to reposition during the work cycle. Substituting the steering wheel in favor of joystick steering provides additional leg-room and a clear view of the working area. A standard feature is the control of the outriggers with the joystick for more comfort and an increased productivity of the machine.

Color touchscreen display and operation unit

The 9" color touchscreen display is intuitive in its operation and provides continuous information about all important operating data. The shortcut keys can be individually assigned and are selected quickly and easily with the menu strip.



Safe access

- Foldable left arm console, as well as wide, non-slip steps, catwalks and platforms, and ergonomically positioned handles for easy and safe access
- All access systems are designed to national guidelines and statutory regulations
- Sliding door for comfortable entry with narrow platforms is available as an option



Operator's seat comfort with adjustable armrests

- Greater seating comfort due to variable damper hardness, lockable horizontal suspension, pneumatic lumbar support, seat heating and passive seat air conditioning for concentrated working
- Individual adjustment options for armrests, seat cushion depth, seat angle and head restraint for healthful working



Joystick with proportional control

- Good functionality with streamlined, ergonomic design
- 4-way mini joystick can be used to control all operations e.g. steering, outriggers and attachments etc.
- Joysticks - each with two buttons and a rocker switch - increase the number of functions available

Maintainability



Efficiency bonus – even with maintenance and service

The Liebherr LH 80 material handling machine is powerful, robust, precise and efficient. It also features integral maintenance benefits as a result of their service-based machine design. The maintenance work for the Liebherr material handler can be carried out quickly, easily and safely. This minimizes machine's maintenance costs and downtime.

Efficient maintenance concept

Service-based machine design

The service-based machine design guarantees short servicing times, thus minimizing maintenance costs. All the service points are positioned in close proximity to one another, are easily accessible from the ground or on catwalks and platforms, and easy to reach thanks to the large, wide-opening service doors. This means that service work can be completed even more quickly and efficiently.

Integral maintenance benefits

Maintenance work helps to keep the machine fully functional. However this kind of work leads to machine downtimes which must be minimized. With change intervals of up to 2,000 hours for engine oil and up to 8,000 hours for hydraulic oil, Liebherr has significantly reduced the amount of maintenance and increased the productivity of the material handlers. In addition, central lubrication systems minimize daily maintenance. Above all, electric material handling machines are characterised by their low maintenance requirements.

Your competent service partner

Remanufacturing

The Liebherr remanufacturing program offers cost-effective reconditioning of components to the highest quality standards. Various reconditioning levels are available: Replacement components, general overhaul or repair. The customer receives components with original part quality at a reduced cost.

Competent advice and service

Competent advice is a given at Liebherr. Experienced specialist provide decision guidance for your specific requirements: application-oriented sales support, service agreements, economical repair alternatives, original parts management, as well as remote data transmission for machine planning and fleet management.



Lubrication as it works

- Fully automatic central lubrication system for uppercarriage and equipment
- Fully automatic central lubrication system for the undercarriage available as an option
- Lubricates without interrupting work to ensure better productivity and a long component service life



Servicing advantages for electrical machines

- Low operating and maintenance costs
- Significantly longer maintenance intervals compared to diesel engines due to a lower number of wear parts
- Cost savings on servicing
- Maximum productivity due to permanent readiness of the machine



Rapid spare parts service

- 24-hour delivery: Spare parts service is available for our dealers around the clock
- Electronic spare parts catalogue: Fast and reliable selection and ordering via the Liebherr online portal
- With online tracking, the current processing status of your order can be viewed at any time

Material handling machines overview

Equipment

- High load capacities and long reach thanks to optimized kinematic properties and robust construction for greater handling performance
- Energy recovery cylinder filled with nitrogen for maximum efficiency through less energy consumption at more handling capacity
- Pipe fracture safety valves on hoist and stick cylinders and retract stick shut-off for maximum safety during every application
- Quick coupling systems and attachments made by Liebherr for maximum machine capacity, utilization and greater handling performance

Operator's cab

- Joystick steering without steering column as standard for convenient operation, greater legroom and clear view of the working area
- Less strain on the operator, workers and reduced environmental pollution due to lower noise emissions
- Optimum visibility thanks to large glass surfaces and standard rear and side area monitoring with camera
- Proportional control is standard with 4-way mini joystick for greater precision, high precision control and functions





Uppercarriage

- 2-circuit Liebherr-Synchron-Comfort-system (LSC) with LUDV technology for faster working speed at up to 20% less energy consumption
- 230 kW engine output and greater pump flow for fast work cycles, convincing dynamics and maximum handling performance
- Electrical pilot control enables individual settings for the operator and an end position damping of the equipment
- Reduction in operating costs thanks to built-in maintenance advantages and optimum service accessibility
- Frequency converter provides the direct energy supply and control for the electric motor*

Undercarriage

- Optimized hydraulics with closed slewing mechanism circuit for greater energy efficiency and faster work cycles
- Central lubrication system (manual/ full automatic) for more productive working time (optional available)
- Load-holding valves fitted as standard on all support cylinders for maximum stability in every application
- Low service costs thanks to travel drive without gearbox and cardan shafts
- Different cable variants for flexible applications and high mobility*

* only with electric

The perfect solution for every application

Attachments

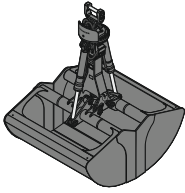

Shells for loose material



Multi-tine grab



Wood grab

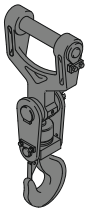

Load hook

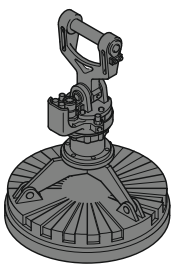

Magnet devices

Sticks

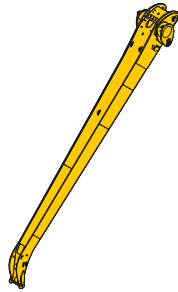

Angled stick

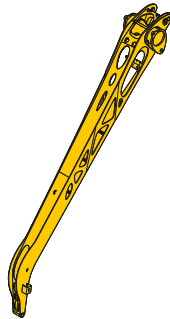

Lightweight stick

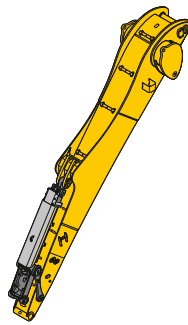

Stick with tipping kinematics

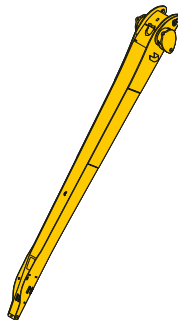

Straight stick

Booms

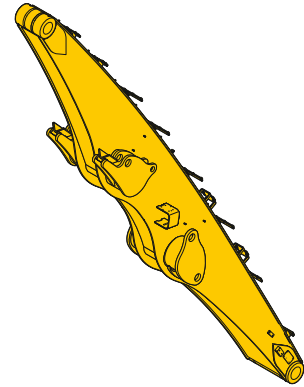

Straight boom

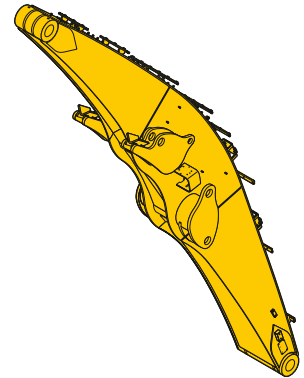

Angled boom

Cab elevations

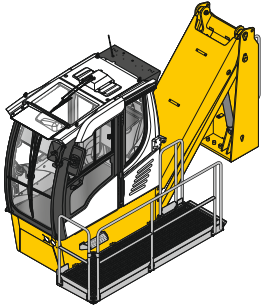

Hydraulic cab elevation

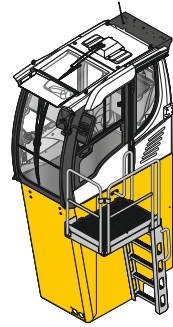

Rigid cab elevation

Uppercarriage

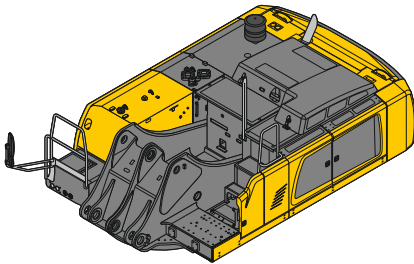

Diesel

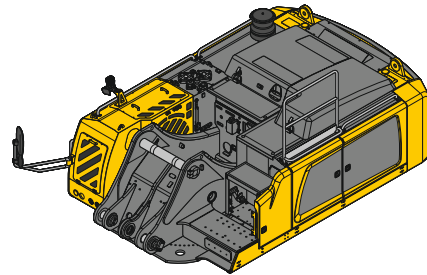

Electric

Turret elevations

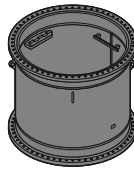

Undercarriage

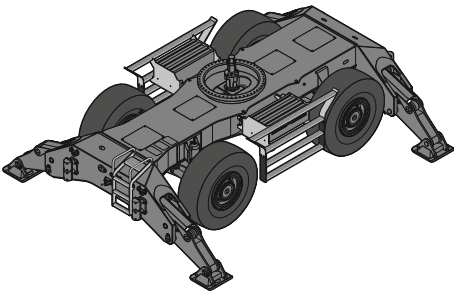

Mobile

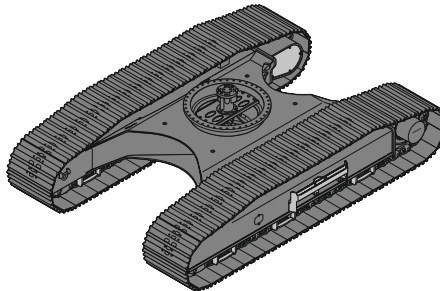

Crawler

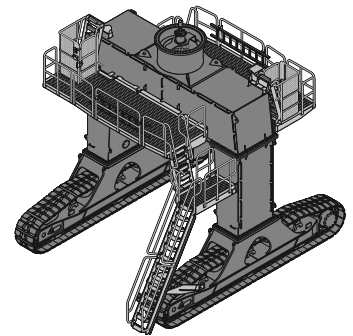

Gantry

Experience the progress

The invention of the mobile tower crane in 1949 also marked the birth of the Liebherr company. During its first decade the small construction company developed into an established manufacturer of construction machines and other technically advanced products. The R 353 and its first industrial equipment were launched in 1951 to lay the

foundations for the production of today's material handling machines. The A 911 mobile material handling machine a few years later enabled the company to make the breakthrough into material handling. Over the years the machines have been developed continually and today they are designed uncompromising for the industrial use.

1949

First tower crane TK10



1968

Breakthrough with the A 911 mobile material handler



1974

Silenced material handling machine



R 353 with the first industrial equipment

1961



Production plant in Kirchdorf

1970



First hydraulic cab elevation

1983

Liebherr has now been developing and manufacturing material handling machines for a very wide range of applications in the scrap, port and timber handling sectors and for the waste and recycling industry for over 60 years. In the development of its machines, Liebherr chooses quality, durability and reliability from the very outset, together with performance and economy. Years of experience in design and con-

struction are not only reflected in the end product but also in the components which are developed, designed and manufactured by Liebherr itself. This multiple sector expertise is used in product design from the early phase of the development process and thus allows high level technical innovations to be made.

2007

Opening of the assembly building for material handling machines



2013

Launch of the new LH series



2016

Launch of the new port material handling machines



Awarded the Bauma Design Prize for the LH 120

2010



Awarded the Bauma Innovation Prize for the ERC cylinder



Awarded the IF Award for the material handling machine LH 60

2014

Technical data

Diesel engine

Rating per SAE J1349 per ISO 9249	308 HP (230 kW) at 1,800 rpm 313 HP (230 kW) at 1,800 rpm
Model	Liebherr D946
Type	6 cylinder in-line
Bore / Stroke	5.1 / 5.9 in
Displacement	729 in ³
Engine operation	4-stroke diesel Common-Rail Turbo-charged and after-cooled Reduced emissions
Air cleaner	Dry-type air cleaner with pre-cleaner, primary and safety elements
Engine idling	Sensor controlled
Electrical system	
Voltage	24 V
Batteries	2 x 180 Ah / 12 V
Alternator	Three-phase current 28 V / 140 A
Stage V	
Harmful emissions values	According to regulation (EU) 2016/1628
Emission control	Liebherr-SCRFilter technology
Fuel tank	174 gal
Urea tank	17 gal
Stage IIIA (compliant)	
Harmful emissions values	In accordance with ECE-R.96 Power Band H
Fuel tank	174 gal
Tier 4 Final	
Harmful emissions values	In accordance with 40CFR1039 (EPA) / 13CCR (CARB)
Emission control	Liebherr-SCR technology
Fuel tank	174 gal
Urea tank	17 gal

Electric motor

Rating	220 kW at 1,800 rpm
Type	Three-phase squirrel cage motor
Secondary electric motor	Electric motor auxiliary equipment (air-conditioning compressor, alternator 24 V) 15 kW
Electrical system energy supply	Frequency converter fed drive system Heavy-duty version
Supply voltage	
Low voltage	380 V, 400 V
Frequency	50 / 60 Hz
Engine idling	Sensor controlled
Electrical system	Battery-assisted Control system, lighting, diagnostics system
Voltage	24 V
Batteries	2 x 135 Ah / 12 V
Alternator	Three-phase current 28 V / 140 A

Deviating parameters of the power supply system must always be clarified with Liebherr-Hydraulikbagger GmbH.

Cooling system

Diesel engine	Water-cooled Cooling system, consisting of a cooling unit for water and charge air and a 2nd cooler for hydraulic oil, each with an infinitely variable, thermostatically controlled fan drive system
Electric motor	Air-cooled Cooling system for hydraulic oil with an infinitely variable, thermostatically controlled fan drive system

Hydraulic controls

Power distribution	Via control valves with integrated safety valves, simultaneous actuation of chassis and equipment. Swing drive in separate closed circuit
Servo circuit Equipment and swing	With electro-hydraulic pilot control and proportional joystick levers
Chassis mobile	Electro-proportional via foot pedal
Chassis crawler	With electric proportionally functioning foot pedals or adjusted with plugable levers
Additional functions Proportional control	Via switch or electro-proportional foot pedals Proportionally acting transmitters on the joysticks for additional hydraulic functions

Hydraulic system

Hydraulic pump For equipment and travel drive	2 Liebherr axial piston variable displacement pumps (double construction)
Max. flow	2 x 96 gpm
Max. pressure	5,076 psi
For swing drive	Reversible axial piston variable displacement pump, closed-loop circuit
Max. flow	52 gpm
Max. pressure	5,366 psi
Hydraulic pump regulation and control	2 circuit Liebherr-Synchron-Comfort-system (LSC) with electronic engine speed sensing regulation, pressure and flow compensation, automatic oil flow optimizer
Hydraulic tank	90 gal
Hydraulic system	251 gal
Filtration	2 main return filters with integrated partial micro filtration (5 µm)
MODE selection	Adjustment of engine and hydraulic performance via a mode pre-selector to match application, e.g. for especially economical and environmentally friendly operation or for maximum material handling and heavy-duty jobs
S (Sensitive)	Mode for precision work and lifting through very sensitive movements
E (Eco)	Mode for especially economical and environmentally friendly operation
P (Power)	Mode for high performance with low fuel consumption
P+ (Power-Plus)	Mode for highest performance and for very heavy duty applications, suitable for continuous operation
Engine speed and performance setting	Stepless alignment of engine output and hydraulic power via engine speed
Option	Tool Control: 20 pre-adjustable pump flows and pressures for add-on attachments

Swing drive

Drive	Liebherr axial piston motor in a closed system, Liebherr planetary reduction gear
Swing ring	Liebherr, sealed race ball bearing swing ring, internal teeth
Swing speed	0-6.5 rpm stepless
Swing torque	103,996 lbf ft
Holding brake	Wet multi-disc (spring applied, pressure released)
Option	Slewing gear brake Comfort

Cab

Cab	Safety cab structure with individual windscreens or featuring a slide-in subpart under the ceiling, work headlights integrated in the ceiling, a door with a sliding window (can be opened on both sides), large stowing and depositing possibilities, shock-absorbing suspension, sound damping insulating, tinted laminated safety glass, separate shades for the sunroof window and windscreen
High Rise / Gantry	Deviating from standard: safety cab structure with fixed built-in front and roof window made from impact-resistant laminated safety glass
Operator's seat Comfort	Air cushioned operator's seat with 3D-adjustable armrests, headrest, lap belt, seat heater, adjustable seat cushion inclination and length, lockable horizontal suspension, automatic weight adjustment, adjustable suspension stiffness, pneumatic lumbar vertebrae support and passive seat climatization with active coal
Operator's seat Premium (Option)	In addition to operator's seat comfort: active electronic weight adjustment (automatic readjustment), pneumatic low frequency suspension and active seat climatization with active coal and ventilator
Arm consoles	Joysticks with control consoles and swivel seat, folding left control console
Operation and displays	Large high-resolution operating unit, self-explanatory, color display with touchscreen, video-compatible, numerous setting, control and monitoring options, e.g. air conditioning control, fuel consumption respectively energy consumption, machine and attachment parameters
Air-conditioning	
Diesel engine	Automatic air-conditioning, recirculated air function, fast de-icing and demisting at the press of a button, air vents can be operated via a menu; recirculated air and fresh air filters can be easily replaced and are accessible from the outside; heating-cooling unit, designed for extreme outside temperatures, sensors for solar radiation, inside and outside temperatures
Electric motor	In addition to diesel engine: stationary air conditioning function with external climate condenser – controlled by a weekly timer

Equipment

Type	High-strength steel plates at highly-stressed points for the toughest requirements. Complex and stable mountings of equipment and cylinders
Hydraulic cylinders	Liebherr cylinders with special sealing and guide system and, depending on cylinder type, shock absorption
Energy recovering cylinder	Liebherr gas cylinder with special sealing and control system
Bearings	Sealed, low maintenance

WARNING

Breathing diesel engine exhaust exposes you to chemicals known to the State of California to cause cancer and birth defects or other reproductive harm.

- Always start and operate the engine in a well-ventilated area.
- If in an enclosed area, vent the exhaust to the outside.
- Do not modify or tamper with exhaust system.
- Do not idle the engine except as necessary.

For more information go to www.P65warnings.ca.gov/diesel.

Undercarriage

Mobile	
Versions	Standard, High Rise
Drive Standard	One axle drive per drive axle with Liebherr axial piston motor and functional brake valve on both sides
Drive High Rise	One driven axle with transmission with Liebherr axial piston motor and functional brake valve on both sides
Travel speed	0-6.2 mph stepless
Joystick steering	0-2.2 mph stepless (creeper speed) (Diesel) 0-1.9 mph stepless (creeper speed) (Electric) 0-5.0 mph stepless (High Rise) 0-3.1 mph stepless (creeper speed) (High Rise) (Diesel) 0-1.6 mph stepless (creeper speed) (High Rise) (Electric)
Driving operation	Automotive driving using accelerator pedal, cruise control function: storage of variable accelerator pedal positions
Axles	198,400 lb drive axles; manual or automatic hydraulically controlled front axle oscillation lock
Service brake	Two circuit travel brake system with accumulator; wet and backlash-free disc brake
Holding brake	Wet multi-disc (spring applied, pressure released)
Stabilization	4 point outriggers
Crawler	
Versions	EW, SW, High Rise, Gantry
Drive	Liebherr compact planetary reduction gear with Liebherr axial piston motor per side of undercarriage
Travel speed	
EW	0-2.5 mph stepless 0-1.7 mph stepless (creeper speed)
SW	0-2.5 mph stepless 0-1.6 mph stepless (creeper speed)
High Rise	0-1.8 mph stepless 0-1.2 mph stepless (creeper speed)
Gantry	0-2.2 mph stepless 0-1.6 mph stepless (creeper speed)
Brake	Functional brake valves on both sides
Holding brake	Wet multi-disc (spring applied, pressure released)
Track pads	Triple grouser, flat
Tracks	Sealed and greased

Complete machine

Lubrication	Liebherr central lubrication system for uppercarriage and equipment, automatically
Mobile (Option)	Liebherr central lubrication system for undercarriage, automatically
Steps system	Safe and durable access system with anti-slip steps; main components hot-galvanized
Noise emission	
ISO 6396	70 dB(A) = L _{PA} (inside cab)
2000/14/EC	105 dB(A) = L _{WA} (surround noise)

WARNING

This product can expose you to chemicals including lead and lead compounds, which are known to the State of California to cause cancer and birth defects or other reproductive harm.

For more information go to www.P65warnings.ca.gov.

LH 80 M – Dimensions

Industry

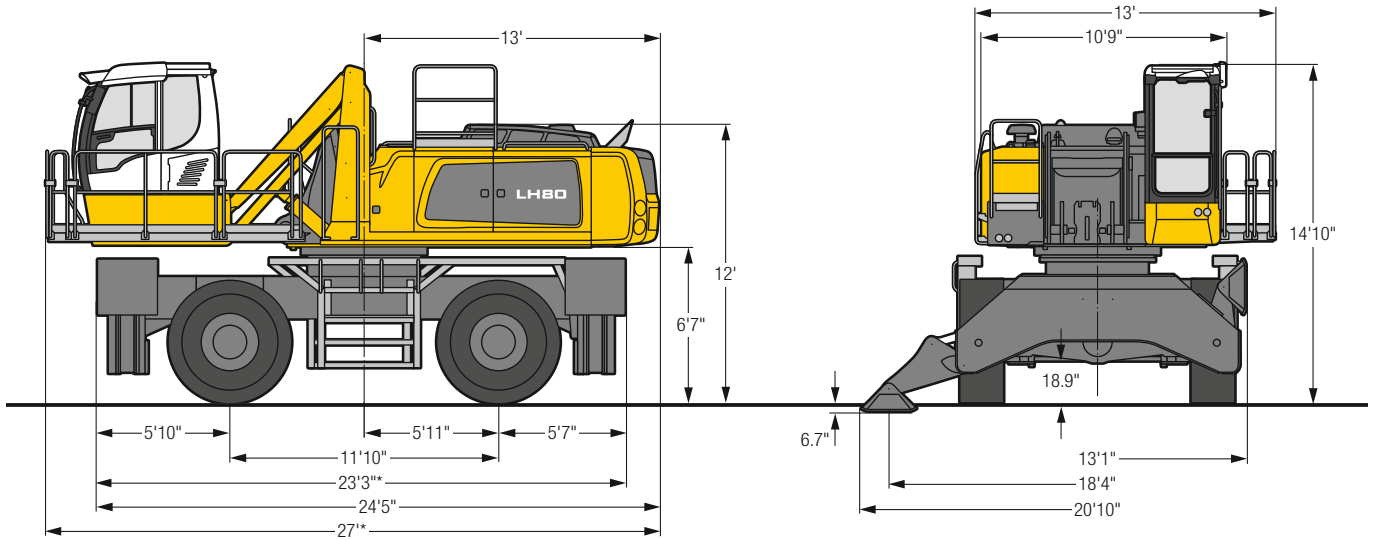

* For electric machines, the length of the machine is increased accordingly by the trailing cable / cable reel system. Detailed dimensions are available on request.

LH 80 M – Choice of cab elevation

Cab elevation LFC (rigid elevation)

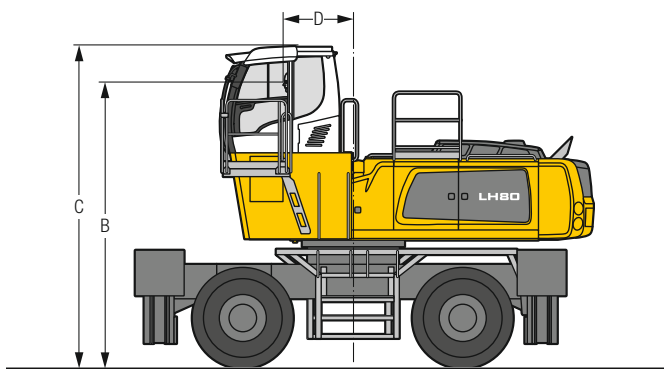

Increase type	LFC 120	LFC 200
Height	3'11"	6'7"
B	15' 5"	18'1"
C	17' 1"	19'9"
D	3' 8"	3'8"

A rigid cab elevation has a fixed eye level height. For a lower transport height, the shell of the cab can be removed and replaced by a transport device. The dimension C is in this machine design for all rigid cab elevations 13'.

Tires 23.5-25

Cab elevation LHC (hydraulic elevation)

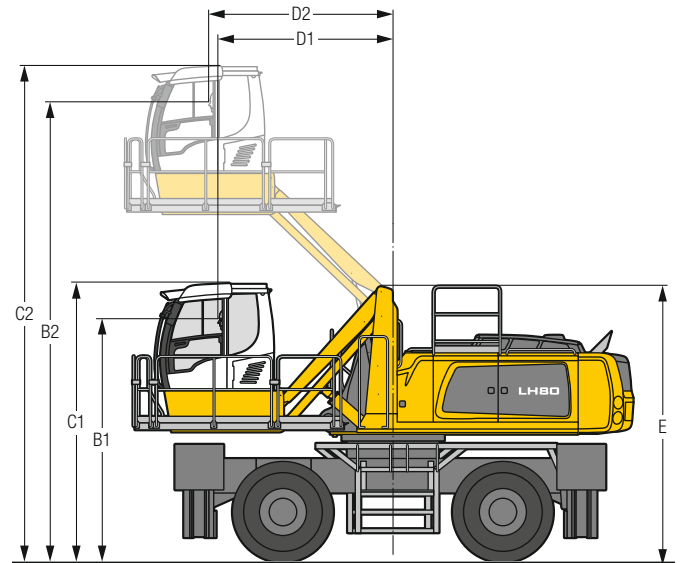

Increase type	LHC 255	LHC 340-35	LHC 360-50
B1	11' 6"	12' 8"	13' 2"
B2	19'10"	23'10"	24'10"
C1	13' 2"	14' 4"	14'10"
C2	21' 6"	25' 6"	26' 6"
D1	5' 6"	9' 2"	9' 4"
D2	5'11"	9' 2"	9'10"
E	12'10"	14' 2"	14' 7"

The hydraulically adjustable cab allows the driver, that he can choose his field of view freely and at any time within the stroke.

LH 80 C EW / SW – Dimensions

Industry

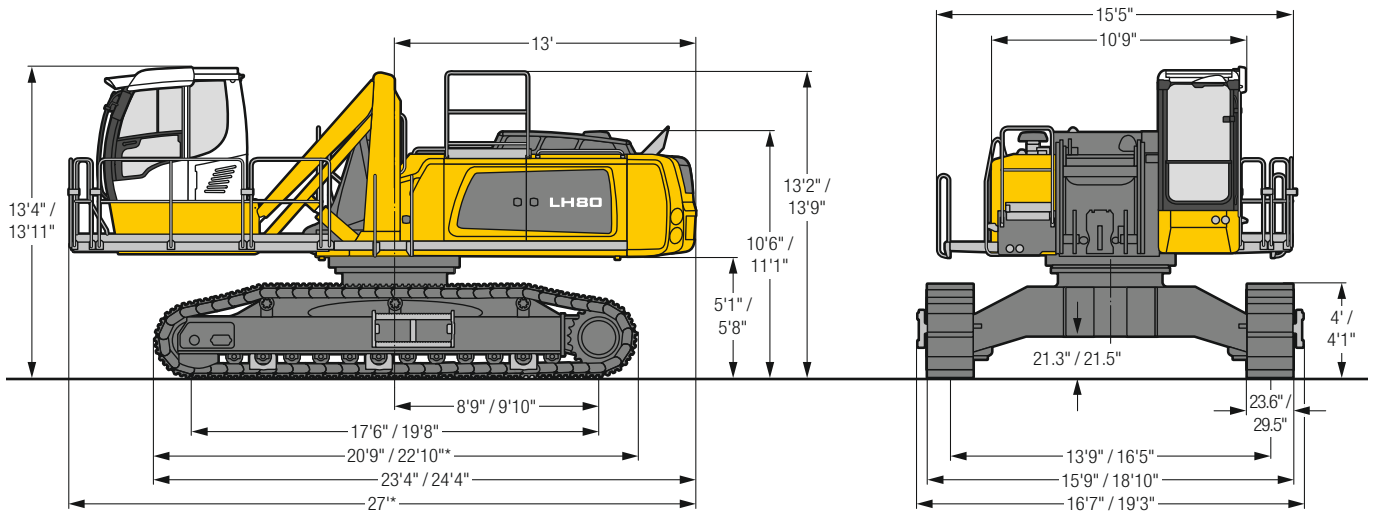

* For electric machines, the length of the machine is increased accordingly by the trailing cable / cable reel system. Detailed dimensions are available on request.

LH 80 C EW / SW – Choice of cab elevation

**Cab elevation LFC
(rigid elevation)**

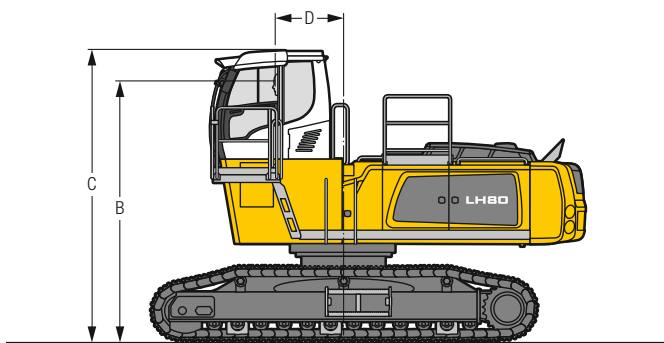

Increase type	LFC 120	LFC 200
Height	3'11"	6' 7"
B	13'11" / 14' 6"	16'6" / 17' 1"
C	15' 7" / 16' 2"	18'3" / 18'10"
D	3' 8"	3' 8"

A rigid cab elevation has a fixed eye level height. For a lower transport height, the shell of the cab can be removed and replaced by a transport device. The dimension C is in this machine design for all rigid cab elevations 12'8".

**Cab elevation LHC
(hydraulic elevation)**

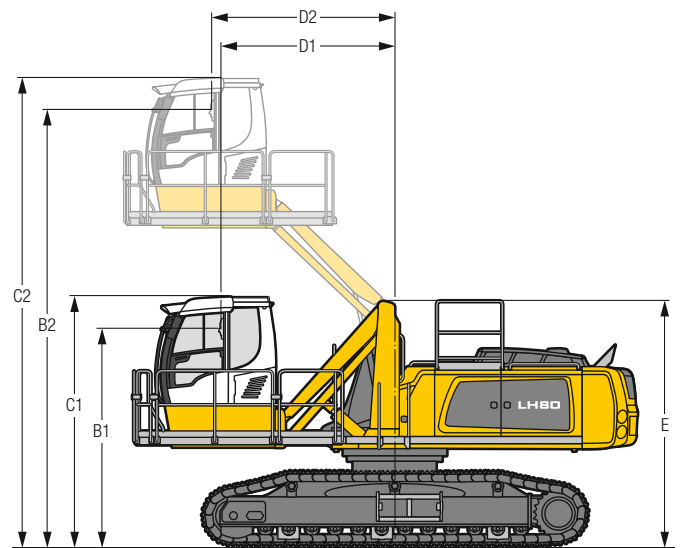

Increase type	LHC 255	LHC 340-35	LHC 360-50
B1	10' / 10' 7"	11' 2" / 11' 9"	11'7" / 12' 2"
B2	18'4" / 18'11"	22' 4" / 22'11"	23'4" / 23'11"
C1	11'8" / 12' 3"	12'10" / 13' 5"	13'4" / 13'11"
C2	20' / 20' 7"	24' / 24' 7"	25' / 25' 7"
D1	5' 6"	9' 2"	9' 4"
D2	5'11"	9' 2"	9'10"
E	11'4" / 11'11"	12' 7" / 13' 2"	13'1" / 13' 8"

The hydraulically adjustable cab allows the driver, that he can choose his field of view freely and at any time within the stroke.

LH 80 M HR – Dimensions

Industry

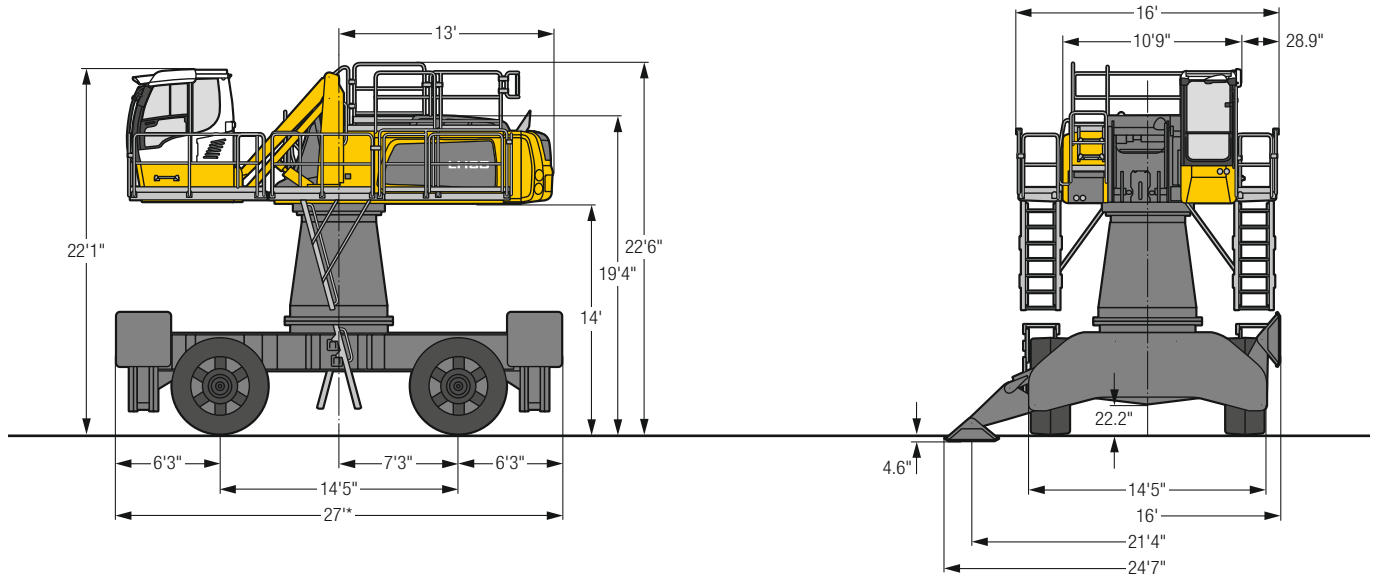

* For electric machines, the length of the machine is increased accordingly by the trailing cable / cable reel system. Detailed dimensions are available on request.

LH 80 M HR – Cab elevation

Cab elevation LHC (hydraulic elevation)

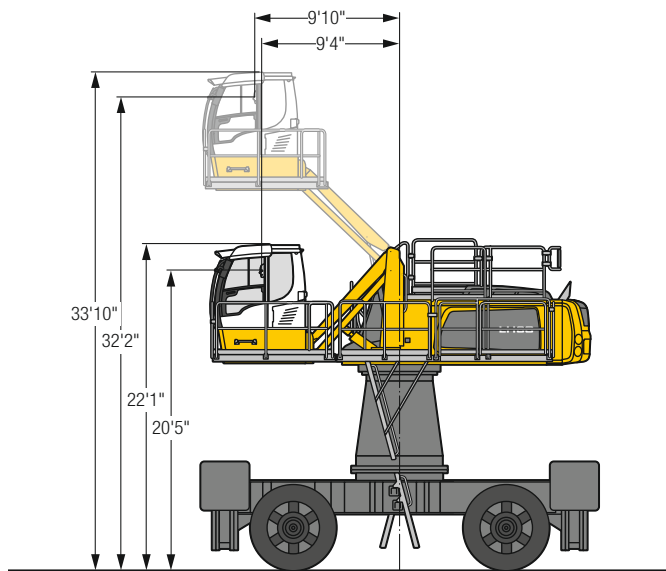

Increase type **LHC 360-50**

The hydraulically adjustable cab allows the driver, that he can choose his field of view freely and at any time within the stroke.

Tires 26.5-25

LH 80 C HR – Dimensions

Industry

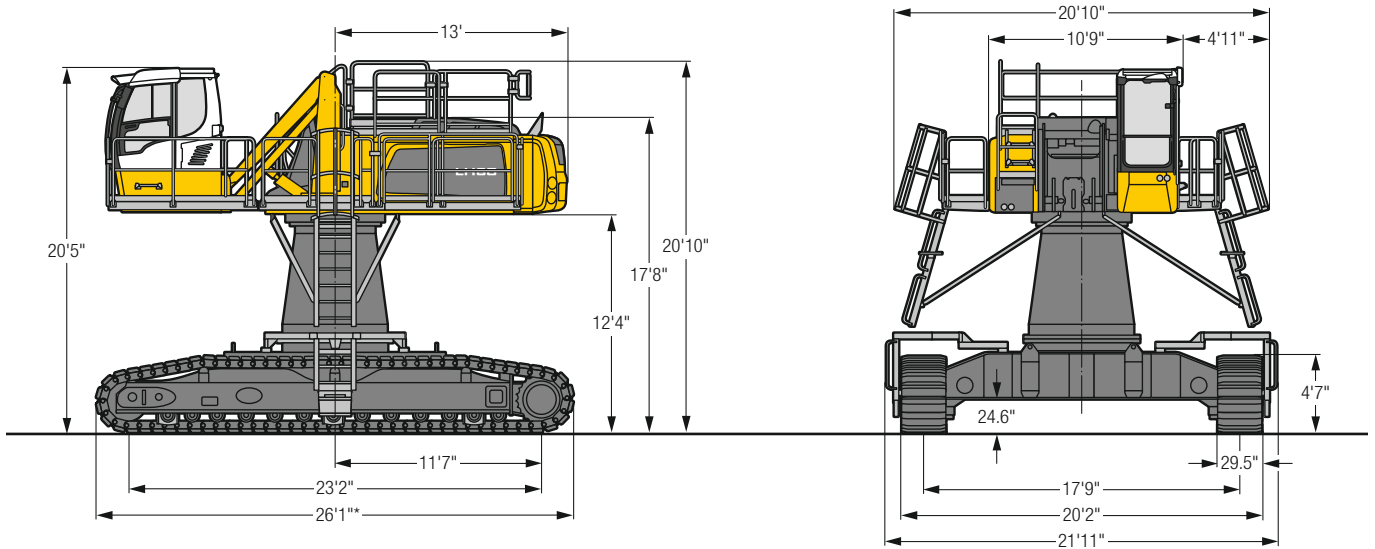

* For electric machines, the length of the machine is increased accordingly by the trailing cable / cable reel system. Detailed dimensions are available on request.

LH 80 C HR – Choice of cab elevation

Cab elevation LHC (hydraulic elevation)

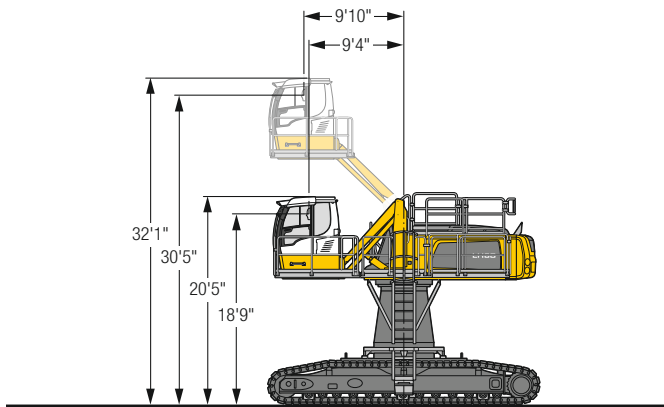

Increase type

LHC 360-50

The hydraulically adjustable cab allows the driver, that he can choose his field of view freely and at any time within the stroke.

Cab elevation LHC-D (hydraulic elevation)

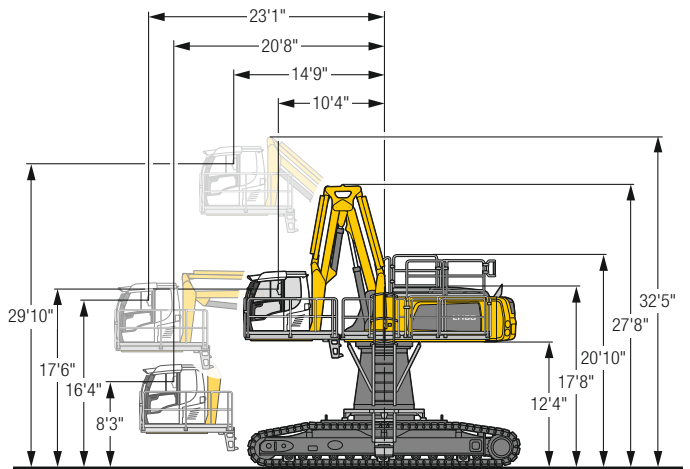

Increase type

LHC-D 730

The hydraulically adjustable cab allows the driver, that he can choose his field of view freely and at any time within the stroke.

LH 80 C Gantry – Dimensions

Industry

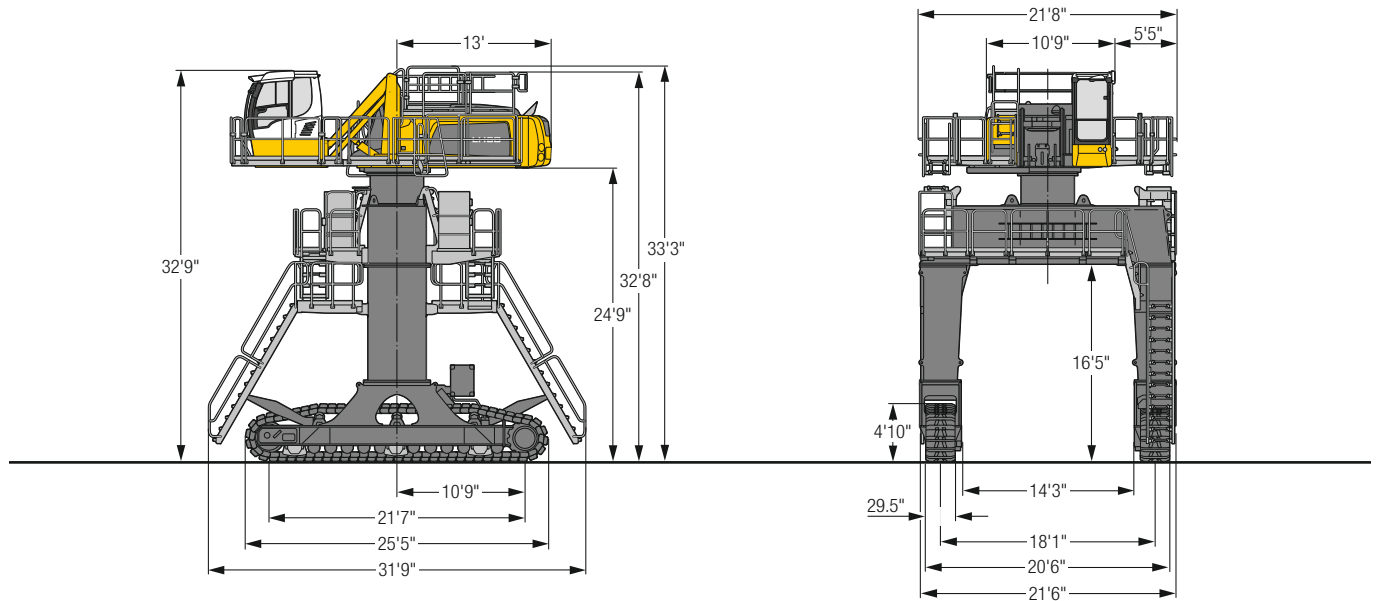

LH 80 C Gantry – Cab elevation

**Cab elevation LHC
(hydraulic elevation)**

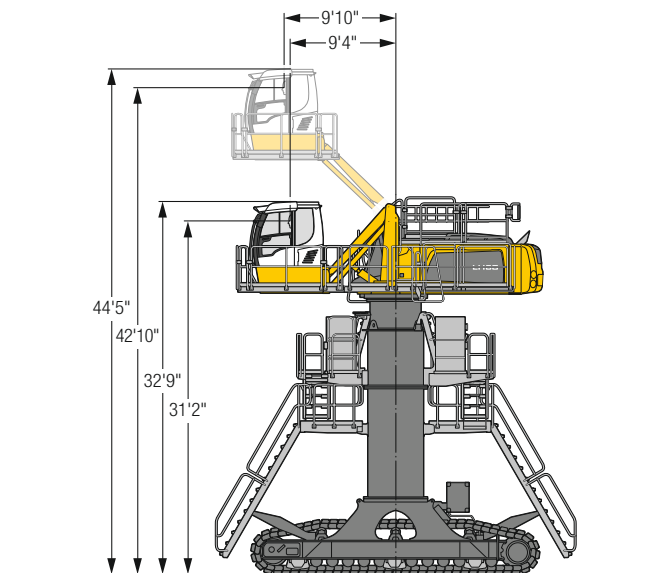

Increase type LHC 360-50

The hydraulically adjustable cab allows the driver, that he can choose his field of view freely and at any time within the stroke.

Kinematic variant 2A

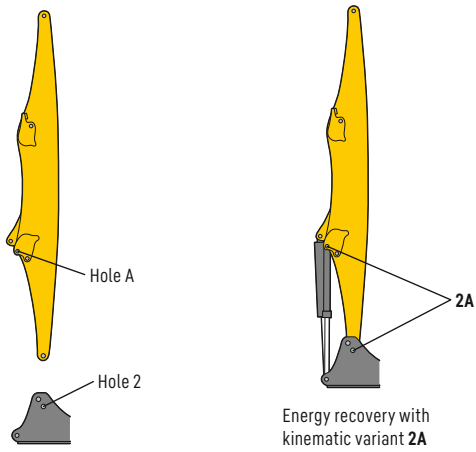

Kinematic variant 2D / 2C

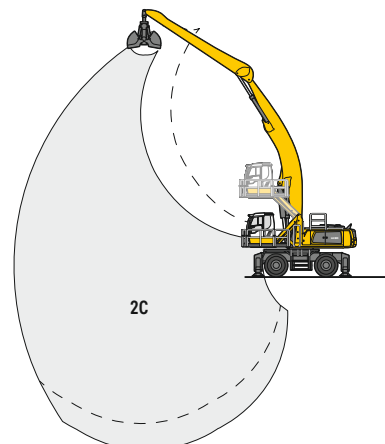
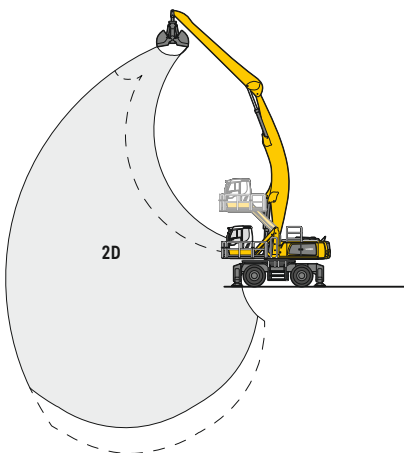
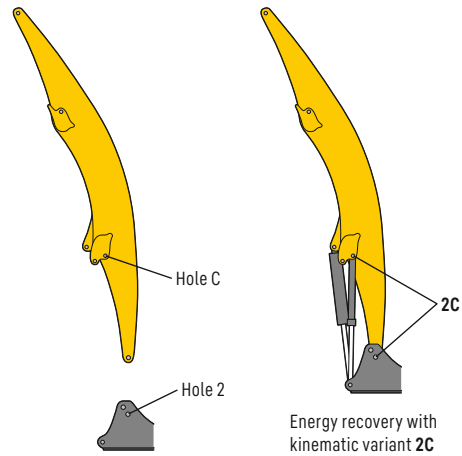
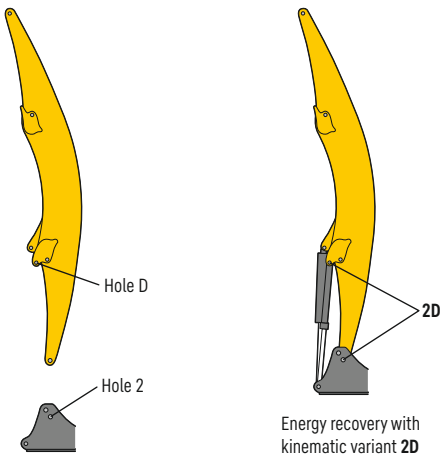

Altered range curve with additional reach depth, e.g. for unloading from ships

LH 80 M – Equipment GA18

Industry – Kinematic 2A

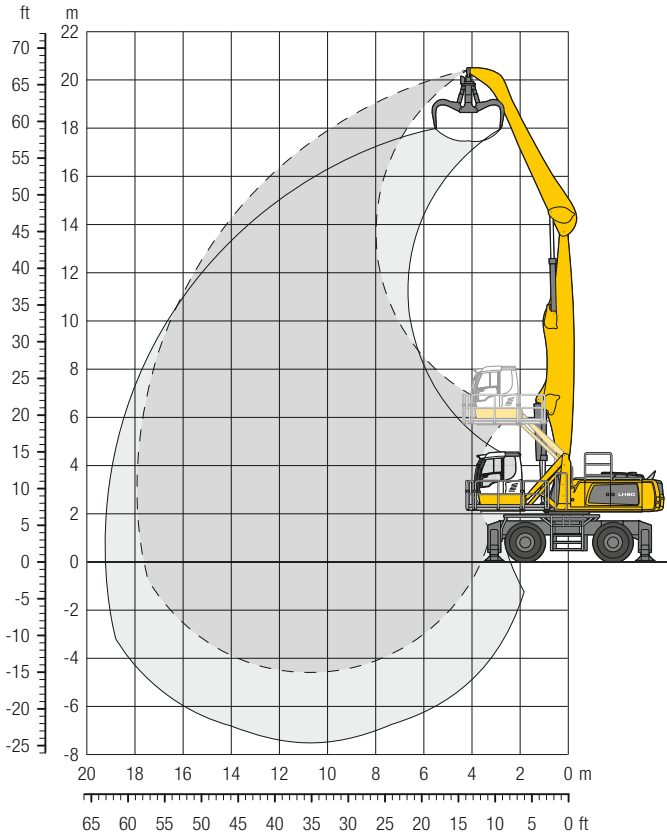

Dimensions

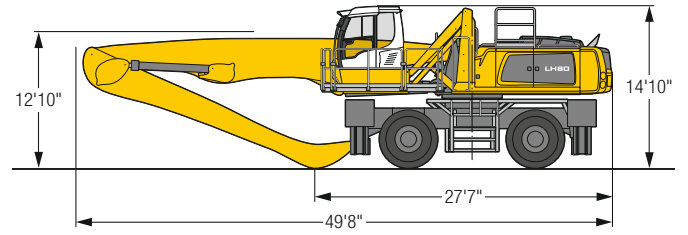

Operating weight

The operating weight includes the basic machine with 4 point outriggers, hydr. cab elevation, 4 solid tires, straight boom 34'5", angled stick 25'7" and multi-tine grab GMM 80-5/2.22 yd³ semi-closed tines.

Weight 167,100 lb

ft	Undercarriage	20 ft		25 ft		30 ft		35 ft		40 ft		45 ft		50 ft		55 ft		60 ft		65 ft		70 ft		ft in			
70	4 pt. outriggers down																										
65	4 pt. outriggers down	31,4*	31,4*																						30,4*	30,4*	20' 8"
60	4 pt. outriggers down			31,6*	31,6*	25,8*	25,8*																		24,0*	24,0*	31'
55	4 pt. outriggers down			34,2*	34,2*	31,0*	31,0*	26,0*	26,0*																21,2*	21,2*	38'
50	4 pt. outriggers down					33,4*	33,4*	30,2*	30,2*	25,2*	25,2*														19,6*	19,6*	43' 4"
45	4 pt. outriggers down					33,4*	33,4*	29,9*	29,9*	27,3*	27,3*	23,4*	23,4*												18,6*	18,6*	47' 5"
40	4 pt. outriggers down					33,5*	33,5*	30,0*	30,0*	27,2*	27,2*	25,1*	25,1*	19,7*	19,7*										17,9*	17,9*	50' 8"
35	4 pt. outriggers down			38,1*	38,1*	34,0*	34,0*	30,3*	30,3*	27,4*	27,4*	25,1*	25,1*	23,2*	23,2*										17,5*	17,5*	53' 5"
30	4 pt. outriggers down			40,4*	40,4*	34,9*	34,9*	30,9*	30,9*	27,8*	27,8*	25,3*	25,3*	23,2*	23,2*	18,5*	18,5*								17,3*	17,3*	55' 5"
25	4 pt. outriggers down	42,6*	42,6*	42,3*	42,3*	36,2*	36,2*	31,8*	31,8*	28,3*	28,3*	25,6*	25,6*	23,4*	23,4*	20,6*	21,2*								17,3*	17,3*	56'11"
20	4 pt. outriggers down	55,2*	55,2*	44,7*	44,7*	37,7*	37,7*	32,7*	32,7*	29,0*	29,0*	26,0*	26,0*	23,5*	23,5*	20,4*	21,2*								17,5*	17,5*	58'
15	4 pt. outriggers down	59,5*	59,5*	47,2*	47,2*	39,2*	39,2*	33,7*	33,7*	29,6*	29,6*	26,3*	26,3*	23,5*	23,6*	20,1*	21,0*								17,7*	17,7*	58' 7"
10	4 pt. outriggers down	50,9*	50,9*	49,2*	49,2*	40,5*	40,5*	34,5*	34,5*	30,0*	30,0*	26,5*	26,5*	23,0*	23,5*	19,8*	20,6*								17,8*	17,8*	58'10"
5	4 pt. outriggers down	24,8*	24,8*	50,2*	50,2*	41,2*	41,2*	34,8*	34,8*	30,1*	30,1*	26,3*	26,3*	22,5*	23,0*	19,5*	19,8*								16,7*	16,7*	58' 6"
0	4 pt. outriggers down	21,0*	21,0*	49,5*	49,5*	40,8*	40,8*	34,5*	34,5*	29,6*	29,6*	25,6*	25,6*	22,1*	22,1*	18,3*	18,3*								15,3*	15,3*	57'10"
-5	4 pt. outriggers down	21,5*	21,5*	41,6*	41,6*	39,0*	39,0*	33,0*	33,0*	28,2*	28,2*	24,2*	24,2*	20,3*	20,3*	15,7*	15,7*								15,0*	15,0*	55' 6"
-10	4 pt. outriggers down			40,3*	40,3*	35,3*	35,3*	30,1*	30,1*	25,7*	25,7*	21,5*	21,5*	17,2*	17,2*										16,8*	16,8*	50' 6"
-15	4 pt. outriggers down					25,4*	25,4*																		24,4*	24,4*	36' 4"

Height Can be slewed through 360° In longitudinal position of undercarriage Max. reach * Limited by hydr. capacity

The lift capacities on the stick end without attachment are stated in lb x 1,000 and are valid on a firm, level supporting surface with blocked oscillating axle. These capacities can be slewed through 360° with the undercarriage in the transverse position. Capacities in the longitudinal position of the undercarriage (±15°) are specified over the rigid axle with the stabilizers down. Indicated loads based on the ISO 10567 standard and do not exceed 75% of tipping or 87% of hydraulic capacity. The lift capacity values indicated are attained at the corresponding operating temperature. This operating temperature is ensured by continuous movement of the boom. Weights of fitted attachments (grabs, load hooks, etc.) and load accommodation attachment are to be deducted from the lift capacity values. The lift capacity of the unit is limited by its stability, the lifting capability of the hydraulic elements, or the maximum permissible lifting capacity of the load hook.

LH 80 M – Equipment GA20

Industry – Kinematic 2A

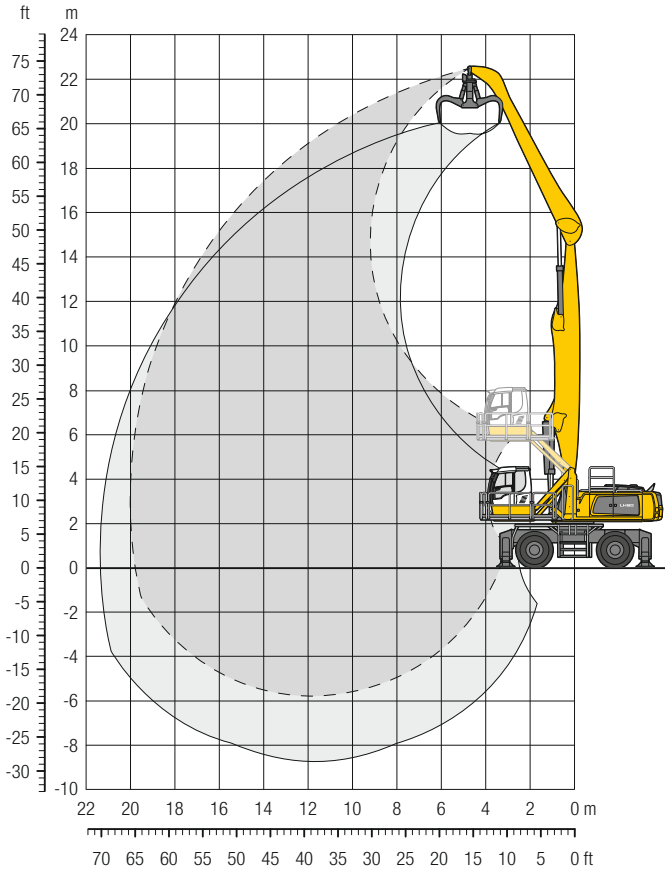

Dimensions

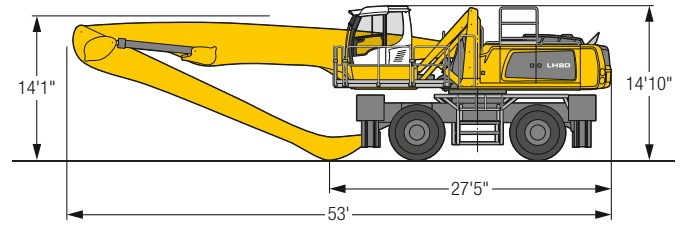

Operating weight

The operating weight includes the basic machine with 4 point outriggers, hydr. cab elevation, 4 solid tires, straight boom 37'9", angled stick 29'6" and multi-tine grab GMM 80-5/2.22 yd³ semi-closed tines.

Weight 169,300 lb

ft	Undercarriage	20 ft	25 ft	30 ft	35 ft	40 ft	45 ft	50 ft	55 ft	60 ft	65 ft	70 ft	ft in
70	4 pt. outriggers down		26,1* 26,1*										23,9* 23,9* 27'
65	4 pt. outriggers down			26,2* 26,2*	21,5* 21,5*								19,9* 19,9* 36' 2"
60	4 pt. outriggers down			28,4* 28,4*	25,7* 25,7*	21,6* 21,6*							17,8* 17,8* 42'11"
55	4 pt. outriggers down			29,6* 29,6*	27,8* 27,8*	25,1* 25,1*	20,9* 20,9*						16,5* 16,5* 48' 2"
50	4 pt. outriggers down				27,8* 27,8*	25,0* 25,0*	22,9* 22,9*	19,4* 19,4*					15,6* 15,6* 52' 5"
45	4 pt. outriggers down				27,7* 27,7*	25,0* 25,0*	22,7* 22,7*	20,9* 20,9*	16,7* 16,7*				15,1* 15,1* 55'11"
40	4 pt. outriggers down			31,6* 31,6*	27,9* 27,9*	25,1* 25,1*	22,8* 22,8*	20,9* 20,9*	19,3* 19,3*				14,7* 14,7* 58' 8"
35	4 pt. outriggers down			32,2* 32,2*	28,3* 28,3*	25,3* 25,3*	22,9* 22,9*	21,0* 21,0*	19,3* 19,3*	16,6* 16,6*			14,5* 14,5* 61'
30	4 pt. outriggers down		33,4* 33,4*	33,0* 33,0*	28,9* 28,9*	25,7* 25,7*	23,2* 23,2*	21,1* 21,1*	19,3* 19,3*	17,6* 17,7*			14,4* 14,4* 62'10"
25	4 pt. outriggers down	33,0* 33,0*	38,5* 38,5*	34,1* 34,1*	29,6* 29,6*	26,2* 26,2*	23,5* 23,5*	21,3* 21,3*	19,4* 19,4*	17,3* 17,7*			14,4* 14,4* 64' 1"
20	4 pt. outriggers down	47,9* 47,9*	42,3* 42,3*	35,4* 35,4*	30,5* 30,5*	26,8* 26,8*	23,9* 23,9*	21,5* 21,5*	19,5* 19,5*	17,1* 17,6*	14,6 14,7*		14,5* 14,5* 65' 1"
15	4 pt. outriggers down	56,1* 56,1*	44,3* 44,3*	36,7* 36,7*	31,3* 31,3*	27,3* 27,3*	24,2* 24,2*	21,7* 21,7*	19,5 19,5*	16,7 17,5*	14,5 15,2*		14,2 14,7* 65' 7"
10	4 pt. outriggers down	39,3* 39,3*	46,0* 46,0*	37,7* 37,7*	32,0* 32,0*	27,7* 27,7*	24,4* 24,4*	21,7* 21,7*	18,9 19,4*	16,4 17,2*	14,3 14,6*		14,0 14,1* 65' 8"
5	4 pt. outriggers down	18,3* 18,3*	46,9* 46,9*	38,3* 38,3*	32,4* 32,4*	27,9* 27,9*	24,4* 24,4*	21,4 21,6*	18,5 19,1*	16,1 16,7*	13,7* 13,7*		13,2* 13,2* 65' 6"
0	4 pt. outriggers down	15,1* 15,1*	34,8* 34,8*	38,2* 38,2*	32,2* 32,2*	27,7* 27,7*	24,1* 24,1*	20,9 21,1*	18,1 18,5*	15,8* 15,8*			12,1* 12,1* 64'11"
-5	4 pt. outriggers down	15,5* 15,5*	29,2* 29,2*	36,9* 36,9*	31,3* 31,3*	26,9* 26,9*	23,3* 23,3*	20,2* 20,2*	17,3* 17,3*	14,2* 14,2*			11,1* 11,1* 63' 7"
-10	4 pt. outriggers down	17,1* 17,1*	28,3* 28,3*	34,2* 34,2*	29,3* 29,3*	25,2* 25,2*	21,7* 21,7*	18,6* 18,6*	15,4* 15,4*				12,0* 12,0* 59' 8"
-15	4 pt. outriggers down		29,2* 29,2*	29,9* 29,9*	26,0* 26,0*	22,4* 22,4*	19,1* 19,1*	16,0* 16,0*					13,7* 13,7* 53' 4"

Height Can be slewed through 360° In longitudinal position of undercarriage Max. reach * Limited by hydr. capacity

The lift capacities on the stick end without attachment are stated in lb x 1,000 and are valid on a firm, level supporting surface with blocked oscillating axle. These capacities can be slewed through 360° with the undercarriage in the transverse position. Capacities in the longitudinal position of the undercarriage (±15°) are specified over the rigid axle with the stabilizers down. Indicated loads based on the ISO 10567 standard and do not exceed 75% of tipping or 87% of hydraulic capacity. The lift capacity values indicated are attained at the corresponding operating temperature. This operating temperature is ensured by continuous movement of the boom. Weights of fitted attachments (grabs, load hooks, etc.) and load accommodation attachment are to be deducted from the lift capacity values. The lift capacity of the unit is limited by its stability, the lifting capability of the hydraulic elements, or the maximum permissible lifting capacity of the load hook.

LH 80 M – Equipment GA21

Industry – Kinematic 2A

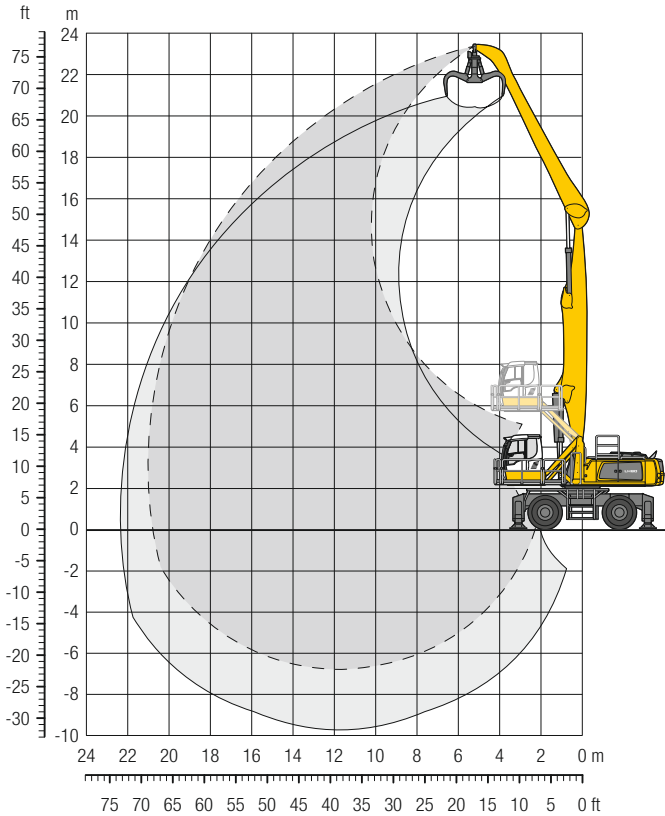

Dimensions

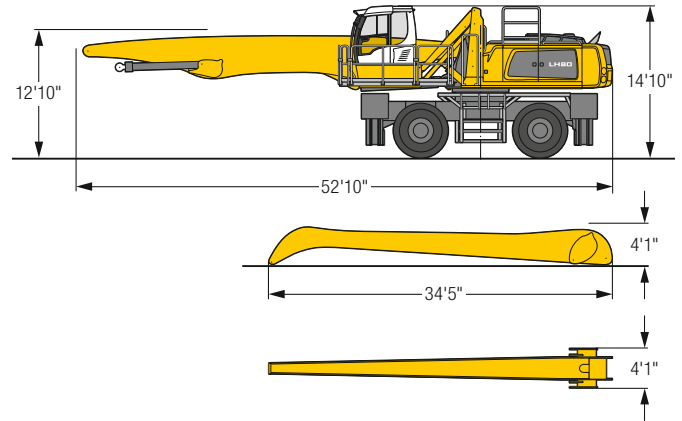

Operating weight

The operating weight includes the basic machine with 4 point outriggers, hydr. cab elevation, 4 solid tires, straight boom 37'9", angled stick 32'10" and multi-tine grab GMM 80-5 / 1.83 yd³ semi-closed tines.

Weight 170,200 lb

ft	Undercarriage	20 ft		25 ft		30 ft		35 ft		40 ft		45 ft		50 ft		55 ft		60 ft		65 ft		70 ft		ft in		
		↔	↕	↔	↕	↔	↕	↔	↕	↔	↕	↔	↕	↔	↕	↔	↕	↔	↕	↔	↕	↔	↕	↔	↕	
75	4 pt. outriggers down	27,2*	27,2*																					24,4*	24,4*	22'11"
70	4 pt. outriggers down					23,0*	23,0*																	19,0*	19,0*	34' 1"
65	4 pt. outriggers down					25,5*	25,5*	22,7*	22,7*	18,7*	18,7*													16,6*	16,6*	41' 8"
60	4 pt. outriggers down							24,7*	24,7*	22,2*	22,2*	18,3*	18,3*											15,1*	15,1*	47' 8"
55	4 pt. outriggers down							25,8*	25,8*	24,1*	24,1*	21,5*	21,5*	17,3*	17,3*									14,2*	14,2*	52' 5"
50	4 pt. outriggers down							26,6*	26,6*	24,0*	24,0*	21,9*	21,9*	20,2*	20,2*	15,5*	15,5*							13,5*	13,5*	56' 4"
45	4 pt. outriggers down							26,6*	26,6*	24,0*	24,0*	21,8*	21,8*	20,1*	20,1*	18,6*	18,6*							13,0*	13,0*	59' 7"
40	4 pt. outriggers down							26,8*	26,8*	24,1*	24,1*	21,9*	21,9*	20,1*	20,1*	18,5*	18,5*	16,3*	16,3*					12,7*	12,7*	62' 2"
35	4 pt. outriggers down							27,2*	27,2*	24,3*	24,3*	22,1*	22,1*	20,2*	20,2*	18,6*	18,6*	17,1*	17,1*					12,5*	12,5*	64' 5"
30	4 pt. outriggers down					29,8*	29,8*	27,7*	27,7*	24,7*	24,7*	22,3*	22,3*	20,3*	20,3*	18,6*	18,6*	17,2*	17,2*	14,6*	14,6*			12,5*	12,5*	66' 1"
25	4 pt. outriggers down			29,5*	29,5*	32,7*	32,7*	28,5*	28,5*	25,2*	25,2*	22,7*	22,7*	20,6*	20,6*	18,8*	18,8*	17,2*	17,2*	15,0	15,6*			12,5*	12,5*	67' 5"
20	4 pt. outriggers down	30,2*	30,2*	36,4*	36,4*	33,9*	33,9*	29,3*	29,3*	25,8*	25,8*	23,0*	23,0*	20,8*	20,8*	18,9*	18,9*	17,2*	17,2*	14,8	15,5*			12,6*	12,6*	68' 4"
15	4 pt. outriggers down	53,2*	53,2*	42,4*	42,4*	35,2*	35,2*	30,2*	30,2*	26,4*	26,4*	23,4*	23,4*	21,0*	21,0*	19,0*	19,0*	16,8	17,2*	14,5	15,4*			12,7*	12,7*	68'10"
10	4 pt. outriggers down	56,4*	56,4*	44,3*	44,3*	36,4*	36,4*	31,0*	31,0*	26,9*	26,9*	23,7*	23,7*	21,2*	21,2*	19,0*	19,0*	16,4	17,0*	14,2	15,0*			12,8	13,0*	68'11"
5	4 pt. outriggers down	28,9*	28,9*	45,6*	45,6*	37,3*	37,3*	31,5*	31,5*	27,2*	27,2*	23,9*	23,9*	21,2*	21,2*	18,5	18,9*	16,0	16,7*	14,0	14,5*			12,2*	12,2*	68' 8"
0	4 pt. outriggers down	18,4*	18,4*	46,0*	46,0*	37,6*	37,6*	31,7*	31,7*	27,3*	27,3*	23,8*	23,8*	20,8	21,0*	18,0	18,5*	15,6	16,2*	13,6*	13,6*			11,3*	11,3*	68' 1"
-5	4 pt. outriggers down	16,6*	16,6*	33,3*	33,3*	37,0*	37,0*	31,3*	31,3*	26,8*	26,8*	23,3*	23,3*	20,2	20,4*	17,5	17,7*	15,1*	15,1*	12,1*	12,1*			10,1*	10,1*	67' 1"
-10	4 pt. outriggers down	17,1*	17,1*	29,6*	29,6*	35,3*	35,3*	29,9*	29,9*	25,7*	25,7*	22,2*	22,2*	19,2*	19,2*	16,4*	16,4*	13,5*	13,5*					10,5*	10,5*	64' 1"
-15	4 pt. outriggers down	18,5*	18,5*	29,1*	29,1*	32,1*	32,1*	27,5*	27,5*	23,7*	23,7*	20,3*	20,3*	17,3*	17,3*	14,3*	14,3*							11,6*	11,6*	59' 1"
-20	4 pt. outriggers down					27,3*	27,3*	23,7*	23,7*	20,4*	20,4*	17,4*	17,4*	14,3*	14,3*									14,0*	14,0*	50' 6"

Height Can be slewed through 360° In longitudinal position of undercarriage Max. reach * Limited by hydr. capacity

The lift capacities on the stick end without attachment are stated in lb x 1,000 and are valid on a firm, level supporting surface with blocked oscillating axle. These capacities can be slewed through 360° with the undercarriage in the transverse position. Capacities in the longitudinal position of the undercarriage (±15°) are specified over the rigid axle with the stabilizers down. Indicated loads based on the ISO 10567 standard and do not exceed 75% of tipping or 87% of hydraulic capacity. The lift capacity values indicated are attained at the corresponding operating temperature. This operating temperature is ensured by continuous movement of the boom. Weights of fitted attachments (grabs, load hooks, etc.) and load accommodation attachment are to be deducted from the lift capacity values. The lift capacity of the unit is limited by its stability, the lifting capability of the hydraulic elements, or the maximum permissible lifting capacity of the load hook.

LH 80 M – Equipment GA22

Industry – Kinematic 2A

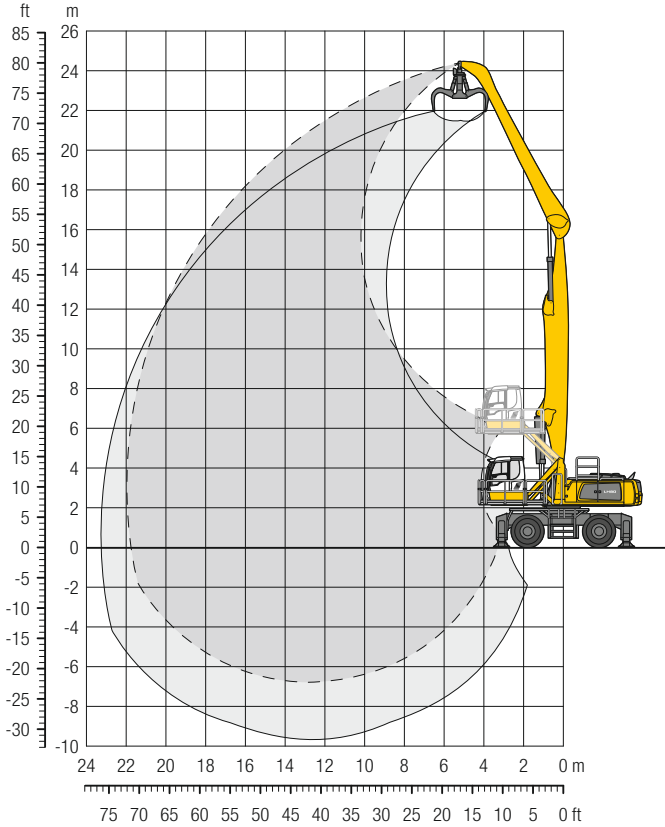

Dimensions

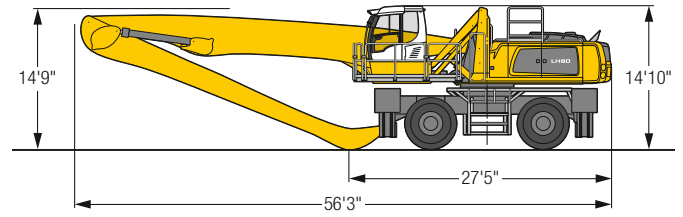

Operating weight

The operating weight includes the basic machine with 4 point outriggers, hydr. cab elevation, 4 solid tires, straight boom 41', angled stick 32'10" and multi-tine grab GMM 80-5 / 1.83 yd³ semi-closed tines.

Weight	172,000 lb
--------	------------

ft	Undercarriage	20 ft	25 ft	30 ft	35 ft	40 ft	45 ft	50 ft	55 ft	60 ft	65 ft	70 ft	ft in
75	4 pt. outriggers down		25,6* 25,6*	21,7* 21,7*									20,4* 20,4* 31' 4"
70	4 pt. outriggers down			25,0* 25,0*	22,0* 22,0*	17,6* 17,6*							17,4* 17,4* 40' 2"
65	4 pt. outriggers down				24,3* 24,3*	21,7* 21,7*	17,8* 17,8*						15,7* 15,7* 46' 11"
60	4 pt. outriggers down				25,6* 25,6*	23,8* 23,8*	21,2* 21,2*	17,2* 17,2*					14,5* 14,5* 52' 2"
55	4 pt. outriggers down				26,4* 26,4*	23,6* 23,6*	21,2* 21,2*	19,3* 19,3*	16,0* 16,0*				13,8* 13,8* 56' 7"
50	4 pt. outriggers down				26,5* 26,5*	23,5* 23,5*	21,1* 21,1*	19,2* 19,2*	17,6* 17,6*	13,6* 13,6*			13,3* 13,3* 60' 2"
45	4 pt. outriggers down				26,5* 26,5*	23,5* 23,5*	21,1* 21,1*	19,2* 19,2*	17,6* 17,6*	16,1* 16,1*			12,9* 12,9* 63' 2"
40	4 pt. outriggers down				26,7* 26,7*	23,7* 23,7*	21,2* 21,2*	19,2* 19,2*	17,6* 17,6*	16,1* 16,1*	14,0* 14,0*		12,6* 12,6* 65' 8"
35	4 pt. outriggers down			29,1* 29,1*	27,1* 27,1*	23,9* 23,9*	21,4* 21,4*	19,3* 19,3*	17,6* 17,6*	16,1* 16,1*	14,7* 14,7*		12,5* 12,5* 67' 10"
30	4 pt. outriggers down			31,4* 31,4*	27,5* 27,5*	24,2* 24,2*	21,6* 21,6*	19,5* 19,5*	17,7* 17,7*	16,1* 16,1*	14,7* 14,7*		12,5* 12,5* 69' 5"
25	4 pt. outriggers down	27,3* 27,3*	32,9* 32,9*	32,7* 32,7*	28,1* 28,1*	24,6* 24,6*	21,8* 21,8*	19,6* 19,6*	17,7* 17,7*	16,1* 16,1*	14,5 14,6*	12,3 13,1*	12,1 12,5* 70' 7"
20	4 pt. outriggers down	40,7* 40,7*	40,5* 40,5*	33,6* 33,6*	28,7* 28,7*	25,0* 25,0*	22,1* 22,1*	19,8* 19,8*	17,8* 17,8*	16,1* 16,1*	14,2 14,6*	12,2 12,9*	11,6 12,3* 71' 6"
15	4 pt. outriggers down	53,3* 53,3*	41,9* 41,9*	34,5* 34,5*	29,2* 29,2*	25,3* 25,3*	22,3* 22,3*	19,9* 19,9*	17,8* 17,8*	16,1* 16,1*	13,8 14,4*	12,0 12,6*	11,3 11,7* 72'
10	4 pt. outriggers down	26,4* 26,4*	43,0* 43,0*	35,2* 35,2*	29,7* 29,7*	25,6* 25,6*	22,5* 22,5*	19,9* 19,9*	17,8* 17,8*	15,6 15,9*	13,5 14,1*	11,7 12,2*	11,1* 11,1* 72' 1"
5	4 pt. outriggers down	12,8* 12,8*	38,5* 38,5*	35,5* 35,5*	29,9* 29,9*	25,7* 25,7*	22,4* 22,4*	19,8* 19,8*	17,5 17,6*	15,1 15,6*	13,2 13,7*	11,5* 11,5*	10,3* 10,3* 71' 11"
0	4 pt. outriggers down	10,8* 10,8*	24,5* 24,5*	35,2* 35,2*	29,6* 29,6*	25,5* 25,5*	22,2* 22,2*	19,5* 19,5*	16,9 17,2*	14,7 15,1*	12,9 13,0*	10,4* 10,4*	9,4* 9,4* 71' 4"
-5	4 pt. outriggers down	11,2* 11,2*	21,1* 21,1*	34,0* 34,0*	28,8* 28,8*	24,8* 24,8*	21,5* 21,5*	18,8* 18,8*	16,4 16,5*	14,2* 14,2*	11,9* 11,9*	8,7* 8,7*	8,4* 8,4* 70' 5"
-10	4 pt. outriggers down	12,6* 12,6*	20,6* 20,6*	31,7* 31,7*	27,2* 27,2*	23,5* 23,5*	20,4* 20,4*	17,7* 17,7*	15,3* 15,3*	12,9* 12,9*	10,2*		8,6* 8,6* 67' 5"
-15	4 pt. outriggers down		21,5* 21,5*	28,2* 28,2*	24,6* 24,6*	21,4* 21,4*	18,5* 18,5*	16,0* 16,0*	13,5* 13,5*	10,9* 10,9*			9,5* 9,5* 62' 5"
-20	4 pt. outriggers down			23,2* 23,2*	20,8* 20,8*	18,2* 18,2*	15,8* 15,8*	13,3* 13,3*					11,5* 11,5* 53' 8"

Height Can be slewed through 360° In longitudinal position of undercarriage Max. reach * Limited by hydr. capacity

The lift capacities on the stick end without attachment are stated in lb x 1,000 and are valid on a firm, level supporting surface with blocked oscillating axle. These capacities can be slewed through 360° with the undercarriage in the transverse position. Capacities in the longitudinal position of the undercarriage (±15°) are specified over the rigid axle with the stabilizers down. Indicated loads based on the ISO 10567 standard and do not exceed 75% of tipping or 87% of hydraulic capacity. The lift capacity values indicated are attained at the corresponding operating temperature. This operating temperature is ensured by continuous movement of the boom. Weights of fitted attachments (grabs, load hooks, etc.) and load accommodation attachment are to be deducted from the lift capacity values. The lift capacity of the unit is limited by its stability, the lifting capability of the hydraulic elements, or the maximum permissible lifting capacity of the load hook.

LH 80 M – Equipment AG21

Industry – Kinematic 2D

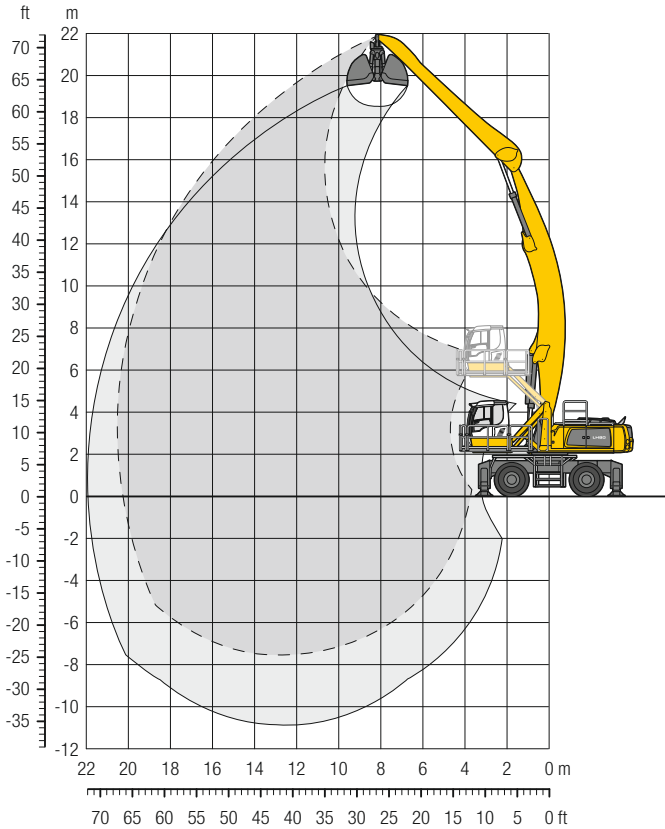

Dimensions

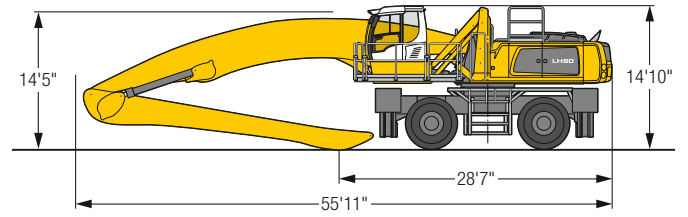

Operating weight

The operating weight includes the basic machine with 4 point outriggers, hydr. cab elevation, 4 solid tires, angled boom 41', straight stick 29'6" and grab for loose material GMZ 80 / 3.92 yd³.

Weight 172,200 lb

ft	Undercarriage	20 ft	25 ft	30 ft	35 ft	40 ft	45 ft	50 ft	55 ft	60 ft	65 ft	70 ft	ft in
70	4 pt. outriggers down			22.0* 22.0*									20.1* 20.1* 32'
65	4 pt. outriggers down				22.6* 22.6*	17.8* 17.8*							17.7* 17.7* 40' 1"
60	4 pt. outriggers down				23.1* 23.1*	20.8* 20.8*	17.9* 17.9*						16.4* 16.4* 46' 2"
55	4 pt. outriggers down				22.8* 22.8*	20.5* 20.5*	18.8* 18.8*	17.1* 17.1*					15.6* 15.6* 51' 1"
50	4 pt. outriggers down					20.5* 20.5*	18.6* 18.6*	17.2* 17.2*	15.2* 15.2*				15.0* 15.0* 55' 1"
45	4 pt. outriggers down				22.9* 22.9*	20.5* 20.5*	18.7* 18.7*	17.2* 17.2*	16.0* 16.0*				14.7* 14.7* 58' 5"
40	4 pt. outriggers down				23.2* 23.2*	20.8* 20.8*	18.8* 18.8*	17.3* 17.3*	16.0* 16.0*	15.0* 15.0*			14.5* 14.5* 61' 1"
35	4 pt. outriggers down				23.7* 23.7*	21.1* 21.1*	19.1* 19.1*	17.4* 17.4*	16.1* 16.1*	15.0* 15.0*			14.4* 14.4* 63' 4"
30	4 pt. outriggers down			28.0* 28.0*	24.3* 24.3*	21.6* 21.6*	19.4* 19.4*	17.7* 17.7*	16.3* 16.3*	15.1* 15.1*	14.1* 14.1*		14.1* 14.1* 65'
25	4 pt. outriggers down	42.9* 42.9*	34.6* 34.6*	29.1* 29.1*	25.1* 25.1*	22.1* 22.1*	19.8* 19.8*	18.0* 18.0*	16.5* 16.5*	15.2* 15.2*	14.2* 14.2*		13.9* 13.9* 66' 5"
20	4 pt. outriggers down	46.1* 46.1*	36.5* 36.5*	30.3* 30.3*	26.0* 26.0*	22.8* 22.8*	20.3* 20.3*	18.3* 18.3*	16.7* 16.7*	15.4* 15.4*	14.2* 14.2*		13.3 13.7* 67' 4"
15	4 pt. outriggers down	49.4* 49.4*	38.5* 38.5*	31.6* 31.6*	26.9* 26.9*	23.4* 23.4*	20.8* 20.8*	18.7* 18.7*	17.0* 17.0*	15.5* 15.5*	14.0 14.3*		12.9 13.6* 67'10"
10	4 pt. outriggers down	16.8* 16.8*	40.4* 40.4*	32.9* 32.9*	27.8* 27.8*	24.1* 24.1*	21.2* 21.2*	19.0* 19.0*	17.2* 17.2*	15.7* 15.7*	13.7 14.3*		12.6 13.4* 67'11"
5	4 pt. outriggers down	11.7* 11.7*	29.1* 29.1*	33.9* 33.9*	28.5* 28.5*	24.6* 24.6*	21.6* 21.6*	19.3* 19.3*	17.4* 17.4*	15.4 15.7*	13.4 14.2*		12.5 13.3* 67' 8"
0	4 pt. outriggers down	11.3* 11.3*	22.7* 22.7*	34.5* 34.5*	29.0* 29.0*	25.0* 25.0*	21.9* 21.9*	19.4* 19.4*	17.3 17.4*	15.0 15.6*	13.2 13.9*		12.5 13.1* 67' 1"
- 5	4 pt. outriggers down	12.5* 12.5*	21.2* 21.2*	34.5* 34.5*	29.1* 29.1*	25.1* 25.1*	21.9* 21.9*	19.4 19.4*	16.8 17.2*	14.7 15.3*	13.0 13.3*		12.7 12.8* 66' 1"
-10	4 pt. outriggers down	14.2* 14.2*	21.6* 21.6*	33.7* 33.7*	28.7* 28.7*	24.7* 24.7*	21.6* 21.6*	18.9 19.0*	16.5 16.8*	14.5 14.7*			12.4* 12.4* 64' 8"
-15	4 pt. outriggers down	16.2* 16.2*	22.8* 22.8*	32.0* 32.0*	27.5* 27.5*	23.8* 23.8*	20.8* 20.8*	18.2* 18.2*	15.9* 15.9*	13.4* 13.4*			11.7* 11.7* 62'11"
-20	4 pt. outriggers down			29.3* 29.3*	25.5* 25.5*	22.2* 22.2*	19.4* 19.4*	16.8* 16.8*	14.2* 14.2*				12.8* 12.8* 57' 6"
-25	4 pt. outriggers down												

Height Can be slewed through 360° In longitudinal position of undercarriage Max. reach * Limited by hydr. capacity

The lift capacities on the stick end without attachment are stated in lb x 1,000 and are valid on a firm, level supporting surface with blocked oscillating axle. These capacities can be slewed through 360° with the undercarriage in the transverse position. Capacities in the longitudinal position of the undercarriage (±15°) are specified over the rigid axle with the stabilizers down. Indicated loads based on the ISO 10567 standard and do not exceed 75% of tipping or 87% of hydraulic capacity. The lift capacity values indicated are attained at the corresponding operating temperature. This operating temperature is ensured by continuous movement of the boom. Weights of fitted attachments (grabs, load hooks, etc.) and load accommodation attachment are to be deducted from the lift capacity values. The lift capacity of the unit is limited by its stability, the lifting capability of the hydraulic elements, or the maximum permissible lifting capacity of the load hook.

LH 80 M – Equipment AG22

Industry – Kinematic 2D

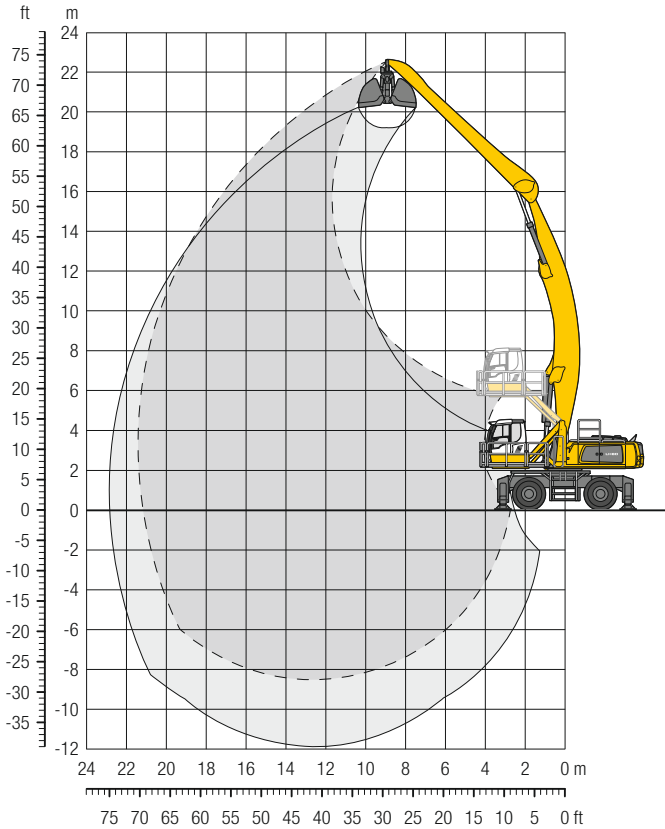

Dimensions

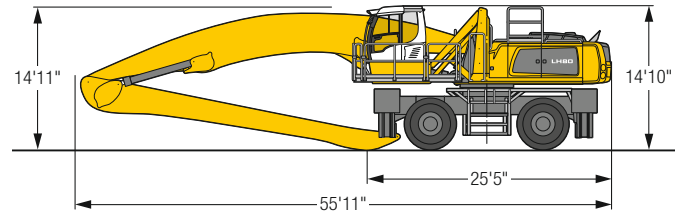

Operating weight

The operating weight includes the basic machine with 4 point outriggers, hydr. cab elevation, 4 solid tires, angled boom 41', straight stick 32'10" and grab for loose material GMZ 80 / 3.92 yd³.

Weight	173,100 lb
--------	------------

ft	Undercarriage	20 ft	25 ft	30 ft	35 ft	40 ft	45 ft	50 ft	55 ft	60 ft	65 ft	70 ft	ft in
70	4 pt. outriggers down				17,9*	17,9*							16,4* 16,4* 36'10"
65	4 pt. outriggers down					18,3* 18,3*							14,8* 14,8* 44'
60	4 pt. outriggers down					19,8* 19,8*	18,0* 18,0*						13,9* 13,9* 49' 8"
55	4 pt. outriggers down					19,6* 19,6*	17,8* 17,8*	16,4* 16,4*					13,3* 13,3* 54' 2"
50	4 pt. outriggers down					19,5* 19,5*	17,7* 17,7*	16,3* 16,3*	15,2* 15,2*				12,8* 12,8* 58'
45	4 pt. outriggers down					19,6* 19,6*	17,8* 17,8*	16,3* 16,3*	15,1* 15,1*	14,1* 14,1*			12,6* 12,6* 61' 2"
40	4 pt. outriggers down					19,8* 19,8*	17,9* 17,9*	16,4* 16,4*	15,1* 15,1*	14,1* 14,1*			12,5* 12,5* 63'10"
35	4 pt. outriggers down				22,5* 22,5*	20,1* 20,1*	18,1* 18,1*	16,5* 16,5*	15,2* 15,2*	14,2* 14,2*	13,3* 13,3*		12,4* 12,4* 65'11"
30	4 pt. outriggers down				23,1* 23,1*	20,5* 20,5*	18,4* 18,4*	16,8* 16,8*	15,4* 15,4*	14,3* 14,3*	13,3* 13,3*		12,5* 12,5* 67' 6"
25	4 pt. outriggers down			27,5* 27,5*	23,8* 23,8*	21,0* 21,0*	18,8* 18,8*	17,0* 17,0*	15,6* 15,6*	14,4* 14,4*	13,4* 13,4*		12,6* 12,6* 68'10"
20	4 pt. outriggers down	43,1* 43,1*	34,4* 34,4*	28,7* 28,7*	24,6* 24,6*	21,6* 21,6*	19,2* 19,2*	17,4* 17,4*	15,8* 15,8*	14,6* 14,6*	13,5* 13,5*		12,4 12,6* 69' 8"
15	4 pt. outriggers down	46,2* 46,2*	36,4* 36,4*	30,0* 30,0*	25,5* 25,5*	22,2* 22,2*	19,7* 19,7*	17,7* 17,7*	16,1* 16,1*	14,7* 14,7*	13,6* 13,6*	12,1 12,5*	12,0 12,5* 70' 2"
10	4 pt. outriggers down	37,7* 37,7*	38,2* 38,2*	31,2* 31,2*	26,4* 26,4*	22,9* 22,9*	20,2* 20,2*	18,1* 18,1*	16,3* 16,3*	14,9* 14,9*	13,7* 13,7*	11,8 12,5*	11,7 12,4* 70' 4"
5	4 pt. outriggers down	18,4* 18,4*	39,8* 39,8*	32,3* 32,3*	27,2* 27,2*	23,5* 23,5*	20,6* 20,6*	18,4* 18,4*	16,6* 16,6*	15,0* 15,0*	13,3 13,7*	11,6 12,3*	11,5 12,3* 70' 1"
0	4 pt. outriggers down	14,7* 14,7*	29,5* 29,5*	33,1* 33,1*	27,8* 27,8*	23,9* 23,9*	21,0* 21,0*	18,6* 18,6*	16,7* 16,7*	14,8 15,1*	12,9 13,6*		11,5 12,2* 69' 6"
-5	4 pt. outriggers down	14,3* 14,3*	24,6* 24,6*	33,5* 33,5*	28,2* 28,2*	24,2* 24,2*	21,1* 21,1*	18,7* 18,7*	16,5 16,7*	14,4 14,9*	12,6 13,3*		11,6 12,0* 68' 6"
-10	4 pt. outriggers down	15,0* 15,0*	23,2* 23,2*	33,2* 33,2*	28,1* 28,1*	24,1* 24,1*	21,0* 21,0*	18,5 18,5*	16,1 16,4*	14,1 14,6*	12,5 12,7*		11,7* 11,7* 67' 2"
-15	4 pt. outriggers down	16,2* 16,2*	23,2* 23,2*	32,2* 32,2*	27,4* 27,4*	23,6* 23,6*	20,6* 20,6*	18,1* 18,1*	15,8 15,9*	13,8* 13,8*	11,5* 11,5*		11,3* 11,3* 65' 5"
-20	4 pt. outriggers down	17,7* 17,7*	24,1* 24,1*	30,2* 30,2*	26,0* 26,0*	22,5* 22,5*	19,6* 19,6*	17,1* 17,1*	14,8* 14,8*	12,4* 12,4*			10,8* 10,8* 62'11"
-25	4 pt. outriggers down			27,1* 27,1*	23,6* 23,6*	20,5* 20,5*	17,8* 17,8*	15,3* 15,3*	12,9* 12,9*				12,8* 12,8* 55' 2"

Height Can be slewed through 360° In longitudinal position of undercarriage Max. reach * Limited by hydr. capacity

The lift capacities on the stick end without attachment are stated in lb x 1,000 and are valid on a firm, level supporting surface with blocked oscillating axle. These capacities can be slewed through 360° with the undercarriage in the transverse position. Capacities in the longitudinal position of the undercarriage (±15°) are specified over the rigid axle with the stabilizers down. Indicated loads based on the ISO 10567 standard and do not exceed 75% of tipping or 87% of hydraulic capacity. The lift capacity values indicated are attained at the corresponding operating temperature. This operating temperature is ensured by continuous movement of the boom. Weights of fitted attachments (grabs, load hooks, etc.) and load accommodation attachment are to be deducted from the lift capacity values. The lift capacity of the unit is limited by its stability, the lifting capability of the hydraulic elements, or the maximum permissible lifting capacity of the load hook.

LH 80 C EW – Equipment GA18

Industry – Kinematic 2A

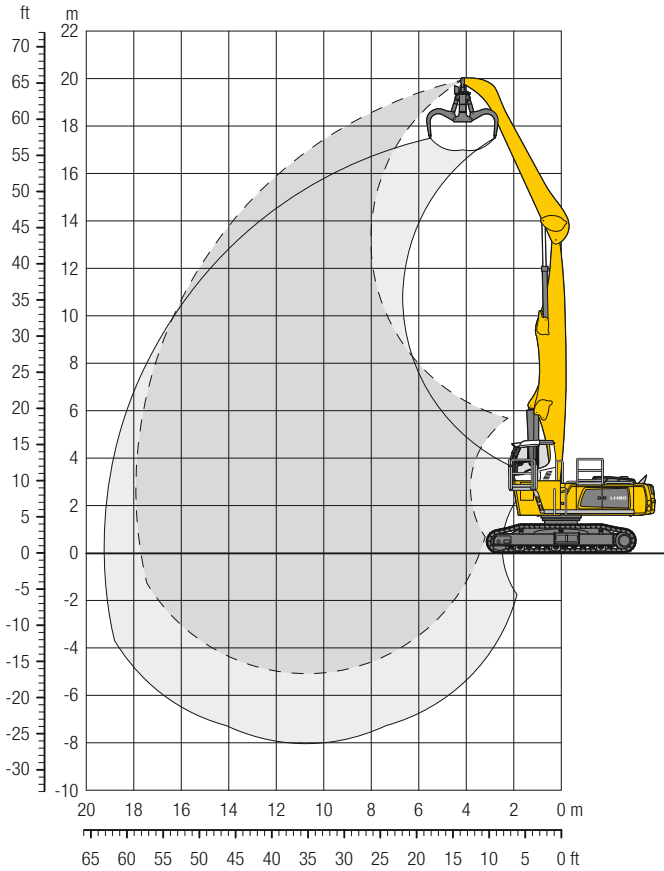

Dimensions

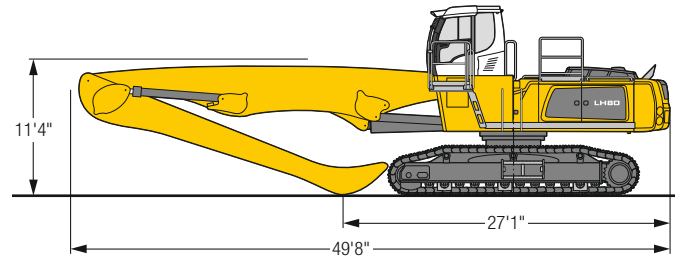

Operating weight and ground pressure

The operating weight includes the basic machine with rigid cab elevation, straight boom 34'5", angled stick 25'7" and multi-tine grab GMM 80-5 / 2.22 yd³ semi-closed tines.

Weight	149,900 lb
Pad width	24"
Ground pressure	on request

ft	Undercarriage	20 ft		25 ft		30 ft		35 ft		40 ft		45 ft		50 ft		55 ft		60 ft		65 ft		70 ft		ft in	
		EW	EW	EW	EW	EW	EW	EW	EW	EW	EW	EW	EW	EW	EW	EW	EW	EW	EW	EW	EW	EW	EW	EW	EW
70	EW																								
65	EW																								
60	EW																								
55	EW			29,8*	29,8*																				
50	EW			33,5*	33,5*	29,7*	29,7*	23,6*	23,6*																
45	EW					30,4*	30,4*	27,2*	27,2*	23,1*	23,1*														
40	EW					30,0*	30,0*	26,8*	26,8*	24,4*	24,4*	20,0	21,3*												
35	EW					30,0*	30,0*	26,7*	26,7*	24,2*	24,2*	20,3	22,2*												
30	EW			34,9*	34,9*	30,3*	30,3*	26,9*	26,9*	24,3*	24,3*	20,2	22,2*	16,3	20,5*										
25	EW			35,9*	35,9*	31,0*	31,0*	27,3*	27,3*	24,6*	24,6*	19,9	22,3*	16,2	20,5*										
20	EW	40,0*	40,0*	37,3*	37,3*	31,9*	31,9*	28,0*	28,0*	24,0	25,0*	19,4	22,6*	16,0	20,5	13,2	17,1								
15	EW	48,2*	48,2*	39,2*	39,2*	33,1*	33,1*	28,8*	28,8*	23,1	25,5*	18,8	22,9*	15,6	20,1	13,0	16,9								
10	EW	51,8*	51,8*	41,3*	41,3*	34,4*	34,4*	27,4	29,6*	22,0	26,0*	18,1	23,2*	15,1	19,6	12,7	16,6								
5	EW	55,1*	55,1*	42,9	43,2*	32,6	35,6*	25,8	30,4*	21,0	26,4*	17,4	22,6	14,6	19,1	12,4	16,3								
0	EW	28,8*	28,8*	39,7	44,5*	30,5	36,4*	24,4	30,8*	20,0	26,2	16,7	21,9	14,2	18,6	12,1	16,1								
-5	EW	21,5*	21,5*	37,3	44,4*	28,9	36,5*	23,2	30,8*	19,2	25,4	16,1	21,3	13,8	18,3	11,9	15,8								
-10	EW	21,1*	21,1*	35,9	42,5*	27,7	35,3*	22,4	29,9*	18,6	24,7	15,7	20,9	13,5	18,0	11,8	14,7*								
-15	EW	22,8*	22,8*	35,2	38,5*	27,1	32,6*	21,9	27,8*	18,2	23,6*	15,5	19,9*	13,4	16,2*										
-20	EW					26,9	28,0*	21,7	24,1*	18,0	20,3*														

Height Can be slewed through 360° In longitudinal position of undercarriage Max. reach * Limited by hydr. capacity

The lift capacities on the stick end without attachment are stated in lb x 1,000 and can be slewed through 360° on a firm, level supporting surface. Capacities are valid for 24" wide triple grouser pads (resp. flat pads). Indicated loads based on the ISO 10567 standard and do not exceed 75% of tipping or 87% of hydraulic capacity. The lift capacity values indicated are attained at the corresponding operating temperature. This operating temperature is ensured by continuous movement of the boom. Weights of fitted attachments (grabs, load hooks, etc.) and load accommodation attachment are to be deducted from the lift capacity values. The lift capacity of the unit is limited by its stability, the lifting capability of the hydraulic elements, or the maximum permissible lifting capacity of the load hook.

LH 80 C EW – Equipment GA20

Industry – Kinematic 2A

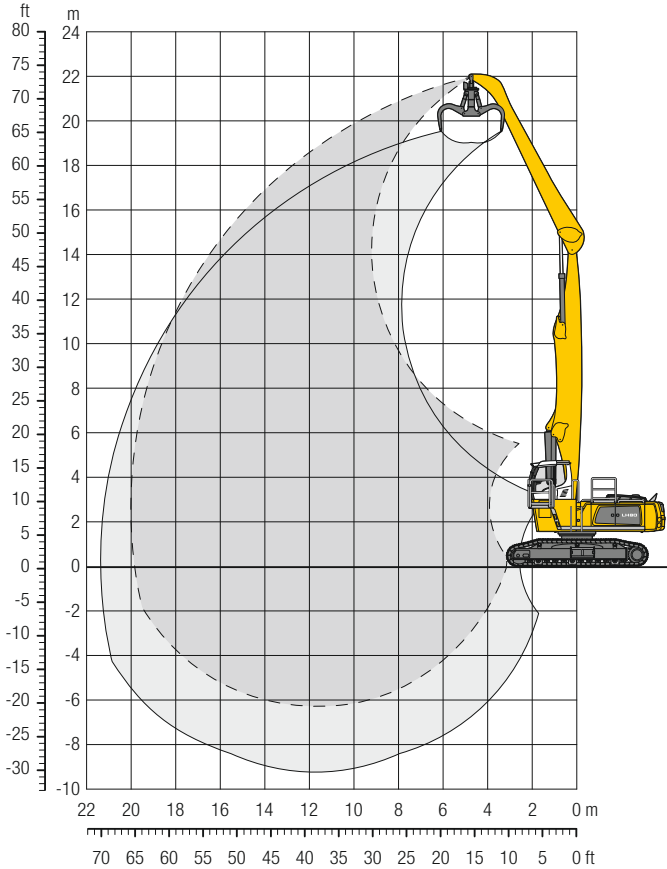

Dimensions

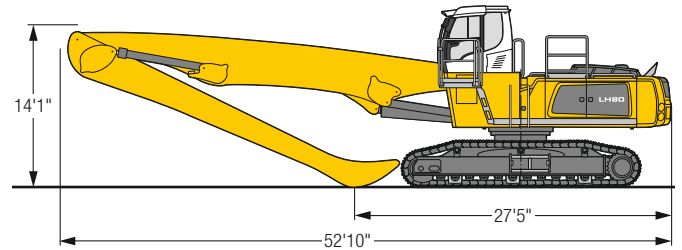

Operating weight and ground pressure

The operating weight includes the basic machine with rigid cab elevation, straight boom 37'9", angled stick 29'6" and multi-tine grab GMM 80-5 / 2.22 yd³ semi-closed tines.

Weight	152,100 lb
Pad width	24"
Ground pressure	on request

ft	Undercarriage	20 ft		25 ft		30 ft		35 ft		40 ft		45 ft		50 ft		55 ft		60 ft		65 ft		70 ft		ft in							
		EW	EW	EW	EW	EW	EW	EW	EW	EW	EW	EW	EW	EW	EW	EW	EW	EW	EW	EW	EW	EW	EW	EW	EW						
70	EW	29,3*	29,3*																					26,3*	26,3*	22' 8"					
65	EW			28,7*	28,7*	24,8*	24,8*																			20,9*	20,9*	33' 5"			
60	EW					27,9*	27,9*	24,7*	24,7*	19,6*	19,6*																	18,4*	18,4*	40'10"	
55	EW					28,7*	28,7*	24,9*	24,9*	22,6*	22,6*	19,2*	19,2*																16,9*	16,9*	46' 6"
50	EW							24,9*	24,9*	22,3*	22,3*	20,2*	20,2*	16,4	17,7*														15,6*	15,9*	51' 1"
45	EW							24,8*	24,8*	22,2*	22,2*	20,1*	20,1*	16,8	18,4*														13,4	15,2*	54'10"
40	EW							28,3*	28,3*	24,9*	24,9*	22,2*	22,2*	20,1*	20,1*	16,9	18,3*	13,6	16,9*										11,9	14,8*	57'10"
35	EW							28,7*	28,7*	25,1*	25,1*	22,4*	22,4*	20,2*	20,2*	16,7	18,4*	13,5	16,9*	10,9	14,4							10,7	14,3	60' 4"	
30	EW							29,3*	29,3*	25,5*	25,5*	22,6*	22,6*	20,1	20,3*	16,3	18,5*	13,3	16,9*	10,8	14,4							9,8	13,2	62' 2"	
25	EW							30,1*	30,1*	26,1*	26,1*	23,0*	23,0*	19,4	20,6*	15,8	18,6*	13,0	16,9*	10,7	14,2							9,2	12,5	63' 8"	
20	EW							30,1*	30,1*	26,7*	26,7*	22,8	23,4*	18,5	20,8*	15,2	18,8*	12,6	16,6	10,4	14,0							8,7	11,9	64'10"	
15	EW							31,0*	31,0*	26,9*	27,4*	21,5	23,9*	17,5	21,1*	14,5	18,9*	12,1	16,1	10,1	13,7							8,3	11,5	65' 6"	
10	EW							31,6*	33,0*	24,9	28,0*	20,1	24,2*	16,6	21,3*	13,8	18,3	11,6	15,6	9,8	13,3	8,5	11,7					8,1	11,2	65' 8"	
5	EW							21,5*	21,5*	37,6	41,1*	29,0	33,6*	23,1	28,4*	18,9	24,5*	15,6	20,9	13,1	17,7	11,1	15,1	9,5	13,0	8,1	11,3	8,0	11,1	65' 7"	
0	EW							15,6*	15,6*	34,6	39,2*	26,8	33,7*	21,6	28,4*	17,7	23,9	14,8	20,0	12,5	17,0	10,7	14,6	9,2	12,7	8,0	10,8*	8,0	10,8*	65' 1"	
-5	EW							15,2*	15,2*	30,3*	30,3*	25,2	32,9*	20,4	27,8*	16,8	23,0	14,2	19,4	12,1	16,5	10,4	14,3	9,0	12,5	8,1	9,6*	8,1	9,6*	64' 4"	
-10	EW							16,4*	16,4*	28,3*	28,3*	24,3	31,0*	19,6	26,4*	16,2	22,3	13,7	18,9	11,7	16,2	10,2	14,0*	8,9	10,9*	8,7	9,9*	8,7	9,9*	61' 2"	
-15	EW							28,7*	28,7*	23,8	27,6*	19,1	23,8*	15,8	20,5*	13,4	17,5*	11,5	14,7*	10,1	11,7*							9,9	11,1*	55'11"	
-20	EW									19,0	19,9*	15,7	17,2*															13,4	14,5*	44'10"	

Height Can be slewed through 360° In longitudinal position of undercarriage Max. reach * Limited by hydr. capacity

The lift capacities on the stick end without attachment are stated in lb x 1,000 and can be slewed through 360° on a firm, level supporting surface. Capacities are valid for 24" wide triple grouser pads (resp. flat pads). Indicated loads based on the ISO 10567 standard and do not exceed 75% of tipping or 87% of hydraulic capacity. The lift capacity values indicated are attained at the corresponding operating temperature. This operating temperature is ensured by continuous movement of the boom. Weights of fitted attachments (grabs, load hooks, etc.) and load accommodation attachment are to be deducted from the lift capacity values. The lift capacity of the unit is limited by its stability, the lifting capability of the hydraulic elements, or the maximum permissible lifting capacity of the load hook.

LH 80 C SW – Equipment AG20

Industry – Kinematic 2D

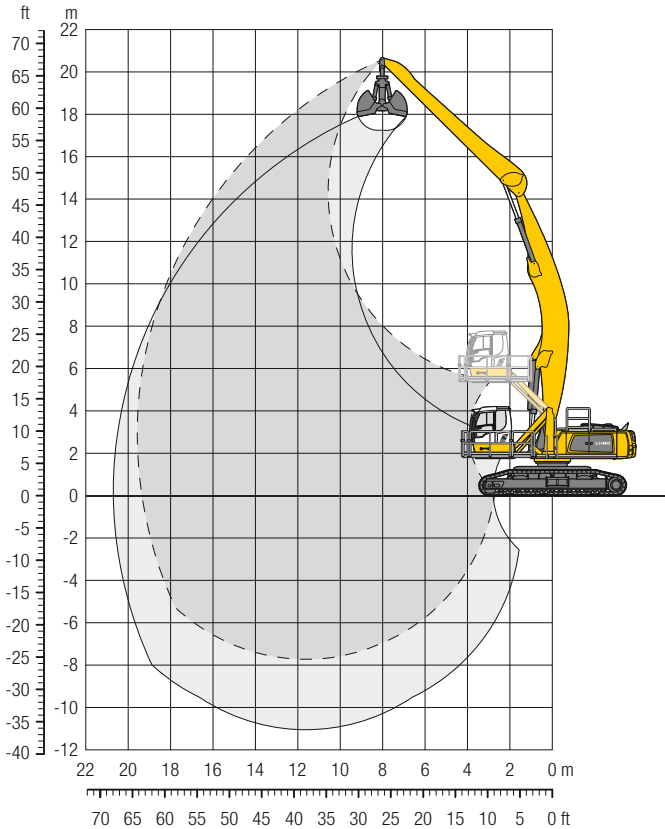

Dimensions

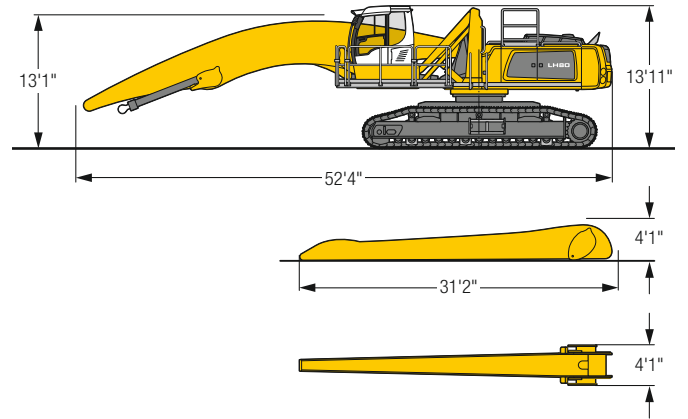

Operating weight and ground pressure

The operating weight includes the basic machine with hydr. cab elevation, angled boom 37°9', straight stick 29°6" and grab for loose material GMZ 80 / 3.92 yd³.

Weight	170,400 lb
Pad width	30"
Ground pressure	on request

ft	Undercarriage	20 ft		25 ft		30 ft		35 ft		40 ft		45 ft		50 ft		55 ft		60 ft		65 ft		70 ft		ft in					
		SW	SW	SW	SW	SW	SW	SW	SW	SW	SW	SW	SW	SW	SW	SW	SW	SW	SW	SW	SW	SW	SW	SW	SW				
70	SW																												
65	SW					22,3*	22,3*																	19,6*	19,6*	32' 6"			
60	SW							22,6*	22,6*																	17,5*	17,5*	40'	
55	SW									21,4*	21,4*	17,2*	17,2*														16,2*	16,2*	45' 8"
50	SW									23,1*	23,1*	21,1*	21,1*	19,6*	19,6*	15,8*	15,8*										15,4*	15,4*	50' 2"
45	SW									23,0*	23,0*	21,0*	21,0*	19,4*	19,4*	18,2*	18,2*										14,9*	14,9*	54'
40	SW									23,2*	23,2*	21,1*	21,1*	19,5*	19,5*	18,1*	18,1*	17,1*	17,1*								14,6*	14,6*	57'
35	SW									23,7*	23,7*	21,5*	21,5*	19,7*	19,7*	18,3*	18,3*	17,1*	17,1*								14,4*	14,4*	59' 5"
30	SW									24,4*	24,4*	21,9*	21,9*	20,0*	20,0*	18,5*	18,5*	17,2*	17,2*	16,0	16,2*						14,4*	14,4*	61' 5"
25	SW									28,7*	28,7*	25,2*	25,2*	22,6*	22,6*	20,5*	20,5*	18,8*	18,8*	17,5*	17,5*	15,8	16,3*				14,3	14,5*	62' 10"
20	SW	43,9*	43,9*	35,7*	35,7*	30,2*	30,2*	26,3*	26,3*	23,3*	23,3*	21,0*	21,0*	19,2*	19,2*	17,7*	17,7*	15,5	16,5*								13,6	14,7*	63' 11"
15	SW	48,1*	48,1*	38,2*	38,2*	31,9*	31,9*	27,4*	27,4*	24,2*	24,2*	21,6*	21,6*	19,6*	19,6*	17,8	18,0*	15,1	16,7*								13,1	15,0*	64' 6"
10	SW	52,2*	52,2*	40,8*	40,8*	33,6*	33,6*	28,6*	28,6*	25,0*	25,0*	22,3*	22,3*	20,1*	20,1*	17,2	18,3*	14,7	16,8*								12,7	15,4*	64' 10"
5	SW	24,3*	24,3*	43,0*	43,0*	35,1*	35,1*	29,7*	29,7*	25,8*	25,8*	22,8*	22,8*	19,5	20,5*	16,7	18,6*	14,4	16,9*								12,6	15,3*	64' 7"
0	SW	18,1*	18,1*	40,9*	40,9*	36,3*	36,3*	30,6*	30,6*	26,4	26,4*	22,1	23,3*	18,8	20,8*	16,2	18,7*	14,0	16,8*								12,6	15,1*	64' 1"
- 5	SW	17,3*	17,3*	32,1*	32,1*	36,9*	36,9*	30,6	31,1*	25,3	26,8*	21,3	23,5*	18,2	20,8*	15,8	18,6*	13,8	16,4*								12,7	14,9*	63' 1"
-10	SW	18,2*	18,2*	29,7*	29,7*	36,7*	36,7*	29,5	31,0*	24,5	26,7*	20,7	23,3*	17,8	20,6*	15,5	18,1*	13,6	15,6*								13,1	14,5*	61' 8"
-15	SW	19,8*	19,8*	29,7*	29,7*	35,6*	35,6*	28,9	30,2*	23,9	26,1*	20,3	22,7*	17,5	19,8*	15,3	17,0*										13,6	13,9*	59' 11"
-20	SW			31,0*	31,0*	33,2*	33,2*	28,5*	28,5*	23,7	24,6*	20,1	21,2*	17,4	18,2*	15,0*	15,0*										14,9*	14,9*	55' 1"
-25	SW							25,4*	25,4*	21,9*	21,9*																20,1*	20,1*	42' 8"
-30	SW																												

Height Can be slewed through 360° In longitudinal position of undercarriage Max. reach * Limited by hydr. capacity

The lift capacities on the stick end without attachment are stated in lb x 1,000 and can be slewed through 360° on a firm, level supporting surface. Capacities are valid for 30" wide triple grouser pads (resp. flat pads). Indicated loads based on the ISO 10567 standard and do not exceed 75% of tipping or 87% of hydraulic capacity. The lift capacity values indicated are attained at the corresponding operating temperature. This operating temperature is ensured by continuous movement of the boom. Weights of fitted attachments (grabs, load hooks, etc.) and load accommodation attachment are to be deducted from the lift capacity values. The lift capacity of the unit is limited by its stability, the lifting capability of the hydraulic elements, or the maximum permissible lifting capacity of the load hook.

LH 80 M HR – Equipment GA22

Industry – Kinematic 2A

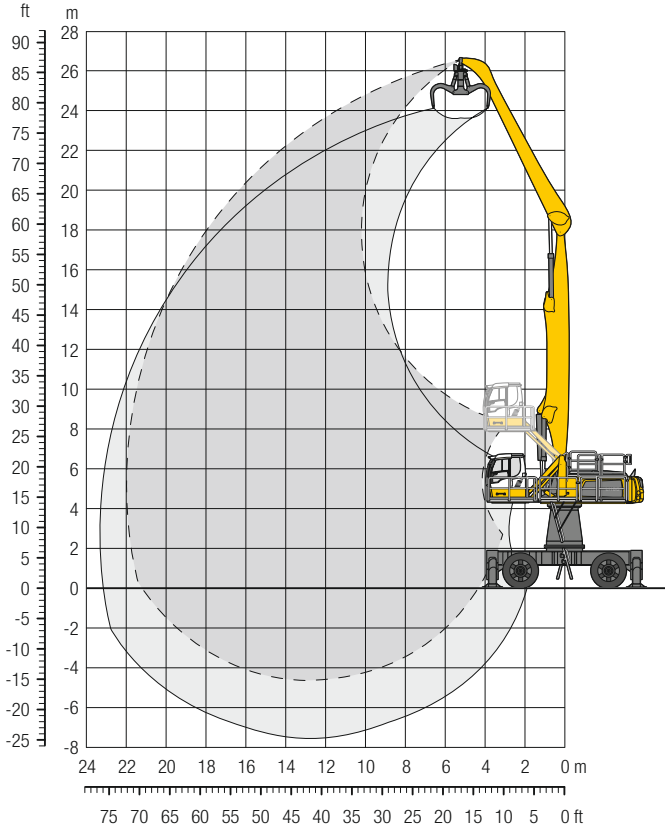

Dimensions

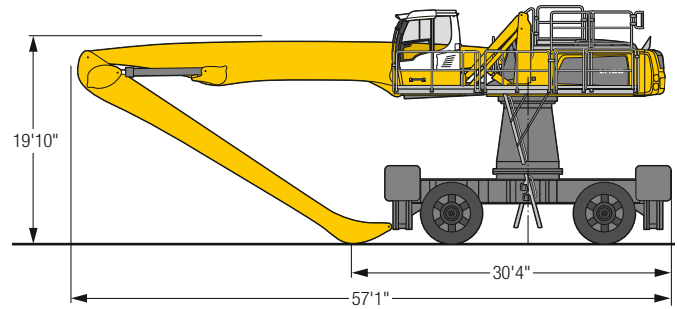

Operating weight

The operating weight includes the basic machine with 4 point outriggers, turret 6'7\", hydr. cab elevation, 4 solid tires, straight boom 41', angled stick 32'10\" and multi-tine grab GMM 80-5/2.22 yd³ semi-closed tines.

Weight 201,500 lb

ft	Undercarriage	20 ft		25 ft		30 ft		35 ft		40 ft		45 ft		50 ft		55 ft		60 ft		65 ft		70 ft		ft in		
		ft	in	ft	in	ft	in	ft	in	ft	in	ft	in	ft	in	ft	in	ft	in	ft	in	ft	in	ft	in	
85	4 pt. outriggers down	27,3*	27,3*																					24,1*	24,1*	23' 6"
80	4 pt. outriggers down					23,3*	23,3*																	19,0*	19,0*	34'11"
75	4 pt. outriggers down					25,5*	25,5*	23,0*	23,0*	19,5*	19,5*													16,6*	16,6*	42'10"
70	4 pt. outriggers down							24,8*	24,8*	22,5*	22,5*	19,3*	19,3*											15,1*	15,1*	48'11"
65	4 pt. outriggers down							25,8*	25,8*	23,6*	23,6*	21,2*	21,2*	18,6*	18,6*									14,2*	14,2*	53'11"
60	4 pt. outriggers down							26,4*	26,4*	23,4*	23,4*	21,1*	21,1*	19,1*	19,1*	17,3*	17,3*							13,5*	13,5*	58"
55	4 pt. outriggers down							26,4*	26,4*	23,4*	23,4*	21,0*	21,0*	19,1*	19,1*	17,4*	17,4*	15,1*	15,1*					13,0*	13,0*	61' 5"
50	4 pt. outriggers down							26,5*	26,5*	23,5*	23,5*	21,0*	21,0*	19,1*	19,1*	17,4*	17,4*	16,0*	16,0*					12,7*	12,7*	64' 2"
45	4 pt. outriggers down							26,7*	26,7*	23,6*	23,6*	21,1*	21,1*	19,1*	19,1*	17,4*	17,4*	15,9*	15,9*	14,6*	14,6*			12,5*	12,5*	66' 6"
40	4 pt. outriggers down					29,6*	29,6*	27,1*	27,1*	23,9*	23,9*	21,3*	21,3*	19,2*	19,2*	17,5*	17,5*	15,9*	15,9*	14,5*	14,5*			12,4*	12,4*	68' 5"
35	4 pt. outriggers down			29,5*	29,5*	32,0*	32,0*	27,6*	27,6*	24,2*	24,2*	21,5*	21,5*	19,3*	19,3*	17,5*	17,5*	16,0*	16,0*	14,5*	14,5*			12,4*	12,4*	69'11"
30	4 pt. outriggers down	30,0*	30,0*	35,9*	35,9*	32,9*	32,9*	28,1*	28,1*	24,6*	24,6*	21,8*	21,8*	19,5*	19,5*	17,6*	17,6*	16,0*	16,0*	14,4*	14,4*	12,8*	12,8*	12,4*	12,4*	71"
25	4 pt. outriggers down	51,6*	51,6*	40,8*	40,8*	33,7*	33,7*	28,7*	28,7*	24,9*	24,9*	22,0*	22,0*	19,6*	19,6*	17,6*	17,6*	15,9*	15,9*	14,3*	14,3*	12,6*	12,6*	11,9*	11,9*	71' 8"
20	4 pt. outriggers down	53,8*	53,8*	42,1*	42,1*	34,5*	34,5*	29,2*	29,2*	25,3*	25,3*	22,2*	22,2*	19,7*	19,7*	17,6*	17,6*	15,8*	15,8*	14,1*	14,1*	12,3*	12,3*	11,3*	11,3*	72' 1"
15	4 pt. outriggers down	18,2*	18,2*	43,0*	43,0*	35,1*	35,1*	29,6*	29,6*	25,5*	25,5*	22,3*	22,3*	19,7*	19,7*	17,5*	17,5*	15,6*	15,6*	13,8*	13,8*	11,8*	11,8*	10,6*	10,6*	72' 1"
10	4 pt. outriggers down	11,5*	11,5*	30,9*	30,9*	35,2*	35,2*	29,6*	29,6*	25,4*	25,4*	22,2*	22,2*	19,5*	19,5*	17,3*	17,3*	15,3*	15,3*	13,3*	13,3*	11,0*	11,0*	9,8*	9,8*	71' 8"
5	4 pt. outriggers down	10,7*	10,7*	22,6*	22,6*	34,5*	34,5*	29,1*	29,1*	25,0*	25,0*	21,8*	21,8*	19,1*	19,1*	16,8*	16,8*	14,6*	14,6*	12,5*	12,5*	9,7*	9,7*	8,9*	8,9*	71"
0	4 pt. outriggers down	11,6*	11,6*	20,6*	20,6*	33,0*	33,0*	28,0*	28,0*	24,1*	24,1*	21,0*	21,0*	18,3*	18,3*	15,9*	15,9*	13,6*	13,6*	11,2*	11,2*			8,0*	8,0*	69' 7"
-5	4 pt. outriggers down	13,2*	13,2*	20,8*	20,8*	30,2*	30,2*	26,1*	26,1*	22,5*	22,5*	19,6*	19,6*	16,9*	16,9*	14,5*	14,5*	12,1*	12,1*	9,2*	9,2*			8,7*	8,7*	65'10"
-10	4 pt. outriggers down			21,9*	21,9*	26,2*	26,2*	23,0*	23,0*	20,1*	20,1*	17,4*	17,4*	14,9*	14,9*	12,4*	12,4*							9,8*	9,8*	59'10"
-15	4 pt. outriggers down							16,5*	16,5*	14,3*	14,3*													13,3*	13,3*	47"

Height Can be slewed through 360° In longitudinal position of undercarriage Max. reach * Limited by hydr. capacity

The lift capacities on the stick end without attachment are stated in lb x 1,000 and are valid on a firm, level supporting surface with blocked oscillating axle. These capacities can be slewed through 360° with the undercarriage in the transverse position. Capacities in the longitudinal position of the undercarriage (±15°) are specified over the rigid axle with the stabilizers down. Indicated loads based on the ISO 10567 standard and do not exceed 75% of tipping or 87% of hydraulic capacity. The lift capacity values indicated are attained at the corresponding operating temperature. This operating temperature is ensured by continuous movement of the boom. Weights of fitted attachments (grabs, load hooks, etc.) and load accommodation attachment are to be deducted from the lift capacity values. The lift capacity of the unit is limited by its stability, the lifting capability of the hydraulic elements, or the maximum permissible lifting capacity of the load hook.

LH 80 M HR – Equipment AG22

Industry – Kinematic 2D

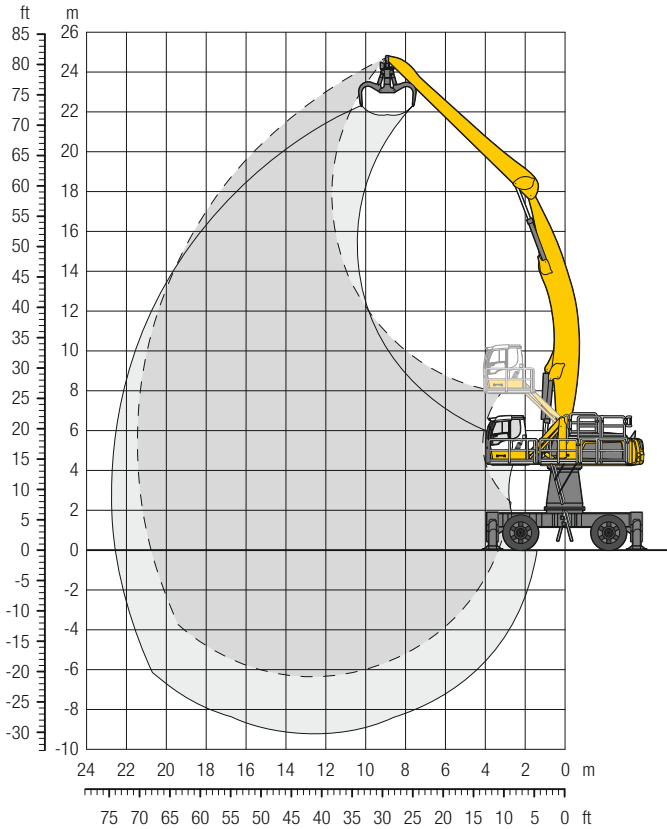

Dimensions

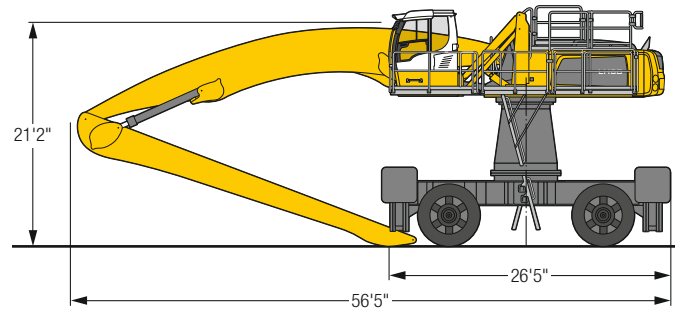

Operating weight

The operating weight includes the basic machine with 4 point outriggers, turret 6'7", hydr. cab elevation, 4 solid tires, angled boom 41', straight stick 32'10" and multi-tine grab GMM 80-5/1.83 yd³ semi-closed tines.

Weight 202,400 lb

ft	Undercarriage	Reach (ft)												ft in				
		20 ft	25 ft	30 ft	35 ft	40 ft	45 ft	50 ft	55 ft	60 ft	65 ft	70 ft	ft	in				
80	4 pt. outriggers down															18,0"	18,0"	31'
75	4 pt. outriggers down				19,4"	19,4"										15,7"	15,7"	39' 8"
70	4 pt. outriggers down					19,4"	19,4"	15,6"	15,6"							14,4"	14,4"	46' 2"
65	4 pt. outriggers down						19,7"	19,7"	17,9"	17,9"						13,6"	13,6"	51' 5"
60	4 pt. outriggers down							19,5"	19,5"	17,8"	17,8"	16,4"	16,4"	13,9"	13,9"	13,1"	13,1"	55' 8"
55	4 pt. outriggers down							19,5"	19,5"	17,7"	17,7"	16,3"	16,3"	15,1"	15,1"	12,7"	12,7"	59' 2"
50	4 pt. outriggers down							19,6"	19,6"	17,8"	17,8"	16,3"	16,3"	15,1"	15,1"	14,1"	14,1"	62' 2"
45	4 pt. outriggers down							19,9"	19,9"	18,0"	18,0"	16,4"	16,4"	15,2"	15,2"	14,1"	14,1"	64' 7"
40	4 pt. outriggers down							20,2"	20,2"	18,2"	18,2"	16,6"	16,6"	15,3"	15,3"	14,2"	14,2"	66' 6"
35	4 pt. outriggers down							20,7"	20,7"	18,6"	18,6"	16,9"	16,9"	15,5"	15,5"	14,3"	14,3"	68'
30	4 pt. outriggers down									26,9"	26,9"	23,4"	23,4"	20,7"	20,7"	18,6"	18,6"	70' 4"
25	4 pt. outriggers down											24,1"	24,1"	21,2"	21,2"	19,0"	19,0"	72' 11"
20	4 pt. outriggers down	44,2"	44,2"	35,1"	35,1"	29,2"	29,2"	25,0"	25,0"	21,8"	21,8"	19,4"	19,4"	17,5"	17,5"	15,9"	15,9"	74' 11"
15	4 pt. outriggers down	47,4"	47,4"	37,0"	37,0"	30,4"	30,4"	25,8"	25,8"	22,5"	22,5"	19,9"	19,9"	17,8"	17,8"	16,2"	16,2"	76' 11"
10	4 pt. outriggers down	26,3"	26,3"	38,8"	38,8"	31,6"	31,6"	26,7"	26,7"	23,1"	23,1"	20,4"	20,4"	18,2"	18,2"	16,4"	16,4"	78' 11"
5	4 pt. outriggers down	16,4"	16,4"	37,8"	37,8"	32,7"	32,7"	27,5"	27,5"	23,7"	23,7"	20,8"	20,8"	18,5"	18,5"	16,6"	16,6"	80' 11"
0	4 pt. outriggers down	14,4"	14,4"	27,0"	27,0"	33,3"	33,3"	28,0"	28,0"	24,1"	24,1"	21,0"	21,0"	18,7"	18,7"	16,7"	16,7"	82' 11"
-5	4 pt. outriggers down	14,5"	14,5"	23,8"	23,8"	33,5"	33,5"	28,2"	28,2"	24,2"	24,2"	21,1"	21,1"	18,7"	18,7"	16,6"	16,6"	84' 11"
-10	4 pt. outriggers down	15,4"	15,4"	23,1"	23,1"	33,0"	33,0"	27,9"	27,9"	24,0"	24,0"	20,9"	20,9"	18,4"	18,4"	16,3"	16,3"	86' 11"
-15	4 pt. outriggers down	16,7"	16,7"	23,5"	23,5"	31,6"	31,6"	27,0"	27,0"	23,3"	23,3"	20,3"	20,3"	17,8"	17,8"	15,5"	15,5"	88' 11"
-20	4 pt. outriggers down			24,5"	24,5"	29,2"	29,2"	25,2"	25,2"	21,9"	21,9"	19,0"	19,0"	16,5"	16,5"	14,2"	14,2"	90' 11"
	4 pt. outriggers down					22,5"	22,5"	19,6"	19,6"	16,9"	16,9"	14,5"	14,5"					92' 11"

Height **Can be slewed through 360°** **In longitudinal position of undercarriage** **Max. reach** * Limited by hydr. capacity

The lift capacities on the stick end without attachment are stated in lb x 1,000 and are valid on a firm, level supporting surface with blocked oscillating axle. These capacities can be slewed through 360° with the undercarriage in the transverse position. Capacities in the longitudinal position of the undercarriage (±15°) are specified over the rigid axle with the stabilizers down. Indicated loads based on the ISO 10567 standard and do not exceed 75% of tipping or 87% of hydraulic capacity. The lift capacity values indicated are attained at the corresponding operating temperature. This operating temperature is ensured by continuous movement of the boom. Weights of fitted attachments (grabs, load hooks, etc.) and load accommodation attachment are to be deducted from the lift capacity values. The lift capacity of the unit is limited by its stability, the lifting capability of the hydraulic elements, or the maximum permissible lifting capacity of the load hook.

LH 80 C HR – Equipment GA21

Industry – Kinematic 2A

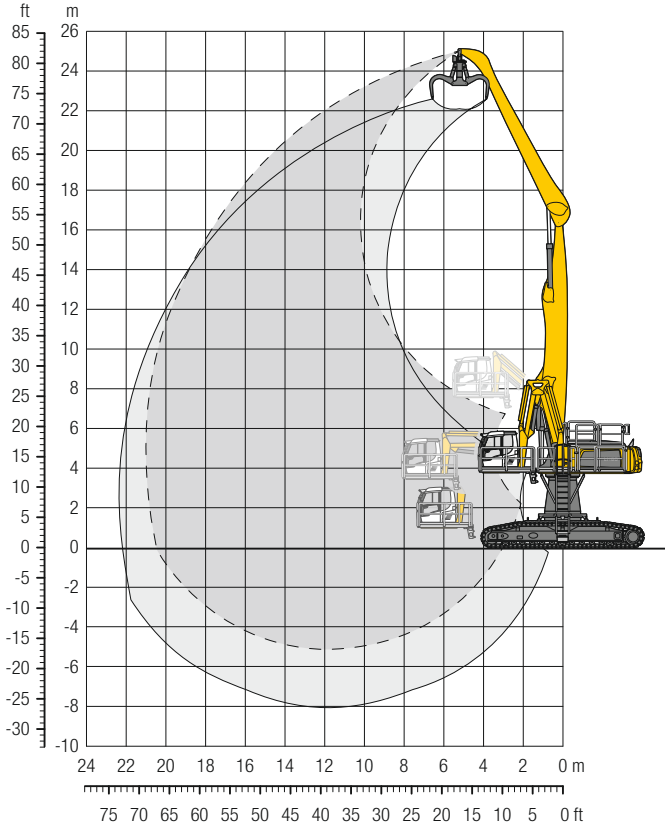

Dimensions

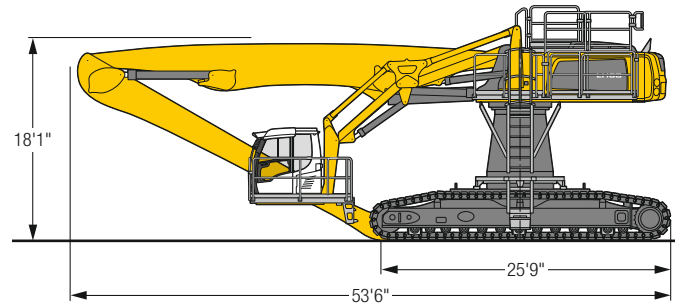

Operating weight and ground pressure

The operating weight includes the basic machine with turret 6'7", hydr. cab elevation, straight boom 37'9", angled stick 32'10" and multi-tine grab GMM 80-5/ 2.22 yd³ semi-closed tines.

Weight	208,100 lb
Pad width	30"
Ground pressure	on request

ft	Undercarriage	20 ft		25 ft		30 ft		35 ft		40 ft		45 ft		50 ft		55 ft		60 ft		65 ft		70 ft		ft in		
		SW	SW	SW	SW	SW	SW	SW	SW	SW	SW	SW	SW	SW	SW	SW	SW	SW	SW	SW	SW	SW	SW	SW	SW	
85	SW																							23,6"	23,6"	24'
80	SW					23,2"	23,2"																	18,7"	18,7"	34'10"
75	SW					25,5"	25,5"	22,9"	22,9"	19,0"	19,0"													16,4"	16,4"	42' 4"
70	SW							24,7"	24,7"	22,3"	22,3"	18,6"	18,6"											15,0"	15,0"	48' 1"
65	SW							25,8"	25,8"	24,1"	24,1"	21,6"	21,6"	17,6"	17,6"									14,0"	14,0"	52'10"
60	SW							26,5"	26,5"	23,9"	23,9"	21,7"	21,7"	20,0"	20"	15,8"	15,8"							13,4"	13,4"	56' 7"
55	SW							26,5"	26,5"	23,9"	23,9"	21,7"	21,7"	19,9"	19,9"	18,4"	18,4"							12,9"	12,9"	59'10"
50	SW							26,7"	26,7"	24,0"	24,0"	21,8"	21,8"	19,9"	19,9"	18,4"	18,4"	16,5"	16,5"					12,6"	12,6"	62' 5"
45	SW							27,1"	27,1"	24,2"	24,2"	21,9"	21,9"	20,0"	20,0"	18,4"	18,4"	17,0"	17,0"					12,5"	12,5"	64' 6"
40	SW							29,8"	29,8"	27,7"	27,7"	24,6"	24,6"	22,2"	22,2"	20,2"	20,2"	18,5"	18,5"	17,0"	17,0"	14,7"	14,7"	12,4"	12,4"	66' 2"
35	SW							32,6"	32,6"	28,4"	28,4"	25,1"	25,1"	22,5"	22,5"	20,4"	20,4"	18,6"	18,6"	17,0"	17,0"	15,5"	15,5"	12,4"	12,4"	67' 6"
30	SW			29,8"	29,8"	32,6"	32,6"	28,4"	28,4"	25,1"	25,1"	22,5"	22,5"	20,4"	20,4"	18,6"	18,6"	17,0"	17,0"	15,5"	15,5"			12,5"	12,5"	68' 4"
25	SW	31,0"	31,0"	37,2"	37,2"	33,9"	33,9"	29,2"	29,2"	25,7"	25,7"	22,9"	22,9"	20,6"	20,6"	18,7"	18,7"	17,0"	17,0"	15,4"	15,4"			12,7"	12,7"	68'10"
20	SW	53,2"	53,2"	42,3"	42,3"	35,1"	35,1"	30,1"	30,1"	26,2"	26,2"	23,3"	23,3"	20,9"	20,9"	18,8"	18,8"	17,0"	17,0"	15,2"	15,2"			12,7"	12,7"	68'10"
15	SW	56,3"	56,3"	44,2"	44,2"	36,3"	36,3"	30,8"	30,8"	26,7"	26,7"	23,6"	23,6"	21,0"	21,0"	18,8"	18,8"	16,8"	16,8"	14,8"	14,8"			12,7"	12,7"	68'11"
10	SW	27,2"	27,2"	45,4"	45,4"	37,1"	37,1"	31,3"	31,3"	27,0"	27,0"	23,7"	23,7"	21,0"	21,0"	18,7"	18,7"	16,5"	16,5"	14,2"	14,2"			12,0"	12,0"	68' 8"
5	SW	18,0"	18,0"	45,3"	45,3"	37,3"	37,3"	31,4"	31,4"	27,0"	27,0"	23,6"	23,6"	20,7"	20,7"	18,2"	18,2"	15,9"	15,9"	13,3"	13,3"			11,0"	11,0"	68'
0	SW	16,5"	16,5"	32,7"	32,7"	36,7"	36,7"	30,9"	30,9"	26,5"	26,5"	23,0"	23,0"	20,1"	20,1"	17,5"	17,5"	14,9"	14,9"	11,7"	11,7"			9,9"	9,9"	67'
- 5	SW	17,1"	17,1"	29,4"	29,4"	34,8"	34,8"	29,5"	29,5"	25,3"	25,3"	21,9"	21,9"	18,9"	18,9"	16,1"	16,1"	13,1"	13,1"					10,3"	10,3"	63'10"
- 10	SW	18,6"	18,6"	29,0"	29,0"	31,5"	31,5"	27,0"	27,0"	23,2"	23,2"	19,9"	19,9"	16,9"	16,9"	13,9"	13,9"							11,5"	11,5"	58' 7"
- 15	SW					26,5"	26,5"	23,1"	23,1"	19,9"	19,9"	16,8"	16,8"											14,2"	14,2"	49' 5"
- 20	SW																									

Height Can be slewed through 360° In longitudinal position of undercarriage Max. reach * Limited by hydr. capacity

The lift capacities on the stick end without attachment are stated in lb x 1,000 and can be slewed through 360° on a firm, level supporting surface. Capacities are valid for 30" wide flat pads. Indicated loads based on the ISO 10567 standard and do not exceed 75% of tipping or 87% of hydraulic capacity. The lift capacity values indicated are attained at the corresponding operating temperature. This operating temperature is ensured by continuous movement of the boom. Weights of fitted attachments (grabs, load hooks, etc.) and load accommodation attachment are to be deducted from the lift capacity values. The lift capacity of the unit is limited by its stability, the lifting capability of the hydraulic elements, or the maximum permissible lifting capacity of the load hook.

LH 80 C Gantry – Equipment AG22

Industry – Kinematic 2C

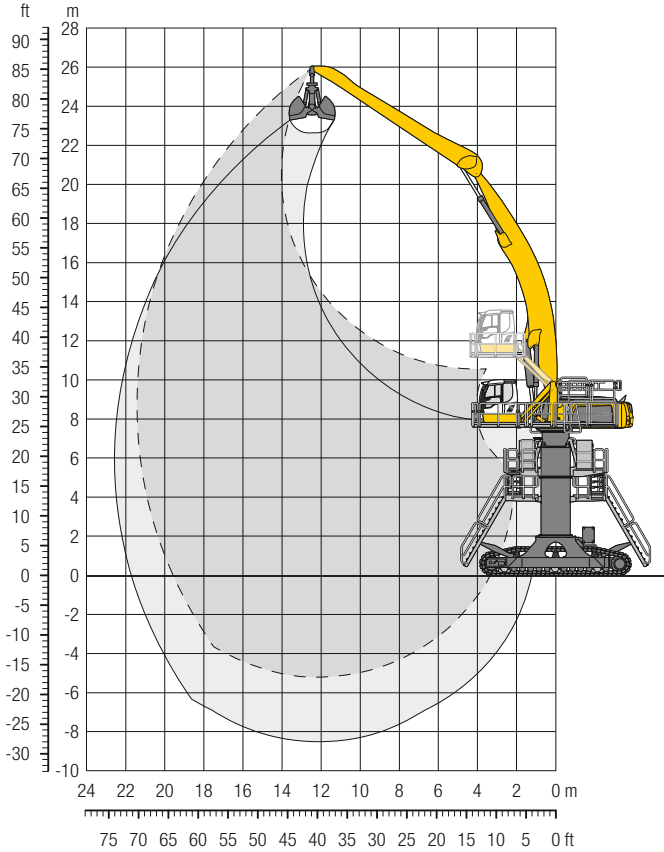

Dimensions

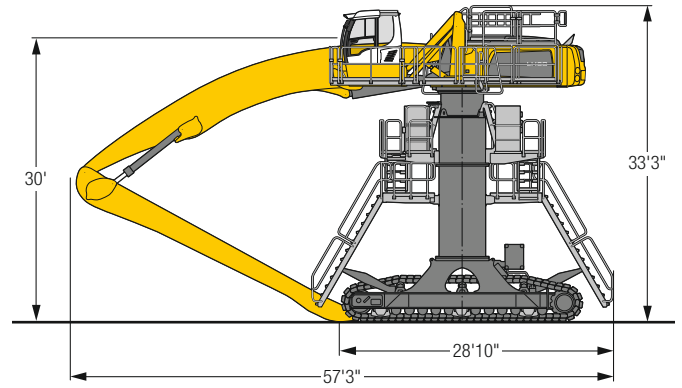

Operating weight and ground pressure

The operating weight includes the basic machine with hydr. cab elevation, angled boom 41', straight stick 32'10" and grab for loose material GMZ 80 / 3.92 yd³.

Weight	248,000 lb
Pad width	30"
Ground pressure	on request

ft	Undercarriage	20 ft		25 ft		30 ft		35 ft		40 ft		45 ft		50 ft		55 ft		60 ft		65 ft		70 ft		ft in				
		☞	☞	☞	☞	☞	☞	☞	☞	☞	☞	☞	☞	☞	☞	☞	☞	☞	☞	☞	☞	☞	☞	☞	☞			
85	Gantry																							15,4"	15,4"	41' 1"		
80	Gantry											16,3"	16,3"												14,2"	14,2"	47' 5"	
75	Gantry													14,9"	14,9"										13,5"	13,5"	52' 5"	
70	Gantry													14,7"	14,7"	13,8"	13,8"								13,0"	13,0"	56' 6"	
65	Gantry													14,6"	14,6"	13,7"	13,7"								12,7"	12,7"	59' 11"	
60	Gantry													14,7"	14,7"	13,7"	13,7"	12,9"	12,9"							12,5"	12,5"	62' 8"
55	Gantry											16,1"	16,1"	14,8"	14,8"	13,8"	13,8"	13,0"	13,0"	12,3"	12,3"					12,3"	12,3"	65"
50	Gantry											16,4"	16,4"	15,1"	15,1"	14,0"	14,0"	13,1"	13,1"	12,4"	12,4"					12,1"	12,1"	66' 11"
45	Gantry									18,7"	18,7"	16,8"	16,8"	15,4"	15,4"	14,2"	14,2"	13,2"	13,2"	12,5"	12,5"					12,0"	12,0"	68' 4"
40	Gantry							21,9"	21,9"	19,3"	19,3"	17,3"	17,3"	15,7"	15,7"	14,5"	14,5"	13,4"	13,4"	12,6"	12,6"					12,0"	12,0"	69' 4"
35	Gantry	40,5"	40,5"	32,1"	32,1"	26,7"	26,7"	22,8"	22,8"	20,0"	20,0"	17,9"	17,9"	16,2"	16,2"	14,8"	14,8"	13,7"	13,7"	12,8"	12,8"					12,0"	12,0"	70"
30	Gantry	44,1"	44,1"	34,3"	34,3"	28,1"	28,1"	23,9"	23,9"	20,8"	20,8"	18,5"	18,5"	16,6"	16,6"	15,1"	15,1"	13,9"	13,9"	12,9"	12,9"	12,0"	12,0"			12,0"	12,0"	70' 4"
25	Gantry	22,8"	22,8"	36,4"	36,4"	29,6"	29,6"	24,9"	24,9"	21,6"	21,6"	19,0"	19,0"	17,1"	17,1"	15,5"	15,5"	14,2"	14,2"	13,1"	13,1"	12,0"	12,0"			12,0"	12,0"	70' 2"
20	Gantry	15,7"	15,7"	34,4"	34,4"	30,9"	30,9"	25,9"	25,9"	22,3"	22,3"	19,6"	19,6"	17,5"	17,5"	15,8"	15,8"	14,4"	14,4"	13,2"	13,2"					12,0"	12,0"	69' 10"
15	Gantry	14,3"	14,3"	26,1"	26,1"	31,9"	31,9"	26,7"	26,7"	22,9"	22,9"	20,1"	20,1"	17,8"	17,8"	16,0"	16,0"	14,5"	14,5"	13,1"	13,1"					11,5"	11,5"	64' 2"
10	Gantry	14,6"	14,6"	23,5"	23,5"	32,4"	32,4"	27,2"	27,2"	23,3"	23,3"	20,4"	20,4"	18,0"	18,0"	16,1"	16,1"	14,5"	14,5"	12,9"	12,9"					12,0"	12,0"	67' 10"
5	Gantry	15,7"	15,7"	23,1"	23,1"	32,3"	32,3"	27,2"	27,2"	23,4"	23,4"	20,4"	20,4"	18,0"	18,0"	16,0"	16,0"	14,2"	14,2"	12,3"	12,3"					11,8"	11,8"	66' 4"
0	Gantry	17,0"	17,0"	23,7"	23,7"	31,4"	31,4"	26,6"	26,6"	23,0"	23,0"	20,0"	20,0"	17,6"	17,6"	15,5"	15,5"	13,4"	13,4"							11,5"	11,5"	64' 2"
-5	Gantry	18,5"	18,5"	24,8"	24,8"	29,5"	29,5"	25,3"	25,3"	21,9"	21,9"	19,1"	19,1"	16,6"	16,6"	14,4"	14,4"	12,0"	12,0"							11,0"	11,0"	61' 10"
-10	Gantry	20,1"	20,1"	26,4"	26,4"	26,5"	26,5"	23,0"	23,0"	20,0"	20,0"	17,3"	17,3"	14,9"	14,9"	12,4"	12,4"									10,2"	10,2"	58' 8"
-15	Gantry			22,1"	22,1"	19,5"	19,5"	17,0"	17,0"					14,5"	14,5"	11,9"	11,9"									11,2"	11,2"	51' 4"

☞ Height ☞ Can be slewed through 360° ☞ In longitudinal position of undercarriage ☞ Max. reach * Limited by hydr. capacity

The lift capacities on the stick end without attachment are stated in lb x 1,000 and can be slewed through 360° on a firm, level supporting surface. Capacities are valid for 30" wide flat pads. Indicated loads based on the ISO 10567 standard and do not exceed 75% of tipping or 87% of hydraulic capacity. The lift capacity values indicated are attained at the corresponding operating temperature. This operating temperature is ensured by continuous movement of the boom. Weights of fitted attachments (grabs, load hooks, etc.) and load accommodation attachment are to be deducted from the lift capacity values. The lift capacity of the unit is limited by its stability, the lifting capability of the hydraulic elements, or the maximum permissible lifting capacity of the load hook.

Liebherr ERC-System

More performance, less consumption

Lowering the equipment stores energy in the ERC-System. This stored energy is then made available to the machine to provide additional engine power. When the equipment is raised the stored energy is released and is reflected in powerful, homogeneous operating cycles. The result is a clear energy saving – and, at the same time, even greater performance.

System performance

The energy recovery cylinder is a storage system which is independent of the electric motor or diesel engine. The system performance of material handling machines fitted with the ERC-System is composed of the installed engine power and the energy recovery cylinder. When the equipment is raised, energy from the ERC-System is supplied in addition to the power from the engine.

ERC-System

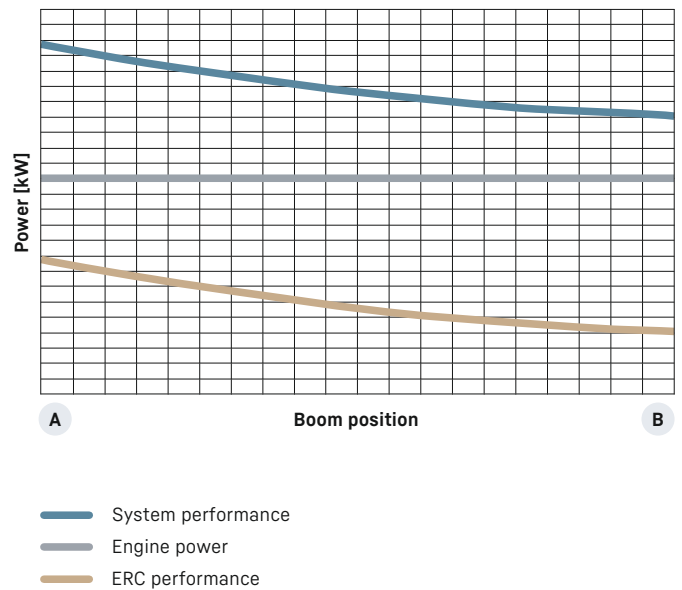

B 1. Equipment fitting raised / energy released

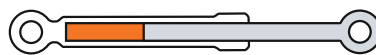

2. Lower equipment fitting / store energy
4. Raise equipment fitting / release energy



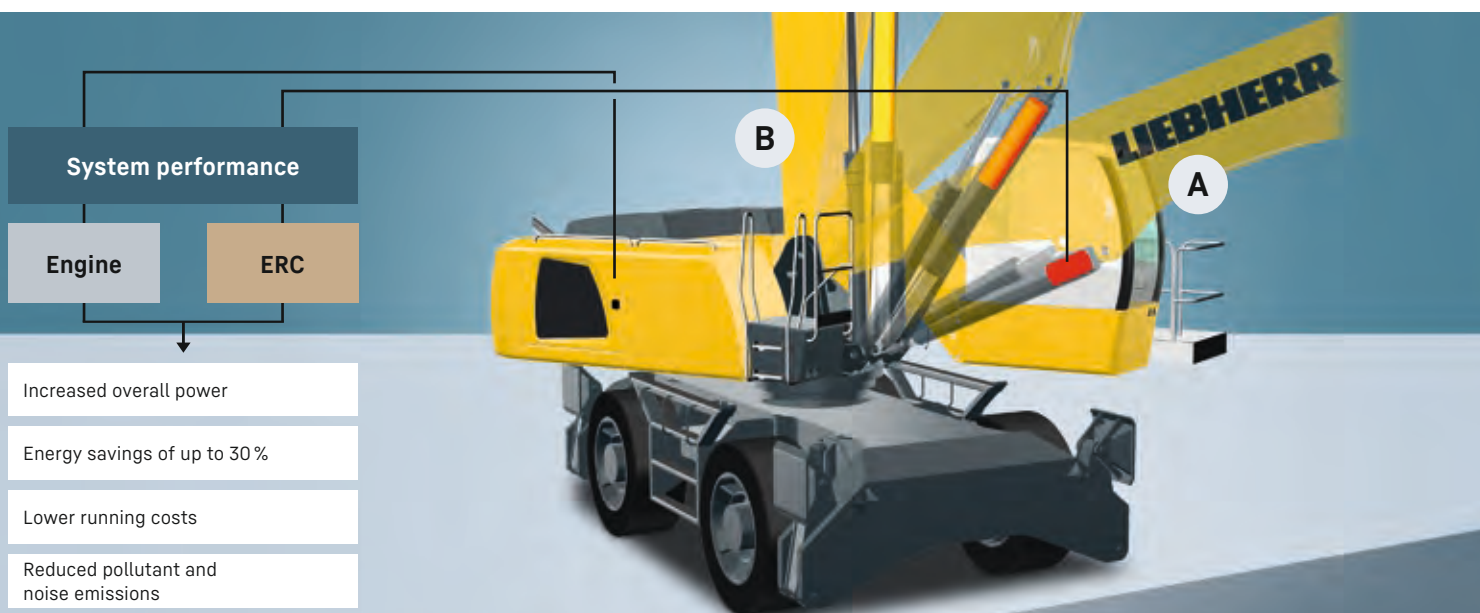

A 3. Equipment fitting lowered / energy stored



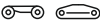

Equipment

	80 M	80 C	80 M HR	80 C HR	80 C Gantry
 Undercarriage					
Track pads, variants		+		+	+
Individual control outriggers	+		•		
Three-piece chain guide		•		•	•
Shuttle axle lock, automatic	•		•		
Outrigger monitoring system	+		+		
Tires, variants	+		+		
Trailing cable ²⁾	•	•	•	•	•
Protection for piston rods, outriggers	+		+		
Two storage compartments ¹⁾	•				
One storage compartment ²⁾	•				
Undercarriage, variants		+			
Cable reel system ²⁾	+	+ ³⁾	+	+	+

	80 M	80 C	80 M HR	80 C HR	80 C Gantry
 Uppercarriage					
Uppercarriage right side light, 1 piece, LED	•	•	•	•	•
Uppercarriage rear light, 2 pieces, LED	+	+			
Uppercarriage underneath rear light, 1 piece, LED			+	+	+
Refuelling system with filling pump ¹⁾	+	+	+	+	+
Railing on uppercarriage	+	+	•	•	•
Generator	+	+	+	+	+
Main battery switch for electrical system	•	•	•	•	•
Amber beacon, at uppercarriage, LED double flash	+	+	+	+	+
Protection for headlights	+				
Protection for rear lights	+	+			
Tool equipment, extended	•	•	•	•	•

	80 M	80 C	80 M HR	80 C HR	80 C Gantry
 Hydraulic system					
Electronic pump regulation	•	•	•	•	•
Liebherr hydraulic oil from -4°F to +104°F	•	•	•	•	•
Liebherr hydraulic oil, biologically degradable	+	+	+	+	+
Liebherr hydraulic oil, specially for warm or cold regions	+	+	+	+	+
Magnetic rod in hydraulic tank	•	•	•	•	•
Bypass filter	+	+	+	+	+
Preheating hydraulic oil	+	+	+	+	+

	80 M	80 C	80 M HR	80 C HR	80 C Gantry
 Engine					
Fuel anti-theft device ¹⁾	+	+	+	+	+
Air pre-filter with dust discharge ¹⁾	+	+	+	+	+
Automatic engine shut-down (time adjustable)	+	+	+	+	+
Preheating fuel ¹⁾	+	+	+	+	+
Preheating coolant ¹⁾	+	+	+	+	+
Preheating engine oil ^{*1)}	+	+	+	+	+

	80 M	80 C	80 M HR	80 C HR	80 C Gantry
 Cooling system					
Reversible fan drive	+	+	+	+	+
Protective grid in front of cooler intake	•	•	•	•	•



Cab

	80 M	80 C	80 M HR	80 C HR	80 C Gantry
Support assistant	+		+		
Stabilizer, control lever, left console	+		+		
Stabilizer, proportional control on left joystick	●		●		
Cab lights rear, halogen	+	+	+	+	+
Cab lights rear, LED	+	+	+	+	+
Cab lights front, halogen	+	+	+	+	
Cab lights front, halogen (under rain cover)	●	●	●	●	●
Cab lights front, LED	+	+	+	+	+
Cab lights front, LED (under rain cover)	+	+	+	+	+
Armrest adjustable	●	●	●	●	●
Circular bubble level	+	+	●	●	●
Slewing gear brake Comfort, button on the left or right joystick	+	+	+	+	+
Driver profile, personalized (max. 5 drivers)	+	+	+	+	+
Operator's seat Comfort	●	●	●	●	●
Operator's seat Premium	+	+	+	+	+
Driving alarm (acoustic signal is emitted during travel, can be switched ON / OFF)	+	+	+	+	+
Fire extinguisher	+	+	+	+	+
Footrest	+	+	+	+	+
Horn, button on left joystick	●	●	●	●	●
Joystick steering	●	●	●	●	●
Joystick and wheel steering (slim version)	+	+			
Cab elevation, hydraulic (LHC)	●	●	●	●	●
Cab elevation, hydraulic with double parallelogram (LHC-D)			+	+	+
Cab elevation, rigid (LFC)	+	+			
Automatic air conditioning	●	●	●	●	●
Wheel steering (slim version)	+		+		
LiDAT, vehicle fleet management	●	●	●	●	●
Engine shut-down (emergency stop) cab ²⁾	●	●	●	●	●
Proportional control	●	●	●	●	●
Radio Comfort, control via display with handsfree set	+	+	+	+	+
Preparation for radio installation	●	●	●	●	●
Back-up alarm (acoustic signal is emitted traveling backward, can not be switched off)	+		+		
Amber beacon, on cab, LED double flash	+	+	+	+	+
Windows made from impact-resistant laminated safety glass	+	+	●	●	●
Windscreen wiper, roof	+	+	+	+	+
Windshield wiper, entire windshield	●	●	●	●	●
FOPS top guard	+	+	+	+	+
FGPS front guard, tiltable	+	+	+	+	+
Sun visor	+	+	+	+	+
Stationary air-conditioning ²⁾	●	●	●	●	●
Left control console, folding	●	●	●	●	●



Equipment

	80 M	80 C	80 M HR	80 C HR	80 C Gantry
Boom lights, 2 pieces, halogen	●	●	●	●	●
Boom lights, 2 pieces, LED	+	+	+	+	+
Stick lights, 2 pieces, halogen	●	●	●	●	●
Stick lights, 2 pieces, LED	+	+	+	+	+
Boom shutoff (retract / extend), electronically	+	+	●	●	●
Equipment with electro-hydraulic end position control	●	●	●	●	●
AutoLift	+	+	+	+	+
Pressure warning mechanism hoist cylinder	●	●	●	●	●
ERC system	●	●	●	●	●
Filter system for attachment	+	+	+	+	+
Electronic lift limitation	+	+	+	+	+
Boom cylinder cushioning	●	●	●	●	●
Stick camera (with separate monitor), bottom side, with protection	+	+	+	+	+
Load torque limitation	+	+	+	+	+
Liebherr multi coupling system	+	+	+	+	+
Pipe fracture safety valves hoist cylinders	●	●	●	●	●
Pipe fracture safety valves stick cylinders	●	●	●	●	●
Quick coupling system MH 110B	+	+	+	+	+
Protection for piston rod, energy recovering cylinder	+	+	+	+	+
Protection for piston rods, hoist cylinder	+	+	+	+	+
Stick shutoff (retract), electronically	●	●	●	●	●
Stick shutoff (retract / extend), electronically	+	+	+	+	+
Retract stick without pressure	●	●	●	●	●
Sticks with quick coupling	+	+	+	+	+
Overload warning device	+	+	+	+	+



Complete machine

	80 M	80 C	80 M HR	80 C HR	80 C Gantry
Lubrication					
Lubrication undercarriage, manually - decentralized (grease points)	●				
Lubrication undercarriage, manually - centralized (one grease point)	+		●		
Central lubrication system for uppercarriage and equipment, automatically	●	●	●	●	●
Central lubrication system for undercarriage, automatically	+		+		
Centralized lubrication extended for attachment	+	+	+	+	+
Special coating					
Special coating, variants	+	+	+	+	+
Monitoring					
Rear view monitoring with camera	●	●	●	●	●
Side view monitoring with camera	●	●	●	●	●

● = Standard, + = Option, +³⁾ = on request

* = country-dependent, ¹⁾ not with electric drive, ²⁾ only with electric drive

Options and / or special equipment, supplied by vendors other than Liebherr, are only to be installed with the knowledge and approval of Liebherr in order to retain warranty.

Attachments

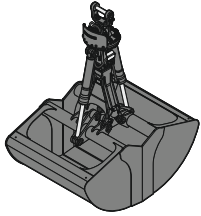

Grab for loose material

Shells for loose material with cutting edge (without teeth)

Grab model GMZ 50							
Width of shells	ft in	4'7"	5'3"	5'11"			
Capacity	yd ³	4.58	5.23	5.88			
Weight	lb	5,765	6,065	6,230			
Grab model GMZ 80							
Width of shells	ft in	4'3"	4'11"	5'9"	6'7"	7'3"	8'6"
Capacity	yd ³	3.92	4.58	5.23	5.88	6.54	7.85
Weight	lb	5,535	5,785	6,120	6,435	7,175	7,695
Grab model GMZ 120							
Width of shells	ft in	5'3"	5'11"	6'7"	7'3"		
Capacity	yd ³	5.23	5.88	6.54	7.19		
Weight	lb	6,625	6,925	7,230	8,005		



Multi-tine grab

open

semi-closed

closed, heart-shaped

Grab model GMM 80-4 (4 tines)		open			semi-closed			closed, heart-shaped					
Capacity	yd ³	1.44	1.83	2.22	1.44	1.83	2.22	1.83	2.22				
Weight	lb	4,190	4,275	4,410	4,620	4,740	4,870	5,300	5,645				
Grab model GMM 120-4 (4 tines)		open			semi-closed			closed, heart-shaped					
Capacity	yd ³	2.22	2.62	3.27	3.92	2.22	2.62	3.27	3.92				
Weight	lb	4,750	4,850	4,970	5,080	5,270	5,390	5,590	5,785				
Grab model GMM 80-5 (5 tines)		open			semi-closed			closed, heart-shaped					
Capacity	yd ³	1.44	1.83	2.22	1.18	1.44	1.83	2.22	1.18	1.44	1.83	2.22	
Weight	lb	4,785	4,895	5,050	4,995	5,270	5,435	5,590	5,235	5,380	5,690	6,020	
Grab model GMM 120-5 (5 tines)		open			semi-closed			closed, heart-shaped					
Capacity	yd ³	2.22	2.62	3.27	3.92	2.22	2.62	3.27	3.92	2.22	2.62	3.27	3.92
Weight	lb	5,480	5,600	5,755	5,885	6,085	6,240	6,470	6,725	6,550	6,855	7,200	8,090



Wood grab

Grab model GMH 80 – round overlapping (vertical cylinders)							
Size	yd ²	1.55	1.91	2.27	2.63	2.99	
Cutting width	ft in	2'10"	2'10"	2'10"	2'10"	2'10"	2'10"
Height of grab, closed	ft in	9'2"	9'6"	9'9"	10'1"	10'4"	
Weight	lb	4,750	4,885	4,980	5,060	5,150	
Grab model GMH 120 – round overlapping (vertical cylinders)							
Size	yd ²	3.35	3.83	3.35			
Cutting width	ft in	2'10"	2'10"	2'10"			
Height of grab, closed	ft in	11'9"	12'1"	12'4"			
Weight	lb	6,010	6,065	6,150			

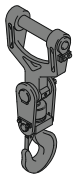

Load hook

Max. load	lb	55,115
Height with suspension	ft	4'
Weight	lb	562

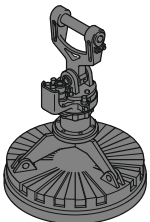

Magnet devices / lifting magnets

Generator	kW	20	30
Electromagnet with suspension			
Power	kW	11.7	17.8
Diameter of magnet	ft in	4'11"	5'7"
Weight	lb	5,290*	7,275*

* only magnet plate

Liebherr USA, Co.

Construction Equipment Division • 4800 Chestnut Avenue • Newport News, VA 23607, USA • Phone +1 (757) 240 4250
 construction.usa@liebherr.com • www.liebherr.us • www.facebook.com/LiebherrConstruction