

Technical Description Rubber Tyre Gantry Crane

RTG



LIEBHERR

Technical Data

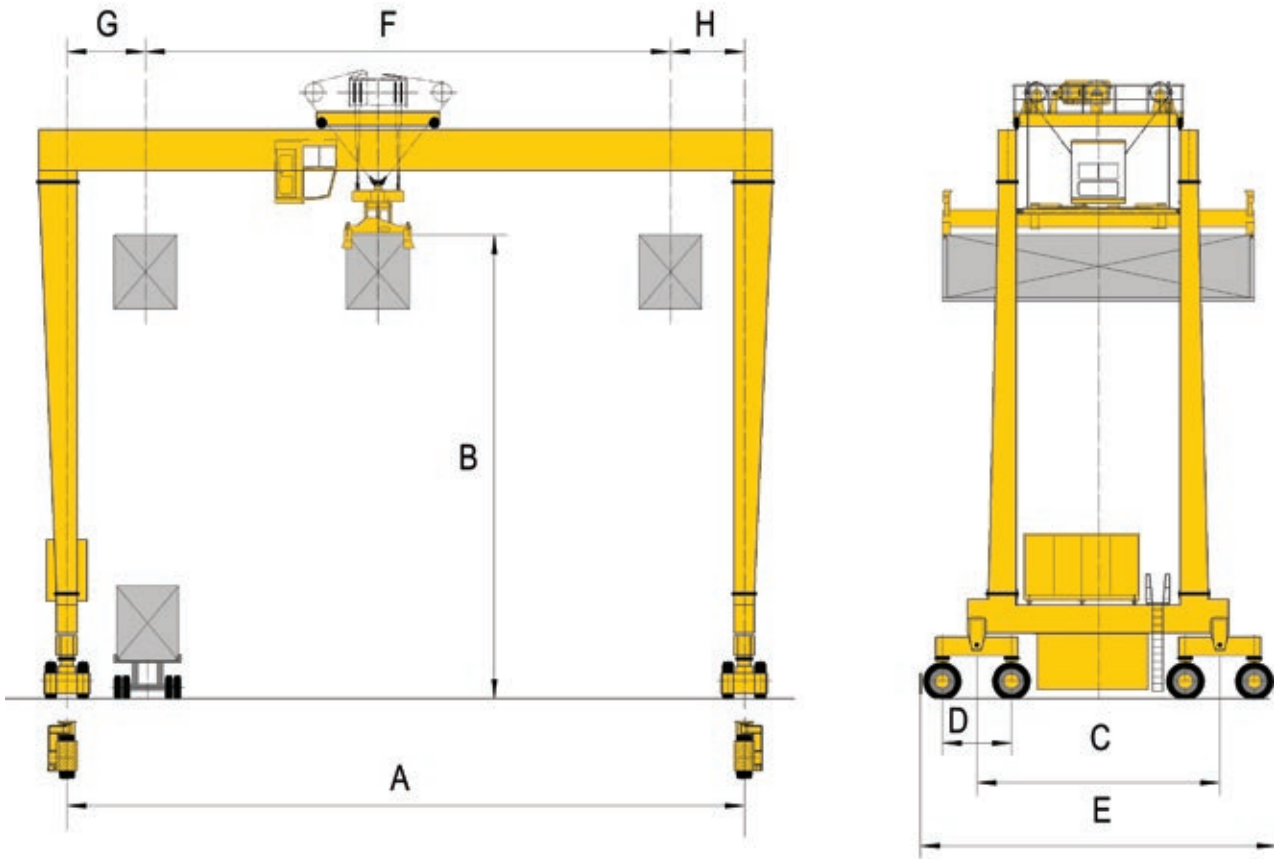

RTG Model Designation

7/5/4 WS

7	AC drive
5	4 wheels per corner
4	1 over 5 high stacking
WS	7 containers wide + truck lane

RTG Model Range*

A Typical gantry span	20.8 m for 5 wide + truck lane 23.6 m for 6 wide + truck lane 26.5 m for 7 wide + truck lane 29.4 m for 8 wide + truck lane 32.3 m for 9 wide + truck lane 37.7 m for 10 wide + truck lane
B Lifting Heights	12.3 m for 1 over 3 15.2 m for 1 over 4 18.2 m for 1 over 5 21 m for 1 over 6
SWL	40.6 - 50 t single 50 - 60 t twin
C Travel wheel gauge	9.2 m
D Rocker length	2.5 m
E Length over travel guards	13.3 m for 4 wheels per corner 13.7 m for 2 wheels per corner
F Trolley travel	Gantry span minus end approach
G Trolley end approach	2.4 m
H Trolley end approach	2.25 m

Typical Design Parameters

Classification according to F.E.M.	U7-Q2-A7 (Single lift)
In service wind speed	72 km/h (20 m/s)
Out of service wind speed	151.2 km/h (42 m/s)
Maximum yard slope	1:100 in either direction
Self weight (model dependant)	116 t to 138 t

Working Speeds**

Hoisting with no load	56 m/min
Hoisting with rated load	28 m/min
Trolley travel (with and without load)	70 m/min
Gantry travel without load	130 m/min
Gantry travel with rated load	70 m/min
Stack transfer without load	70 m/min

**Alternative speeds also available

Wheel Dimensions and Loading

Tyre size (8 wheel)	18.00 - 25/21.00 - 25
Tyre size (16 wheel)	14.00 - 24/16.00 - 25
Avg./Max. wheel load (model 7/5/2)	24.5 t/34.8 t
Avg./Max. wheel load (model 7/5/4)	12.2 t/17.2 t

Generator Set

Engine type	Volvo/Cummins
Alternator type	Marelli/Stamford
Diesel fuel tank capacity	1000 l/1500 l
Operating voltage/frequency	480 V/60 Hz
Generator set rating, continuous	400 kVA

Drive Power

Hoist unit (40.6 t)	1 X 190 kW AC
Trolley unit	2 X 18 kW AC
Gantry travel unit (8 wheels)	4 X 35 kW AC
Gantry travel unit (16 wheels)	4 X 35 kW AC

Drive Power

Switchgear/control system designed and built by Liebherr using well proven robust components and CMS system in accordance with IEC 61131

*Other features and dimensions also available

Liebherr Anti-Sway System (Eight Rope Reeving)

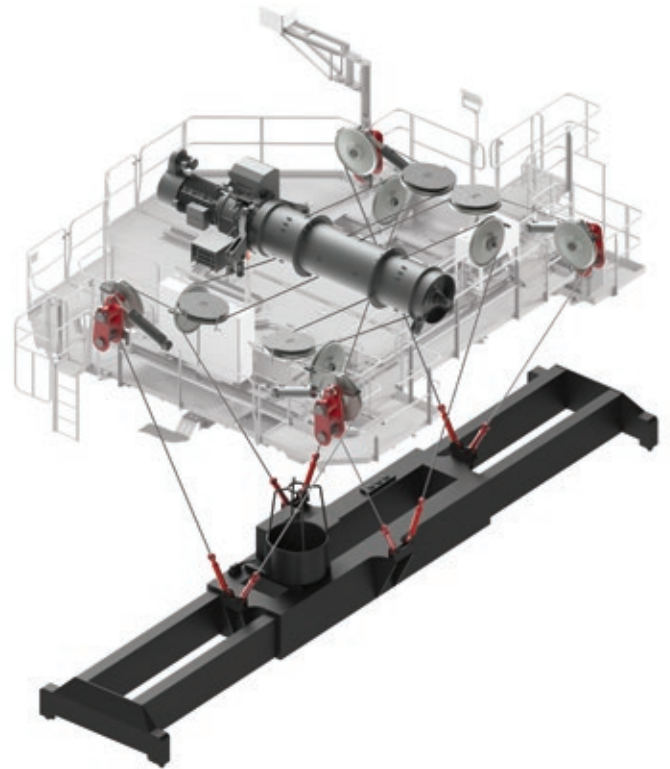

Advantages by Design

- Minimal spreader positioning times.
- No-sway in hoist, trolley and travel directions.
- Anti-skew.
- Trim and skew spreader positioning.
- No additional ropes or devices necessary.
- No head block - Reduced rope load and tare weight.
- Lower energy consumption.
- All electric spreader - Less maintenance.
- Significant increase in productivity when compared with alternative designs. Minimal spreader positioning times.

Gantry Travel System

Advantages by Design

- Direct driven - No chain drive
- Gantry travel with load
- Reduced tyre wear with differential axles allowing wheels to rotate during 90° turn.
- 4 Electric motors, 1 per corner



Liebherr Rubber Tyre Gantry Crane

- Liebherr reeving system: Sway prevention, not sway correction.
- Electric (gantry align) steering.
- Rigid robust structure - Optimum for automation. Optional DGPS auto steering and container positioning.
- Direct gearbox driven travel systems.
- Separate drives for hoist, travel and trolley, with no need for side shift on the spreader. Allows superior fine positioning with simultaneous motion.
- Worldwide Liebherr service network.
- Extensive training (in-house and on-site).
- Purpose built state-of-the-art design and production facilities located in Ireland since 1958.
- Highly skilled and experienced employees with expertise in-house for after sales service.
- Responsibility with Liebherr, eliminating interface and compatibility problems (i.e. structural, mechanical and electrical design, production, commissioning and service).

