T 264

www.liebherr.com

LIEBHERR

Mining Truck



Nominal payload: Up to 240 t / 265 ton
Gross Vehicle Weight (GVW): 416 t / 459 tons

Engine power:
2,013 kW
2,700 HP

Speed on grade at rated GVW:
Diesel 15.2 km/h / 9.4 mph
Trolley 24.2 km/h / 15 mph
*Effective grade 10%

Overview

T 264



Engine Power
2,013 kW / 2,700 HP



Gross Vehicle Weight
416 tonnes / 459 tons



Nominal Payload
240 tonnes / 265 tons



Unmatched cycle time

- Class-leading payload
- Perfect match with Liebherr excavators
- High speed on grade
- Fast dump cycle times

Experienced reliability

- Advanced hydraulic design and fast cycle times
- Solid state Liebherr Litronic Plus AC drive system
- Extended component lifetime

Perfect truck shovel match

Backhoe

- 4 pass loading of 600t class excavator
- 3 pass loading of 800t class excavator

Face shovel

- 4 pass loading of 600t class excavator
- 3 pass loading of 800t class excavator



User-centric design

- Enhanced driving comfort
- Safe work environment
- Ground level service access

Versatile for all applications

- Autonomous solutions
- High altitude kit
- Cold climate
- Sound attenuation kit

Sustainable Performance

- US EPA Tier IV engine option
- Complete Liebherr powertrain solution
- Trolley Assist System option

Performance & sustainability

Powertrain

+4%

More engine power





Liebherr D9812 engine

The Liebherr D9812 engine is highly responsive and reactive by design, providing superior performance and required horsepower for increased productivity. By utilizing in-house key components the D9812 delivers outstanding performance and fuel consumption.

2,013 kW / 2,700 HP at 1,800 RPM
12 cylinder V-engine
Displacement 62 l / 3,787 in³



Litronic Plus AC Drive System

Designed, developed and built by Liebherr, the Litronic Plus AC Drive system maximizes the electrical power conversion into mechanical torque, increasing the acceleration and minimizing energy consumption.

High performance

- Maximized electrical power conversion into mechanical torque
- Lower weight vs mechanical drive
- High speed on grade and higher rim pull forces

Electric drive vs mechanical drive

- Reduced maintenance costs and total oil consumption
- Reduced cost of additional cooling system for downhill loaded operations
- Reduced service time

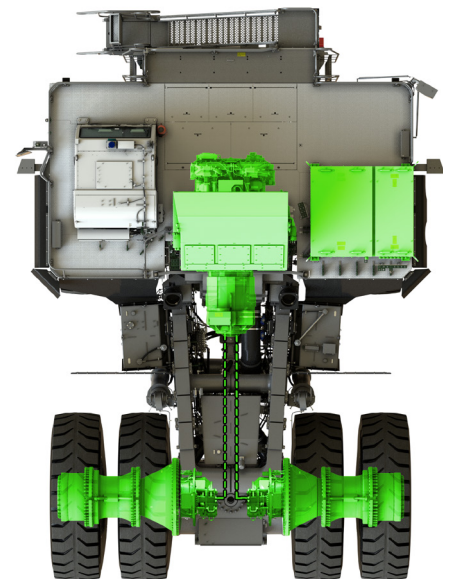

Complete Liebherr powertrain

With the integration of the Liebherr D98 engine series, Liebherr provides complete vertical integration of the powertrain for its large and ultra-class trucks.

Productivity

Hauling capacity

Class leading payload

The intelligent design of the T 264 allows to move more tonnes per hour by maximizing payload and minimizing cycle times. Pairing the 240 t / 265 ton Liebherr T 264 with the Liebherr R 9800 hydraulic excavator offers a versatile and productive mining fleet. The fast swing of the R 9800 and perfect bucket pass match to the T 264 will load it with three bucket passes providing quick loading times that lead to higher productivity.

Unmatched cycle times

The Liebherr T 264 is powered by the most powerful engine in its class at 2,013 kW / 2,700 HP along with the efficient Liebherr Litronic Plus AC Drive System. With the advanced hydraulic design and fast cycle times, the T 264 moves more material in less time. Designed with safety in mind, the T 264 is equipped with 3,300 kW/4,425 HP dynamic braking power to operate efficiently on downhill hauls.

High speed on grade

Speed on grade is a major contributor to fast cycle times. The Liebherr Litronic Plus AC Drive System improves cycle time efficiency by providing consistent uphill speed, differing from traditional mechanical drive trucks that require shifting of gears.





Perfect pass match with Liebherr excavators

R 9800



Backhoe
47.5 m³ / 62.1 yd³
3 passes



Face shovel
42 m³ / 54.9 yd³
3 passes

R 9600



Backhoe
37.5 m³ / 49.1 yd³
4 passes



Face shovel
37 m³ / 48.4 yd³
4 passes

R 9400



Backhoe
24 m³ / 31.4 yd³
6 passes



Face shovel
22 m³ / 28.8 yd³
6 passes



Comfort Operator environment



User-centric design

Liebherr is committed to designing mining trucks that operators want to drive. The ergonomic design of the T 264 cab creates a safe, comfortable, and productive environment for operators. The cab provides maximum visibility utilizing tinted safety glass windows, and is certified to protect against roll-over and falling-object incidents. The integrated HVAC system provides comfort in all temperature extremes.

Liebherr mining trucks are equipped with ladders and platforms that allow easy engine access. The ground level maintenance areas provide safe and efficient service access.



Cab features

- Spacious interior
- Large panoramic windshield
- Integrated color touchscreen
- Ergonomic layout
- Pressurized cab to prevent dust penetration



Active intelligent control systems

The Liebherr active intelligent control systems provide safety for the operator:

- Four wheel speed-sensing to optimize traction performance
- Slip/slide control to reduce torque on wheels which rotate faster and provide on-demand torque requirements
- Traction control in which torque is automatically adjusted to the rear wheels to maximize traction when cornering accelerating from a standstill, or traveling on wet or icy roads
- Anti-roll back operable in forward and reverse
- Operator adjustable dynamic braking speed limit control for downhill operations
- Configurable speed limits for loaded and unloaded states
- Configurable speed inhibitors for truck overload, reverse and dump body raise



Double A-arm suspension

- Keep optimal ground contact of the tire within the whole suspension stroke
- Reduce tread and wear with optimized camber and toe angle
- Improve operator ride quality and reduce overall body vibration exposure

Next generation mine automation

Get the best out of your Liebherr Mining truck fleet

Liebherr autonomous solutions deliver the next generation of onboard intelligence, with reduced dependency on site infrastructure and centralized supervisory systems. Together with vehicle-to-vehicle technologies, our smart autonomous solutions provide onboard obstacle avoidance and load area path planning capabilities for optimization of traffic flow.



Higher level of safety



More flexibility with seamless integration



Smart autonomous solutions



Liebherr autonomous solutions provide production advantages



Flexible scope of supply



Autonomy Ready kit

Machine designed and configured with drive-by-wire capability

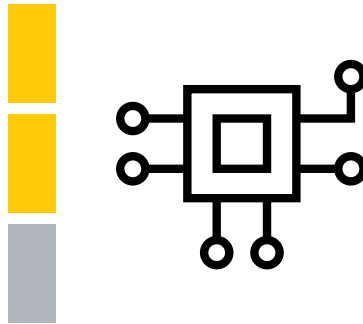

Autonomy kit

Autonomous Machine equipped with onboard perception and robotics - capable of integration via an "open protocol" to traffic management solutions

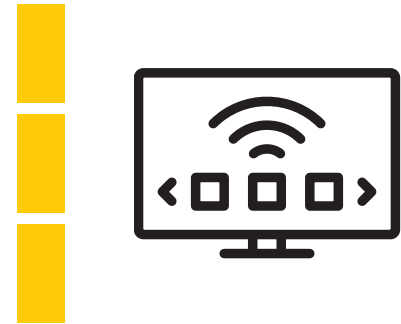

Complete solution

Complete autonomous haulage solution integrated with traffic and fleet management systems

Interoperability with other autonomous assets

In terms of Automation, Liebherr supports and promotes the development of an Open and Interoperable Mine Autonomy Platform that enables:

- Vendor agnostic control of mixed fleets of OEM robotic machines
- Use of multiple onboard autonomous solution options across multiple OEM models
- Trucks with different autonomous solutions working together supported by a single central control system via the use of standardized "Open Protocols"

Interoperable Mine Autonomy will provide customers the freedom to choose preferred combinations of equipment, onboard autonomous solutions and central control platforms.



Efficiency

Trolley Assist System



1.6x faster

Trolley vs Diesel speed on grade (10%)

29 - 54%

Less kt CO₂ emissions and fuel consumption*

*Based on 1-3 km / 0.6-1.9 mi trolley line (25 - 80% of entire cycle)

Low emissions solution

The Liebherr Trolley Assist System is an effective first step on the road to zero emission mine sites of the future. Utilizing an overhead pantograph to connect the electric-drive system to the electrical network. The Trolley Assist System offers:

- Increased truck fleet productivity, or reduction in fleet size while maintaining yearly production, versus standard trucks
- Reduction of fuel consumption from 37 l / 9.8 gal to 2.3 l / 0.6 gal of diesel for a 1 km / 0.6 mi trolley run
- Reduction of carbon footprint by decreasing the truck fleet CO₂ emissions

Zero emissions ready

Liebherr AC drive technology readily supports future Zero Emissions technologies. Our approach is aligned with the Liebherr Company values to be environmentally responsible by having a strong Zero Emission Strategy built on Liebherr embedded core competencies. Liebherr can offer today a solution to their mining customers to start their Zero Emission Journey.

Increased productivity

Liebherr has developed the Trolley system in which trucks are able to operate at higher speed on grade and reduce cycle times. By augmenting speed on grade up to 24.2 km / 15 mph, the Trolley Assist System maximizes productivity, offering higher production per hour.

Proven field experience

Liebherr delivers proven field experience with T 284 units fitted with the Trolley Assist System already in operation on different sites.

One-stop shop

Liebherr has developed strategic partnership agreements to support their customers with a complete solution.



Trolley Assist System

- Option for new truck units, all models
- Compatible and performance-enhancing in combination with diesel powertrain
- Supports zero emissions powertrain development

Agnostic approach on power supply and storage

- Diesel engine, batteries, hydrogen, ammonia, and methanol

Liebherr AC Drive System

- Maximize electrical power conversion into mechanical torque
- Deliver high speed on grade and higher rim pull forces

Protecting your most important assets

Safety



Operator safety

The T 264 is fitted with an ergonomic cab that creates a safe and comfortable environment for the operator. The cab provides maximum visibility utilizing tinted safety glass windows and is certified for roll-over and falling-object protection.



Safety in maintenance

The T 264 is equipped with ladders and platforms allowing easy engine access. The working heights of maintenance areas provide safe and efficient access.



Fire prevention features

Lower fire risk by:

- Routing piping and hosing away from hot areas and ignition points
- Encapsulating and insulating exhaust pipes as standard
- Insulating turbos and exhaust manifolds as standard



Stability and control

The innovative Traction Control System is designed and developed exclusively for Liebherr mining trucks. This advanced system improves steering and truck stability, extending tire life even in the most challenging conditions.



LED lighting system

The T 264 is easily visible at night or in extremely dusty working conditions thanks to the LED lights located throughout the truck.



Safety in operation

A safe work environment is critical for every mine site, thus the T 264 offers:

- Payload overload warnings
- Certified steering and braking accumulators
- Engine shutdown switches in cab and at ground level

Easy & safe operations
Maintenance



Ground level access

The T 264 has been designed for easier maintenance and quicker servicing. The central service station is located on the fuel tank and provides easy accessibility for maintenance as standard equipment. Refill and separate drain points of the T 264 are easily accessed from the ground with fast couplings and depressurized valves.



Filter and manifolds access

Central service station with quick disconnects

Service door on axle box for inspections



Lubrication system

- Test mode allows all injectors to be easily checked to verify they are working properly
- Automatic grease system allows sufficient lubrication of critical pivot points
- System controller offers programmable (5-30 min) lubrication of critical pivot points



Digital Services

- Connectivity enabled services utilize data generated on the machine to provide insights and recommendations required to drive fleet performance
- Enables the integration of Liebherr's technologies, engineering knowledge, and mining expertise with customer technology landscape



Easy and fast service

- Easy access to check brake component wear
- Service door on axle box for inspections
- Control box with multiple access doors and swing out modules

Long-lasting performances

Reliability

Vertical Integration

As an Original Equipment Manufacturer (OEM), Liebherr has built an industry reputation as strong as the high quality mining components and trucks that we develop and produce. The T 264 haul truck has a proven design with the integration of the robust and reliable mining-optimized components developed and manufactured by Liebherr, ensuring the highest reliability and best performance.

Mining Know-How

Liebherr mining trucks are conceptualized, designed and built for the mining industry. Our mining equipment and customer service are dedicated to our customers; their success is our success.

To meet customer and industry requirements, Liebherr engineers use specific 3D simulation solutions such as Finite Element and Fatigue Life Analysis.



Superior structure

- Durable, lightweight frame with class leading payload capability
- Designed according to international weld fatigue guidelines
- Fabricated according to American Welding Society standards
- Robotically welded
- Strategically located cast components and hollow box rails with fully welded internal stiffeners

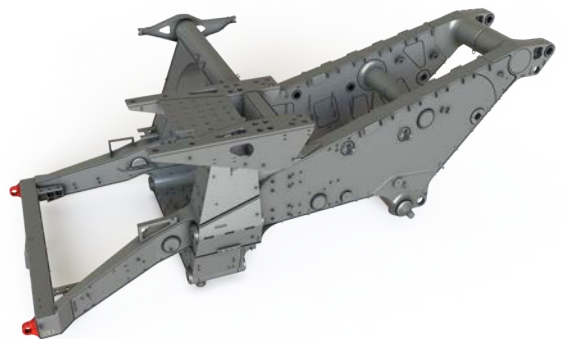

500,000

operating hours experience



Solid state AC drive system

- Liquid cooled for reduced footprint and maintaining optimum component temperatures
- Complete drive system designed and manufactured by Liebherr for use in the most demanding mining environments



Quality: the Liebherr Trademark

Providing reliable machines for customer mine sites is the highest priority for Liebherr Mining. The engineering expertise and commitment to continuous improvement combine to make Liebherr mining equipment industry-leading machines. The T 264 is a robust solution with proven design, with more than 500,000 operating hours.

Technical Data

Engine

Standard	
Model	Cummins QSK 60
Type	V configuration, 4-cycle, water-cooled
Aspiration	Single-stage turbocharged and aftercooled
Air cleaner	2 x dry-type, double element, pre-cleaner, automatic dust ejector, electronic restriction monitor
Lubrication system (method)	Pressurized by internal pump
Lubrication system (filtration)	centrifugal oil filtration
Tier rating	available in fuel-optimized (FO) and emission-optimized (EO) calibration
Engine speed	1,900 rpm
Gross power - ISO 3046-1	2,013 kW / 2,700 HP
Number of cylinders	16
Bore	159 mm / 6,25"
Stroke	190 mm / 7,48"
Displacement	60 l / 3,661 in ³
Starting	Electric

or

Option A	
Model	Liebherr D9812
Type	V configuration, 4-cycle, water-cooled
Aspiration	Single-stage turbocharged and aftercooled
Air cleaner	2 x dry-type, double element, pre-cleaner, automatic dust ejector, electronic restriction monitor
Lubrication system (method)	Pressurized by internal pump
Lubrication system (filtration)	Spin-on style filter canisters with centrifugal bypass filtering
Tier rating	Available in fuel-optimized (FO) calibration
Engine speed	1,800 rpm
Gross power - ISO 3046-1	2,013 kW / 2,700 HP
Number of cylinders	12
Bore	175 mm / 6.9"
Stroke	215 mm / 8.5"
Displacement	62 l / 3,787 in ³
Starting	Electric

or

Option B	
Model	MTU 16V4000 C23 (Tier IV C45)
Type	V configuration, 4-cycle, water-cooled
Aspiration	Single-stage turbocharged and aftercooled; Tier IV: Two-stage: turbocharged with exhaust gas recirculation (EGR)
Air cleaner	2 x dry type, double element, pre-cleaner, automatic dust ejector electronic restriction monitor
Lubrication system (method)	Pressurized by internal pump
Lubrication system (filtration)	centrifugal oil filtration
Tier rating	Available in fuel-optimized (FO) modes and emission optimized (EO); available Tier IV emission calibration (EGR)
Engine speed	1,800 rpm
Gross power - ISO 3046-1	2,013 kW/2,700 HP
Number of cylinders	16
Bore	170 mm / 6.7"
Stroke	210 mm / 8.3"
Displacement	76.3 l / 4,656 in ³
Starting	Electric

Consult factory for other engine options

Electric Drive System

Control system	Liebherr Litronic Plus AC drive system with IGBT technology
Control box	liquid cooled power components, pressurized cabinet
Traction control	Litronic Plus traction control system, computer controlled in propel and dynamic braking, forward and reverse, all-wheel speed sensing
Main alternator	AC brushless, direct drive, forced air cooling
Wheel motors	Litronic Plus AC induction motors, forced air cooling
Gear ratio	40:1
Max. travel speed	55 km/h / 34.2 mph
Cooling system	variable speed AC motor with twin impeller radial cooling fans
System voltage level	1,600 V AC / 2,000 V DC
Final drive type	Planetary

Braking Systems

Electric dynamic braking, forced air over quiet stainless steel grid resistors with dry disc service and secondary hydraulic braking system.	
Electric dynamic braking capacity	3,300 kW / 4,425 HP
Dynamic braking type	Electric
Dynamic braking speed control	operator-adjustable, automatically limits truck speed on downhill grade when set
Service brake type - front	inboard single disc, 5 x calipers per disc, wheel speed
Service brake type - rear	single disc per side, dual calipers per disc, armature speed
Parking brake type	spring-applied, pressure-released, 2 x calipers per rear disc
Adjustable speed limits	configurable speed limits for empty and loaded, adjustable for site requirements
Brake certification	ISO 3450:1996
Filtration cleanliness level	15/13/11 per ISO 4406:2021

Steering

Ackermann center point lever system, full hydraulic power steering with accumulator safety backup. Isolated from dump hydraulic system. Two double-acting hydraulic cylinders.	
Filtration cleanliness level	15/13/11 per ISO 4406:2021
Steering standards	ISO 5010:2007
Turning radius - tire centerline	15.7 m / 51'7" (ISO 5010:2007)
Vehicle clearance radius	16.5 m / 54'2" (ISO 5010:2007)
Steering angle, left or right	+/- 20°

Hoist System

Two double-stage, double-acting hoist cylinders with inter-stage and end cushioning in both directions. Electronic joystick with integrated engine high-idle switch and full modulating control in both extend and retract.	
Dump angle	49° (45° with optional kick-out switch)
Dump cycle time	34 sec.
Body raise time – high idle	21 sec.
Body power down – high idle	13 sec.
Remote dump	standard – quick disconnects for external power dumping accessible from ground level
Filtration cleanliness level	15/13/11 per ISO 4406:2021

Suspension System

System	
Front	Double A-arm with inclined king pin pivot, spindle, and nitrogen over oil suspensions with integral damping
Rear	three bar linkage comprised of triangular upper link plus two bottom drag links and nitrogen over oil suspensions with integral damping
Rear axle oscillation	9.5°

Tire / Rims

Tires*	50 / 80 R57 46 / 90 R57 1200 / 90 R57
Rims	29" x 57" bolt on rims 32" x 57" optional bolt on rims

* Consult factory for additional information

Frame

Closed box structure with multiple torque tube cross-members, internal stiffeners and integrated front bumper. Steel castings are used in high stress areas.	
Welding	frame rails welded inside and out with ultrasonic inspection aligned with AWS D1.1

Operator's Cab

Deluxe cab with integrated ROPS, FOPS, and double wall design for optimum insulation. Fully adjustable air suspension operator seat with double lumbar support and full-size second seat for training requirements. Operator comfort controls include a tilt steering wheel, heater, defroster and standard AC. Real-time vital truck information is clearly displayed to the operator and also recorded for download.	
Standards compliance	ISO 3449:2005 (Level III), ISO 3471:2008
HVAC capacity	8.4 kW

Weights

Nominal payload	240 t / 265 ton
Gross vehicle weight (GVW)	416 t / 459 ton
Empty vehicle weight (EVW)	176 t / 194 ton
Chassis weight ¹⁾	144 t / 259 ton
Body ²⁾	32 t / 35 ton
Front axle weight distribution	
Empty (%)	50%
Loaded (%)	33%
Rear axle weight distribution	
Empty (%)	50%
Loaded (%)	67%

¹⁾ Standard truck (less options), tires and rims, 100 % fluids (fuel tanks, hydraulic tank, gears, suspensions, crankcase, coolant, grease and charged accumulators)

²⁾ Actual dump body weight will vary based on customer application and supplier design

Fluid capacities

Fuel tank	2 x 1,559 l / 412 gal
Optional fuel tank	2 x 2,460 l / 650 gal
Hoist oil	
Tank	969 l / 256 gal
System	1,060 l / 280 gal
Cooling system	
Standard engine	775 l / 205 gal
Option A engine	901 l / 238 gal
Option B engine	886 l / 234 gal
Engine oil	
Standard engine	260 l / 68.7 gal
Option A engine	346 l / 91.4 gal
Option B engine	300 l / 79.3 gal
Rear wheel drive oil	2 x 175 l / 46.2 gal
Front wheel oil	2 x 52 l / 13.7 gal
Grease tank	55 kg / 120 lb

Body

Body sizes are custom designed to fit customer requirements and specific applications. Please contact factory for options.

Dimensions

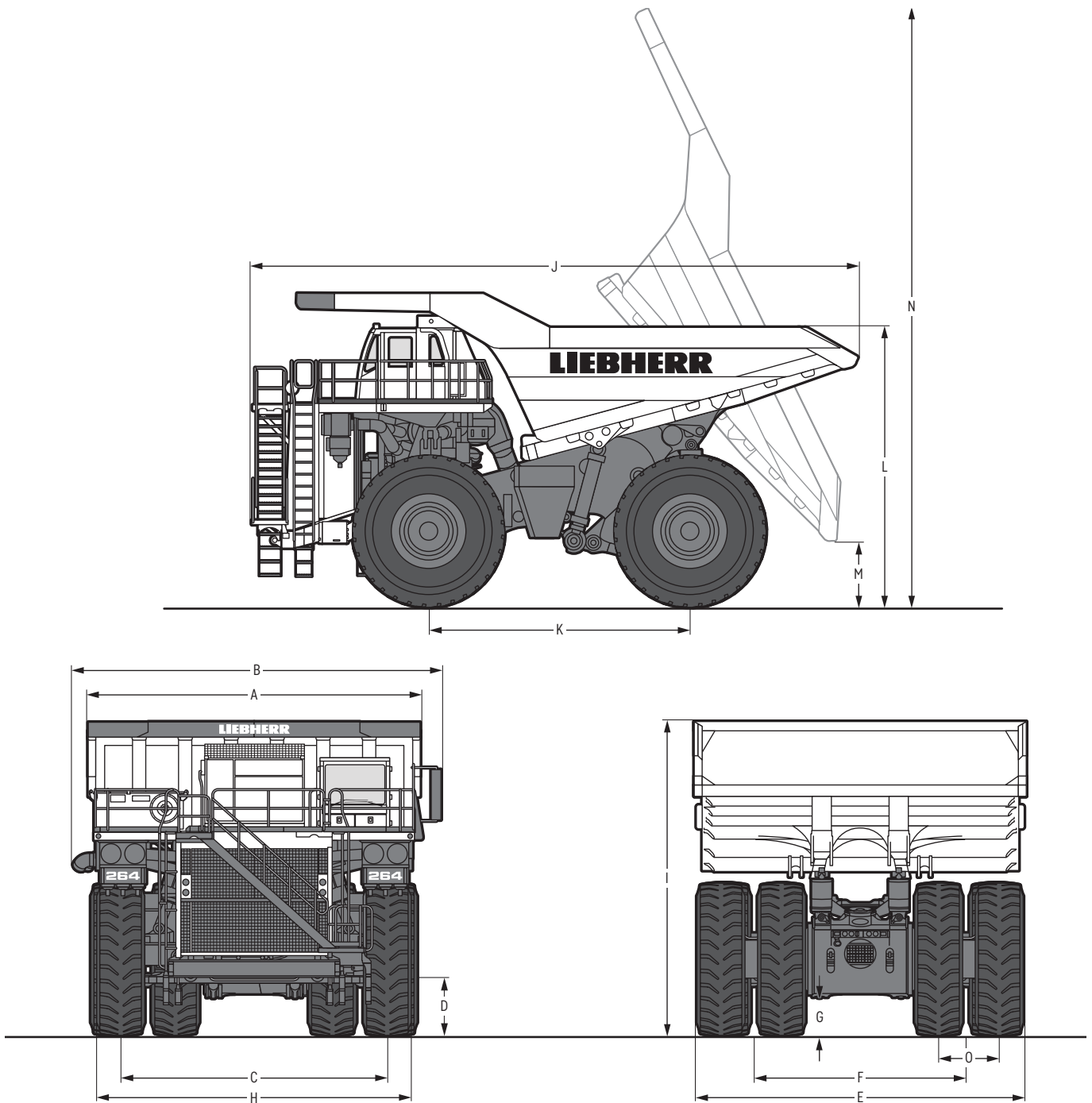

		mm / ft in
A	Overall canopy width*	7,841 / 25' 7"
B	Overall truck width (operating width)*	8,621 / 28' 3"
C	Front track width	6,411 / 21'
D	Bumper to ground clearance	1,149 / 3' 8"
E	Overall rear dual tire width	7,959 / 26' 1"
F	Rear track width	5,166 / 16' 11"
G	Rear axle clearance	675 / 2' 2"
H	Overall front tire width	7,569 / 24' 10"

		mm / ft in
I	Front canopy height*	7,171 / 23' 5"
J	Overall truck length*	14,197 / 46' 6"
K	Wheelbase	6,119 / 20' 1"
L	Loading height*	6,280 / 20' 6"
M	Dump clearance*	1,321 / 4' 3"
N	Overall height - body raised*	14,005 / 45' 10"
O	Dual spacing	1,420 / 4' 7"

*dump body specific

Performance Curves

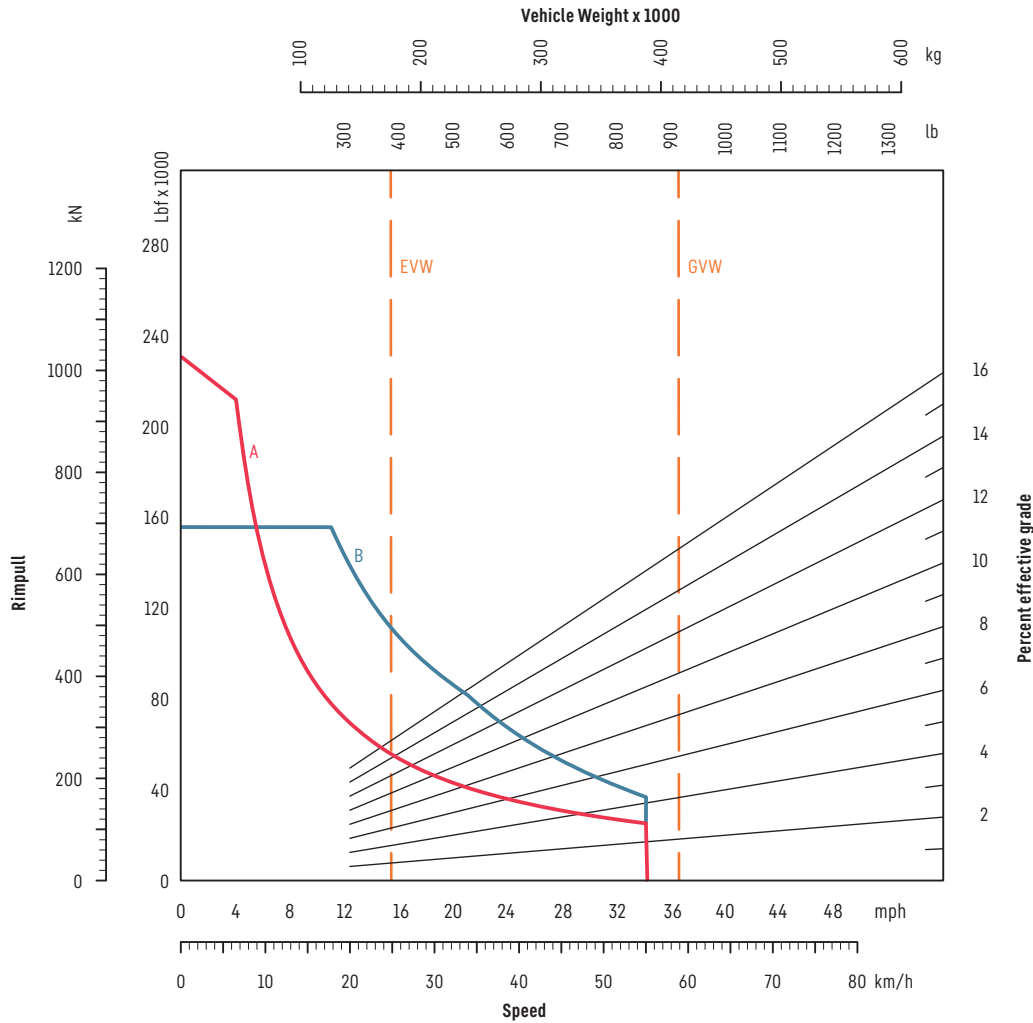

Performance Chart Parameters

Gross power	2,013 kW / 2,700 HP
Net power	1,964 kW / 2,634 HP
Tire size	50/80 R57
Gear ratio	40 to 1
Reference curves	(A): Propulsion 2,013 kW / 2,700 HP (B): Dynamic Braking

Note: The propulsion curve is calculated using net horsepower, therefore site specific and climatic variables will have an effect on the parasitic loss estimations.

Truck Match

Liebherr excavator and configuration	R 9400 BH	R 9400 FS	R 9600 BH	R 9600 FS	R 9800 BH	R 9800 FS
Standard bucket*	m ³ 24	m ³ 22	m ³ 37.5	m ³ 37	m ³ 47.5	m ³ 42
	yd ³ 31.4	yd ³ 28.8	yd ³ 49.1	yd ³ 48.4	yd ³ 62.1	yd ³ 54.9
Number of passes	Standard / Optional 6	Standard / Optional 6	Standard / Optional 4	Standard / Optional 4	Standard / Optional 3	Standard / Optional 3

* for 1.8 t/m³ material density

Loading Charts

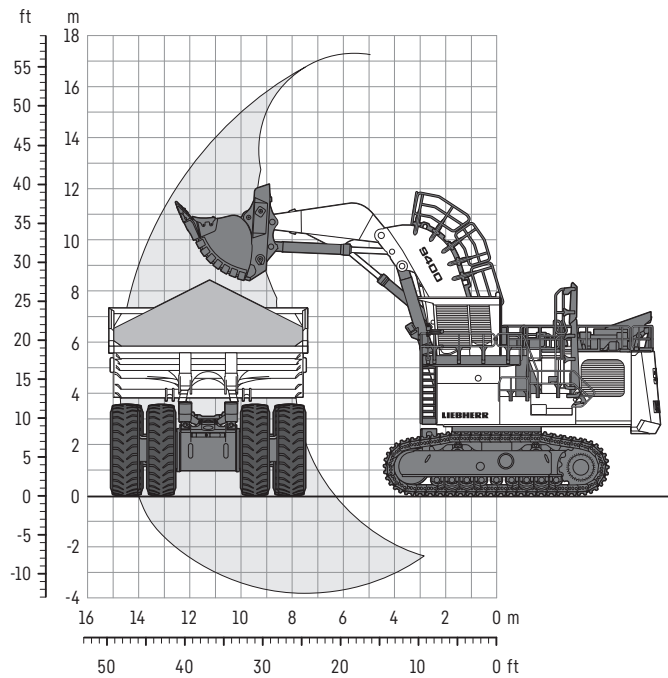

T 264 Mining Truck

loaded by the Liebherr R 9400 hydraulic excavator in face shovel configuration

Maximum dump height	11.2 m / 36' 8"
Truck loading height	6.3 m / 20' 6"
Passes to fill (given 1.8 t/m ³ material density)	6 passes

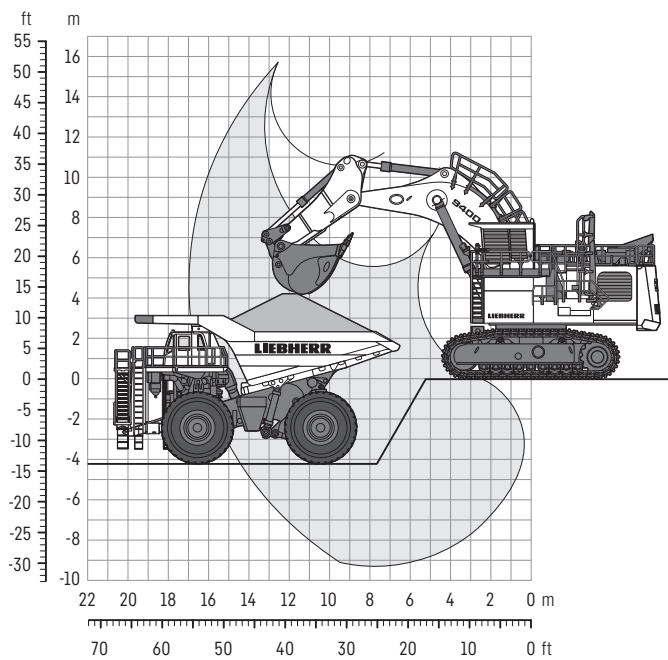

T 264 Mining Truck

loaded by the Liebherr R 9400 hydraulic excavator in backhoe configuration

Maximum dump height	10.6 m / 34' 8"
Truck loading height	6.3 m / 22' 6"
Passes to fill (given 1.8 t/m ³ material density)	6 passes

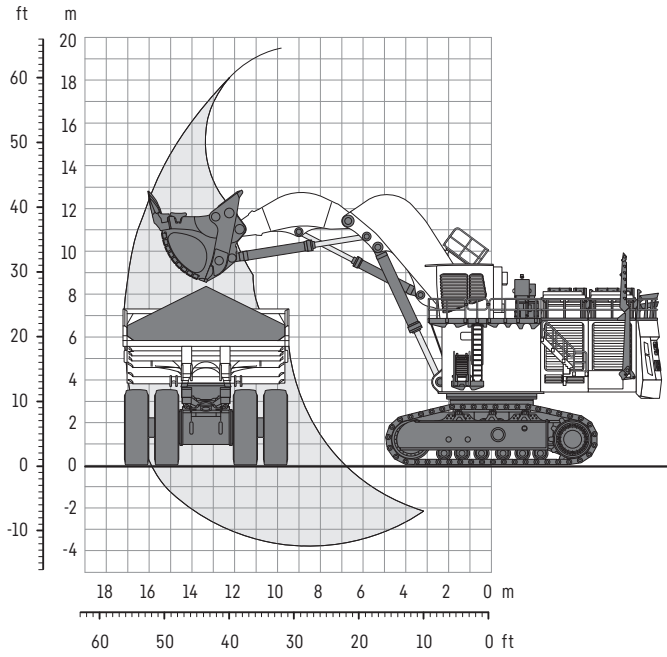

T 264 Mining Truck

loaded by the Liebherr R 9600 hydraulic excavator in face shovel configuration

Maximum dump height	12.4 m / 42' 8"
Truck loading height	6.3 m / 20' 6"
Passes to fill (given 1.8 t/m ³ material density)	4 passes

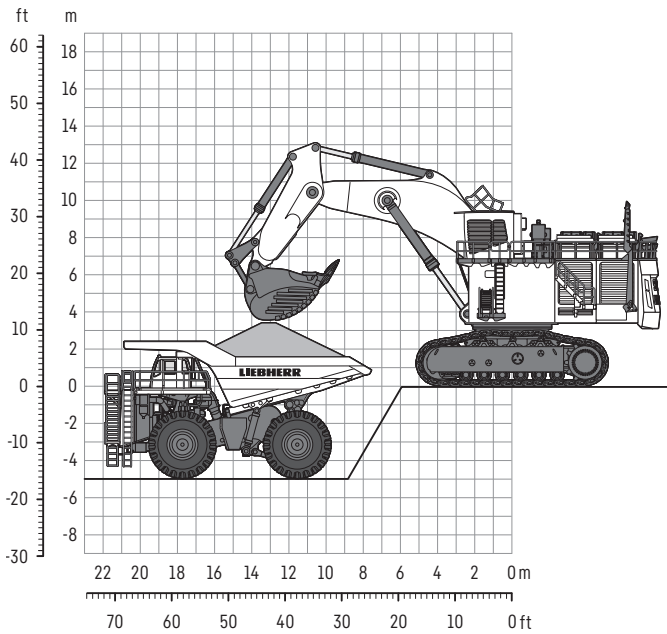

T 264 Mining Truck

loaded by the Liebherr R 9600 hydraulic excavator in backhoe configuration

Maximum dump height	10.6 m / 34' 9"
Truck loading height	6.3 m / 20' 6"
Passes to fill (given 1.8 t/m ³ material density)	4 passes

Loading Charts

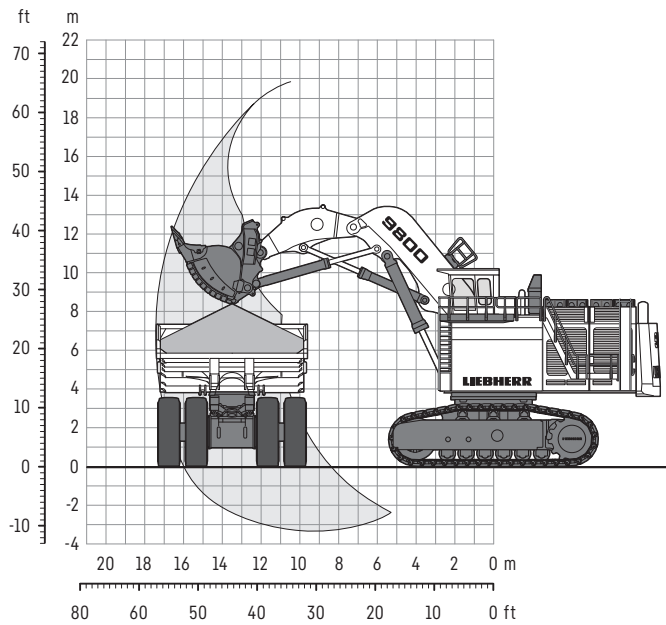

T 264 Mining Truck

loaded by the Liebherr R 9800 hydraulic excavator in face shovel configuration

Maximum dump height	12.4 m / 40' 7"
Truck loading height	6.3 m / 20' 6"
Passes to fill (given 1.8 t/m ³ material density)	3 passes

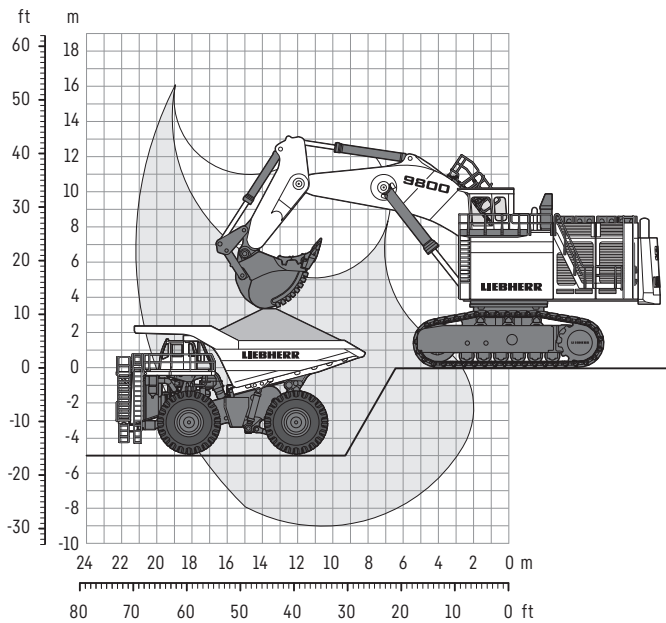

T 264 Mining Truck

loaded by the Liebherr R 9800 hydraulic excavator in backhoe configuration

Maximum dump height	10.9 m / 35' 9"
Truck loading height	6.3 m / 20' 6"
Passes to fill (given 1.8 t/m ³ material density)	3 passes

Standard Equipment

General

Access – 45° diagonal stair (driver's side access) with two side ladders with flexible steps

Accumulators – certified – steering (1 x 88 l/ 23.2 gal), front brakes (1 x 27 l/ 7.1 gal and 1 x 4 l/ 1 gal), rear brakes (1 x 7.6 l/ 2 gal and 1 x 4 l/ 1 gal)

Axle box – dual entry service access, rear air exhaust

Centralized service station – ground level, driver's side, with non-pressurized high flow fueling system

Color – white / gray

Fall protection – multiple personnel harness anchor points

Fluid sampling – multi sampling ports close to components

Grease system – automatic lubrication system

Heat exchangers – 1 x hoist system, 2 x final drive gear oil

Hydraulic circulation loop filter

Hydraulic filters – high pressure and return line brake, steering and hoist w/ electronic monitoring

Jacking points – labeled

LED payload display – 2 x superstructure mounted

Liebherr Mining Data (LMD)*

Mud guards – front and rear of fuel tanks, superstructure and battery control box

Park brake – spring applied pressure release

Recovery system – auxiliary connectors for brake, steering and hoist "buddy system"

Reverse alarm

Rock ejectors – bar type

Service access ladders – right and left engine bay ladders w/ rubber flexible steps

Shut off valves – suction and return line w/ electronic monitoring

Sight gauges – hydraulic tank, radiator, control box and front wheel hub

Towing points – front and rear, labeled

* Subscription fee required

Engine

Air cleaner dust ejectors – automatic

Air cleaners – two units with 2 elements per unit with electronic restriction monitoring in cab

Exhaust – side-mounted mufflers with insulated exhaust pipes

Fan clutch – variable speed, temperature controlled

Fuel/ water separator

Oil centrifuge filter

Prelube – pre-start engine oil pressurization to reduce dry engine turnover

Primary and secondary fuel filters

Radiator – L & M (Mesabi) flexible core with center-mounted level gauge on front face of surge tank

Roll out power module – engine, main alternator and hydraulic pump directly mounts to frame using removable tool system

Starter – electric

24 V Electrical

Batteries – 6 x 12 Volt, (3 banks of 2), 1,425 CCA each at -18 °C (0 °F), 1,755 CA at 0 °C (32 °F)

Battery box lockouts – ground level, battery (2 pole), propel and starter (single pole)

Electrical system – 24 VDC with circuit breaker protection

Engine stops – in-cab and ground level

AC Drive System and Controls

Anti roll-back – in forward and reverse

Brakes – dynamic braking w/ automatic hydraulic brake blending and hydraulic service brakes

Gear ratio – 40:1

Grid box – resistor grid control system and variable AC grid box blower motor

Litronic Plus control box – IGBT technology, liquid cooled, pressurized, filtered air inlet, ground fault warning and detection

Rear wheel drive – Liebherr gears and wheel motors

Traction control system with four-wheel speed sensing

Lighting

Access lights – 3 ladder, 1 superstructure

Brake warning lights (cab mounted external) – forward facing dynamic brake and service brake (LED)

Headlights – 4 x high beam, 4 x low beam (LED)

Reverse lights – 2 x axle box, 1 x driver's side superstructure (LED)

Service lights – 2 x engine bay, 2 x axle box (LED)

Truck lights – marker / clearance, tail, brake, dynamic brake and turn indicators (LED)

Operator Environment

Climate control – combined heater and air conditioner w/ multiple air ducts and filtered air

Cup holder – 2 center console mounted

Diagnostics interface – CANopen, Ethernet

Display screen – dimmable color touch screen w/ operator information and warning

Dual 5V USB charging ports

Dual overhead LED dome lights that illuminate when the door is opened

Integrated ROPS (ISO 3471:2008) and FOPS (ISO 3449:2005, Level II)

Mirrors – drivers side (flat), offside (convex) and access ladder (convex)

Power outlets – 12 VDC and 115 VAC

Power windows – driver and passenger

Pressurized cab – with fan on

Radio ready – wiring, speakers and DIN fitting

Seat belt – high visibility orange, 3 point, 50 mm wide

Seats – fully adjustable driver and passenger heated seats with air suspension

Speedometer – km/h / mph

Steering wheel – tilting and telescopic with horn and wiper control

Storage shelves and storage compartment located behind seats

Sun visors – 2 windshield sun visors and 1 driver's door pull down blind

Windows – tempered and tinted glass 6.3 mm

Windshield – laminated safety glass and tinted 9.5 mm

Wipers – two speed electric and intermittent with self park and dual wiper arms

Optional Equipment

General

Access stair – powered retractable stair to main diagonal stairway
Automatic fire suppression system
Color – Liebherr yellow / gray
Dump body options – liners, tailgates, rock deflectors, 45° limit kick out switch
Engine "roll over" protection switch
Multiple language decals
Rear view camera
Rims – double gutter
Undercarriage protection – front belly pan, fuel tank skid plates
Handheld fire extinguishers (2)

Operator's cab

Centered dashboard gauge panel in metric or imperial
Radio AM/FM/CD/USB/MP3/Bluetooth

Specific Solutions

Arctic package – diesel type engine coolant heater, heated mirrors, heated dump body exhaust, diesel fuel heater
Autonomy platform
High altitude package
Manual fuel fill tank w/ ladder platform
Trolley assist system

Lighting

Berm cornering lights (LED) – forward facing, superstructure mounted (DS and ODS)
Fog lights (LED) – 4 x bumper mounted
Grill illumination light (LED)
Hill cresting lights (LED) – 2 x top grill mounted
Overspeed light – externally mounted blue light on the top of cab
Park brake on/truck in neutral warning light (LED) – externally mounted on top of cab
Reverse light (LED) – off driver's side superstructure
Truck ID light (blue LED) – diagonal staircase mounted

WARNING

This product can expose you to chemicals including lead and lead compounds, which are known to the State of California to cause cancer and birth defects or other reproductive harm.
For more information go to www.P65warnings.ca.gov.

WARNING

Breathing diesel engine exhaust exposes you to chemicals known to the State of California to cause cancer and birth defects or other reproductive harm.

- Always start and operate the engine in a well-ventilated area.
- If in an enclosed area, vent the exhaust to the outside.
- Do not modify or tamper with exhaust system.
- Do not idle the engine except as necessary.

For more information go to www.P65warnings.ca.gov/diesel.

Subject to technical modifications. All comparisons and claims of performance are made with respect to the prior Liebherr model unless specifically stated.

Liebherr Mining Equipment Newport News Co. • 4100 Chestnut Avenue, Newport News, VA • USA-23607
Phone: +1 (757) 245 5251 • www.liebherr.com • E-Mail: info.lme@liebherr.com • www.facebook.com/LiebherrMining